

FuelTech

FT SPARK
GEN3 MAX2000



QUICK INSTALL GUIDE

GUIA RÁPIDO DE INSTALAÇÃO
GUÍA DE INSTALACIÓN RÁPIDA



IGNITION

1. Index

2. Presentation	3
3. Warranty terms	3
4. Characteristics	4
5. Installation	5
5.1 Mounting.....	5
5.2 Power supply	5
5.3 Harness connections table.....	5
5.4 Connection diagrams.....	10
5.5 Wiring harness installation	17
5.6 Wiring harness positioning	17
5.7 Ground reinforcement.....	17
5.8 Coils	17
5.9 Spark plug wires.....	18
5.10 Spark plugs.....	18
6. FTSPARK control	18
6.1 Individual triggering	18
6.2 Serial bus triggering	18
6.3 Input signal trigger edge.....	19
6.4 CAN network.....	19
6.5 Energy level selection	19
6.6 Wasted spark operation	22
6.7 Safety Features	23
6.8 Ignition delay time	23
7. Recalibrating ignition and fuel map.....	24
8. LED operation indicator.....	24
9. FTSPARK settings and operation.....	25
9.1 FTSPARK settings in FTManager software	25
9.2 FTSPARK settings in FuelTech Vision software	26
9.3 Spark duration (Multispark mode)	27
9.4 Setup on engines with sequential ignition.....	28
9.5 Datalogger channels.....	29
9.6 Status Events Information.....	30
10. FTSCAN 2.0 protocol.....	30
10.1 Physical layer	31
10.2 Operation	31
10.3 Setting the Energy Level via CAN	31
10.4 Setting the Spark Duration	31
10.5 Transmitted Diagnostic Channels.....	32
10.6 MeasureIDs.....	33
11. Dimensions	35

2. Presentation

The FTSPARK GEN3 MAX2000 represents the ultimate evolution of FuelTech's capacitive discharge ignition systems, delivering up to 2000 mJ per channel, with significantly higher spark current and duration—especially when operating in Multispark mode. Its new architecture ensures up to 83% efficiency and high output voltage even at reduced energy levels, enabling stable ignition of extremely rich mixtures, making it ideal for engines with high boost pressure, high compression ratios, running on alcohol or nitromethane. Additionally, by using the new Multispark mode, it is capable of operating with lean mixtures while delivering performance equal to or superior to that of inductive ignition systems.

Supporting 4, 6, or 8 independent channels, the FTSPARK GEN3 MAX2000 features advanced per-channel diagnostics via CANBUS, enhanced integration capability with any motorsport ECU, and the ability to operate using a single-wire multiplexed input, freeing up outputs on the FuelTech VCU. The FTSPARK GEN3 MAX2000 sets a new benchmark in reliability, ignition energy, and integration capability, positioning itself as the definitive solution for high-performance racing engines.

FTSPARK GEN3 Differentials:

- Up to 2000 mJ of energy per channel, high output voltage at any energy level, and increased spark current and duration;
- Programmable energy via CAN or through a dedicated energy level adjustment input;
- Advanced diagnostics with individual channel monitoring via CANBUS, simplifying fault detection and engine calibration;
- Compatible with engines up to 8 cylinders or rotary engines with up to 4 rotors;
- Single-wire serial bus, allowing the use of only one ECU output to trigger all ignition outputs;
- Enhanced mechanical robustness against vibration, impact, and G-forces — suitable for drag racing, rally, off-road, and endurance applications;
- 475-500V primary coil voltage, helping to prevent misfires;
- 175 A primary coil current when used with the FuelTech Racing CDI coil designed for FTSPARK;
- CAN communication with the FuelTech lineup for device diagnostics and channel logging in the datalogger;
- High-robustness automotive-grade connector;
- Maintains the same pinout and mounting points as the FTSPARK GEN2, allowing direct replacement;
- Die-cast aluminum enclosure IP67
- Enhanced thermal design, with greater heat dissipation capacity and improved heat exchange with the environment, resulting in a product that operates at lower temperatures and supports extended duty cycles.

3. Warranty terms

The use of this equipment implies total accordance with the terms described in this manual and exempts the manufacturer from any responsibility regarding product misuse.

This product must be installed and tuned by specialized auto shops or professionals with experience on engine tuning.

Ignoring any of the warnings or precautions described in this manual can cause engine damage and lead to warranty void of this product warranty.

Before starting any electrical installation, disconnect the battery.

This product is not certified for aeronautic purposes or any flying vehicles, as it has not been designed for such applications.

In some countries where an annual inspection of vehicles is enforced, no modification in the OEM ECU is permitted. Be informed about local laws and regulations prior to the product installation.

Important warning for proper installation of this product:

Always remove and insulate unused wires. NEVER roll up excess wiring as this may create an antenna that captures electromagnetic interference that may cause product malfunction.

Limited Warranty

This product warranty is limited to one year from the purchase date, only covering manufacturing defects and requiring purchase invoice presentation. Damages caused by misuse of the unit are not covered by the warranty. Warranty void analysis is done exclusively by FuelTech technical support team.

Manual Version 2.0 – March/2026

4. Characteristics

- Dimensions: 5.63 x 7.37 x 2.10 in
- Weight: 46oz
- Body: Die-cast aluminum and plastic
- Maximum operating temperature: 212 °F (derating starting at 176 °F)
- Voltage supply required for full power: 14-30V. Minimum voltage during cranking 8V
- Maximum operating frequency: 670Hz

Specifications	
Minimum energy	150mJ
Maximum Energy	2000mJ
Primary coil current	175A
Spark duration	330uS - 1500uS

Maximum Current Consumption

FTSPARK-4 (4 Coils)	24A @ 10000RPM
FTSPARK-6 (6 Coils)	36A @ 10000RPM
FTSPARK-8 (8 Coils)	48A @ 10000RPM

The module automatically limits the input current to 50 A, reducing the energy when the battery voltage is insufficient to achieve the desired energy level.

Wiring Harness

FTSPARK-4 (4 Coils):	23 Wires
FTSPARK-6 (6 Coils):	29 Wires
FTSPARK-8 (8 Coils):	35 Wires

Wire harness length: 59 in. at power outputs connected to coils and 118 in. at the other cables.

Maximum piston engine speed (with 16V battery)

Cylinders	Sequential	Wasted spark / 2 Stroke
4	22.500 RPM	11.250 RPM
5	15.000 RPM	NOT COMPATIBLE
6	15.000 RPM	NOT COMPATIBLE
8	11.250 RPM	NOT COMPATIBLE

Maximum rotary engine speed (with 16V battery)

Rotors	Rotary	Units
2	11.250 RPM	1 x FTSPARK-4
3	15.000 RPM	2 x FTSPARK-4
4	11.250 RPM	2 x FTSPARK-4

5. Installation

Capacitive ignition systems require special installation care for correct operation. The vehicle's electrical system suffers high current and voltage demand from the FTSPARK ignition system. It is essential to follow the installation instructions in this manual.



NOTE

If the log shows an energy drop caused by a decrease in battery voltage, the electrical installation must be inspected. In cases where the battery is installed far from the FTSPARK, it is necessary to use a larger wire gauge. A good solution is to make a secondary power terminal from the battery, using 2 AWG cable.



NOTE

The shield of the shielded cables must be grounded on only one end, preferably the one closest to the coil.

5.1 Mounting

Mounting must be done using the rubber mounts. Always use the 4 mounting points available on the FTSPARK body. **The FTSPARK must be installed as far away from heating sources as possible (such as turbochargers and exhaust manifolds) because it generates a lot of heat by itself. If installed on the engine bay, it must be mounted where air flows best.**

5.2 Power supply

NEVER invert the FTSPARK power connections. It has limited protection against battery polarity reversal, which may not be effective with certain types of coils, as they may provide a path for current to flow. The FTSPARK power supply, as well as all other electric loads of the car, must pass through the master switch for safety reasons and the master switch must NEVER interrupt the battery ground, always the hot terminal.



IMPORTANT

Always connect the power supply harness directly to the battery with a 60A fuse for each FTSPARK BOX. Do not use the chassis or engine block to ground the FTSPARK. Use the negative battery terminal.

To turn the FTSPARK on and off use a 12V switch connected to the analog input on pin #12. Do not connect the FTSPARK to voltage boosters. It generates current peaks exceeding 150A, which may damage the boosters and/or cause ignition malfunction. Do not use FTSPARK on systems with power supply voltage over 30V.

5.3 Harness connections table

Pin	Wire	Label	Function
1	Orange	COIL A (+)	Coil primary output. High voltage (Positive side)
2	Orange	COIL B (+)	
3	Orange	COIL C (+)	
4	Orange	COIL D (+)	
5	Orange	COIL E (+)	
6	Orange	COIL F (+)	
7	Orange	COIL G (+)	
8	Orange	COIL H (+)	

Pin	Wire	Label	Function
9	Yellow	Energy level	Energy level selection; (ground trigger) NOTE: If the FTSPARK is connected via the CAN network, it is not necessary to use this wire.
10	Yellow/Blue	--	Wiring harness CANBUS CAN LOW
11	Yellow/White	--	Wiring harness CANBUS CAN HI
12	Red	Switched 12V	FTSPARK Switch ON/OFF
13	Black	COIL A (-)	Coil primary output. Wire 750V. Twisted. (Power ground side) NOTE: Do not connect the shield to the negative of the coil.
14	Black	COIL B (-)	
15	Black	COIL C (-)	
16	Black	COIL D (-)	
17	Black	COIL E (-)	
18	Black	COIL F (-)	
19	Black	COIL G (-)	
20	Black	COIL H (-)	
21	Black	-BAT	Power ground. Connect to battery
22	Black	-BAT	
23	Black	-BAT	
24	Gray	Ignition Input A	Ignition trigger input A or Serial bus (1 wire)
25	Gray	Ignition Input B	Ignition trigger input B
26	Gray	Ignition Input C	Ignition trigger input C
27	Gray	Ignition Input D	Ignition trigger input D
28	Gray	Ignition Input E	Ignition trigger input E
29	Gray	Ignition Input F	Ignition trigger input F
30	Gray	Ignition Input G	Ignition trigger input G
31	Gray	Ignition Input H	Ignition trigger input H
32	Black	GND	Battery ground. Trigger signal reference
33	Red	+BAT	Power supply for FTSPARK. Connect to battery positive or main switch when required.
34	Red	+BAT	
35	Red	+BAT	

IMPORTANT

- Although the GEN2 harness is fully compatible with the GEN3, the use of the GEN3 harness is recommended, as it uses cables with higher current-carrying capacity.
- In the following electrical schematics, the power supply and grounding cables are represented in a braided form.

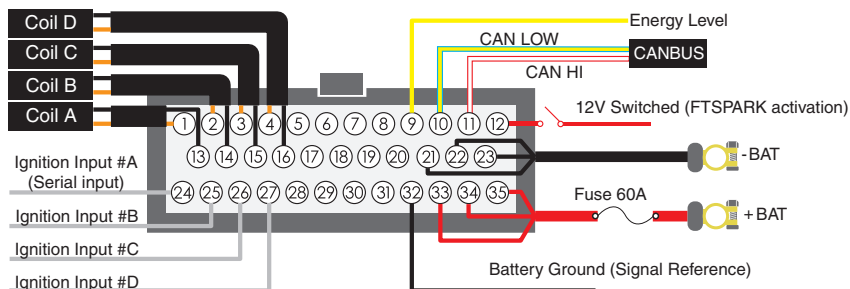

FTSPARK-4 Connector Diagram

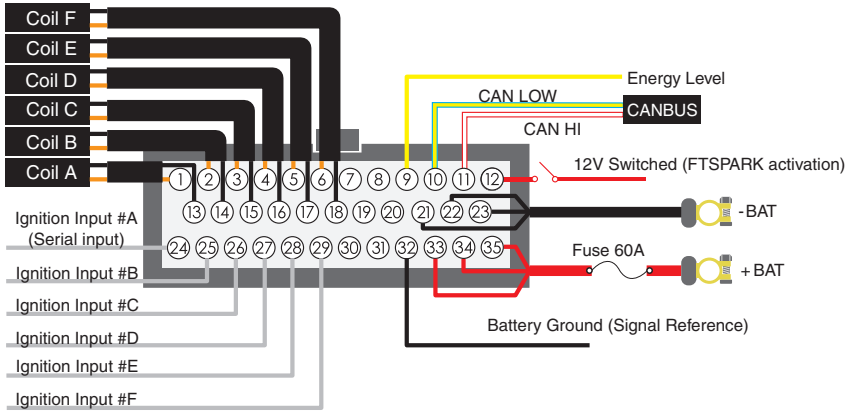

FTSPARK-6 Connector Diagram

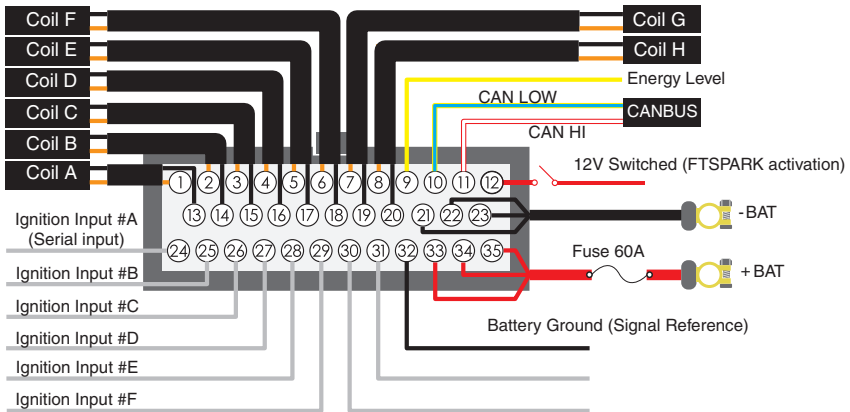

FTSPARK-8 Connector Diagram

Connection Table for 2 Modules – 8 Cylinders (Module A)

Pin	Wire	Label	Function
1	Orange	COIL A (+)	Coil primary output. High voltage (Positive side)
2	Not Used	-	
3	Not Used	-	
4	Orange	COIL D (+)	
5	Not Used	-	
6	Orange	COIL F (+)	
7	Orange	COIL G (+)	
8	Not Used	-	
9	Yellow	Energy level	Energy level selection; (ground trigger) NOTE: If the FTSPARK is connected via the CAN network, it is not necessary to use this wire.

10	Yellow/Blue	-	Wiring harness CANBUS CAN LOW
11	Yellow/White	-	Wiring harness CANBUS CAN HI
12	Red	Switched 12V	FTSPARK Switch ON/OFF
13	Black	COIL A (-)	Coil primary output. 750V wire. Twisted. (Power ground side) NOTE: Do not connect the shield to the negative of the coil.
14	Not Used	-	
15	Not Used	-	
16	Black	COIL D (-)	
17	Not Used	-	
18	Black	COIL F (-)	
19	Black	COIL G (-)	
20	Not Used	-	
21	Black	-BAT	Power ground. Connect to battery
22	Black	-BAT	
23	Black	-BAT	
24	Gray	Ignition Input A	Ignition trigger input A or Serial bus (1 wire)
25	Not Used	-	Not Used
26	Not Used	-	Not Used
27	Gray	Ignition Input D	Ignition trigger input D
28	Not Used	-	Not Used
29	Gray	Ignition Input F	Ignition trigger input F
30	Gray	Ignition Input G	Ignition trigger input G
31	Not Used	-	Not Used
32	Black	GND	Battery ground. Trigger signal reference
33	Red	+BAT	Power supply for FTSPARK. Connect to battery positive or main switch when required.
34	Red	+BAT	
35	Red	+BAT	

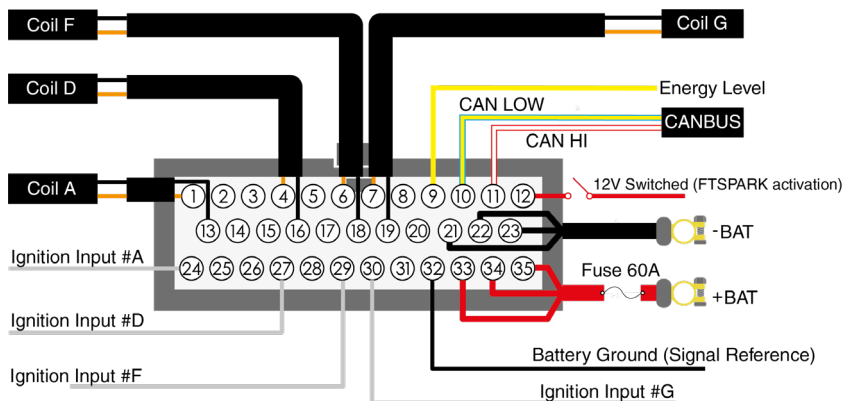

FTSPARK Module A

Connection Table for 2 Modules – 8 Cylinders (Module B)

Pin	Wire	Label	Function
1	Not Used	-	Coil primary output. High voltage (Positive side)
2	Orange	COIL B (+)	
3	Orange	COIL C (+)	
4	Not Used	-	
5	Orange	COIL E (+)	
6	Not Used	-	
7	Not Used	-	
8	Orange	COIL H (+)	
9	Yellow	Energy level	Energy level selection; (ground trigger) NOTE: If the FTSPARK is connected via the CAN network, it is not necessary to use this wire.
10	Yellow/Blue	-	Wiring harness CANBUS CAN LOW
11	Yellow/White	-	Wiring harness CANBUS CAN HI
12	Red	Switched 12V	FTSPARK Switch ON/OFF
13	Not Used	-	
14	Black	COIL B (-)	Coil primary output. 750V wire. Twisted. (Power ground side) NOTE: Do not connect the shield to the negative of the coil.
15	Black	COIL C (-)	
16	Not Used	-	
17	Black	COIL E (-)	
18	Not Used	-	
19	Not Used	-	
20	Black	COIL H (-)	
21	Black	-BAT	Power ground. Connect to battery
22	Black	-BAT	
23	Black	-BAT	
24	Gray	Ignition Input A	Ignition trigger input A or Serial bus (1 wire)
25	Gray	Ignition Input B	Ignition trigger input B
26	Gray	Ignition Input C	Ignition trigger input C
27	Not Used	-	
28	Gray	Ignition Input E	Ignition trigger input E
29	Not Used	-	
30	Not Used	-	
31	Gray	Ignition Input H	Ignition trigger input H
32	Black	GND	Battery ground. Trigger signal reference
33	Red	+BAT	Power supply for FTSPARK. Connect on battery positive or when main switch required.
34	Red	+BAT	
35	Red	+BAT	

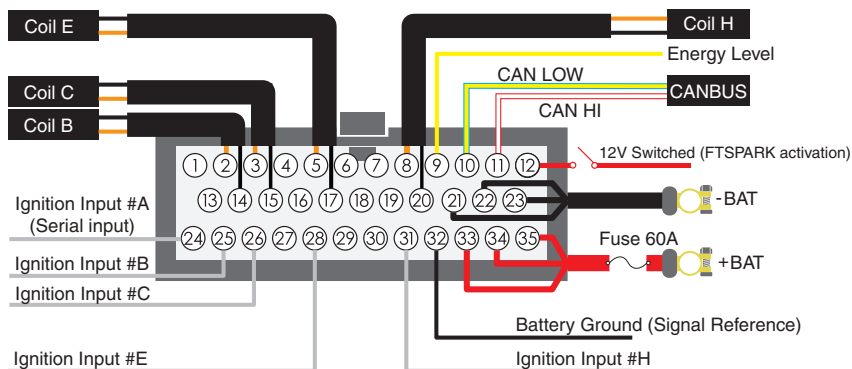

FTSPARK Module B

5.4 Connection diagrams

Individual Racing Coil CDI FuelTech

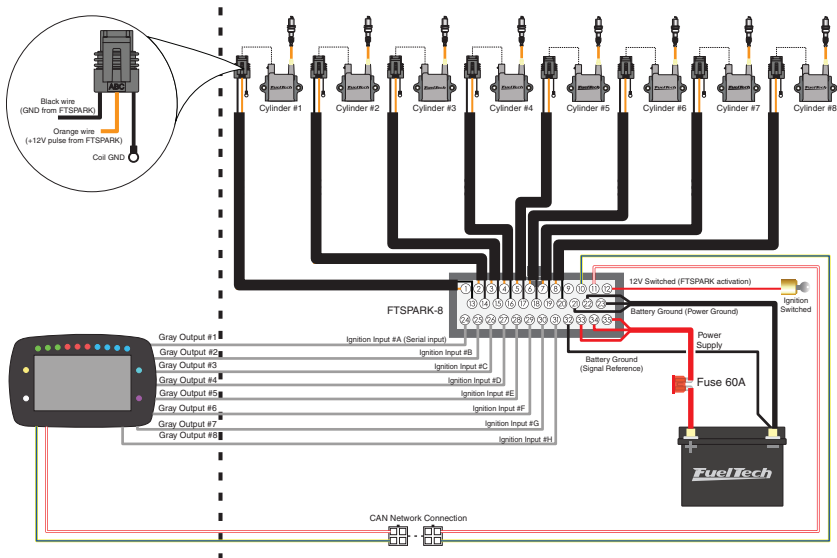

4 Cylinder with Serial bus (Single wire - only PowerFT ECU's and VisionFT ECU's)

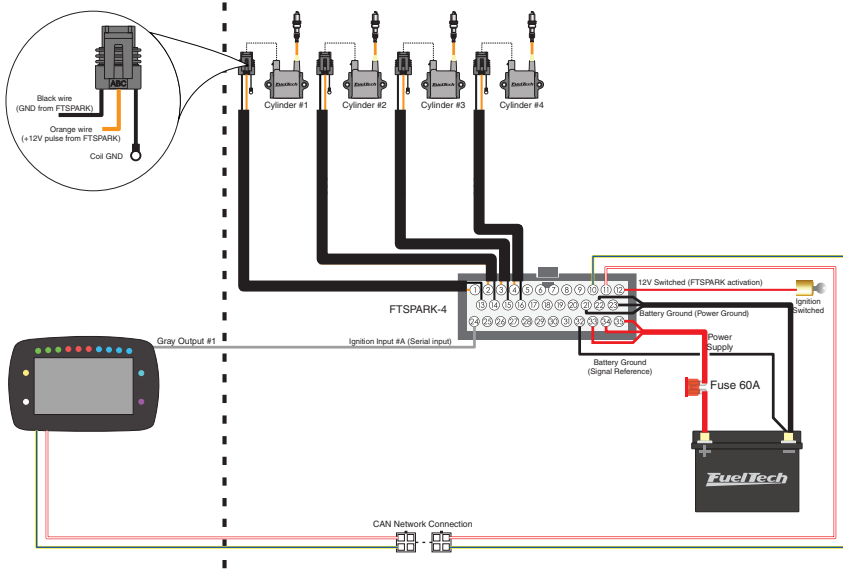

4 Cylinder with multiple wires

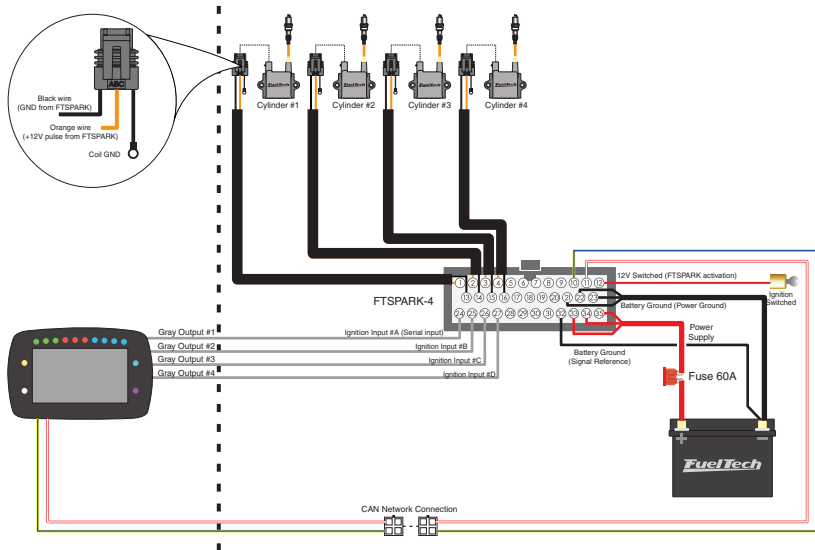

6 Cylinder with multiple wires

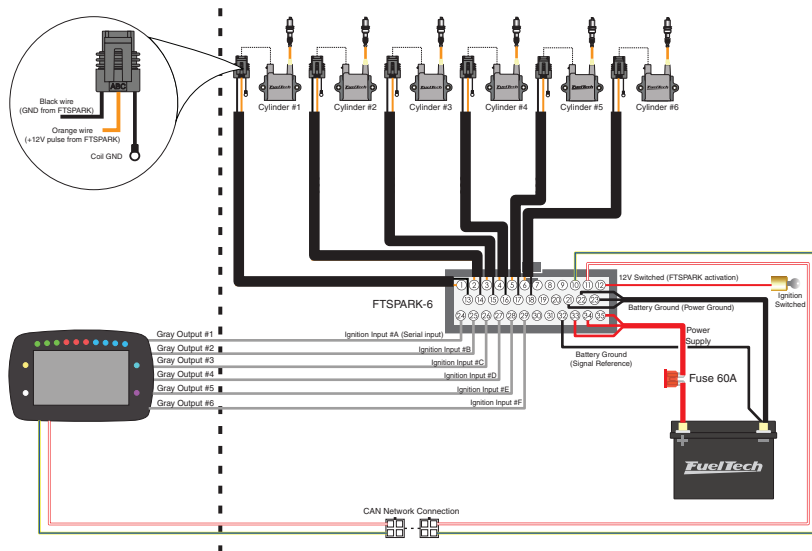

6 Cylinder with Serial bus (Single wire - only PowerFT ECU's and VisionFT ECU's)

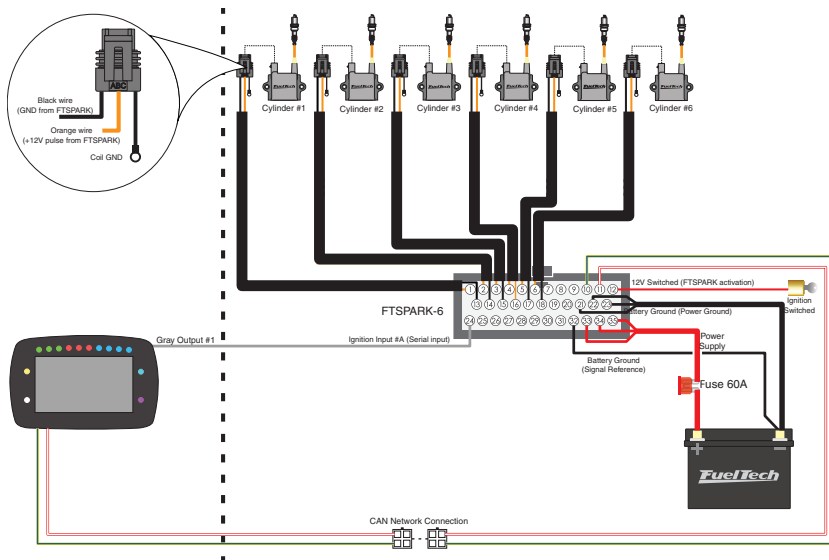

2 modules – 8 cylinders FTSPARK

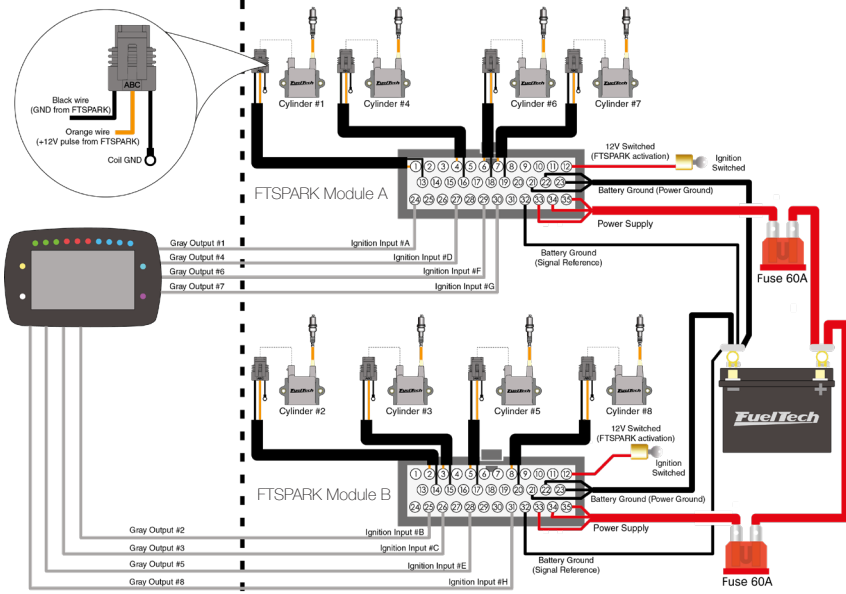

2 Modules for 8 Cylinders FTSPARK – Serial Mode (1-wire)

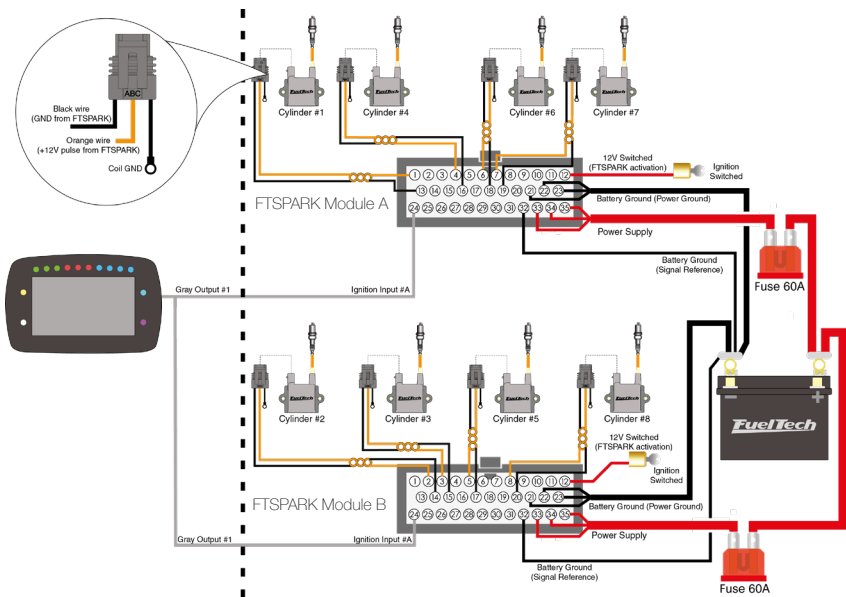

2 Rotors with individual coils

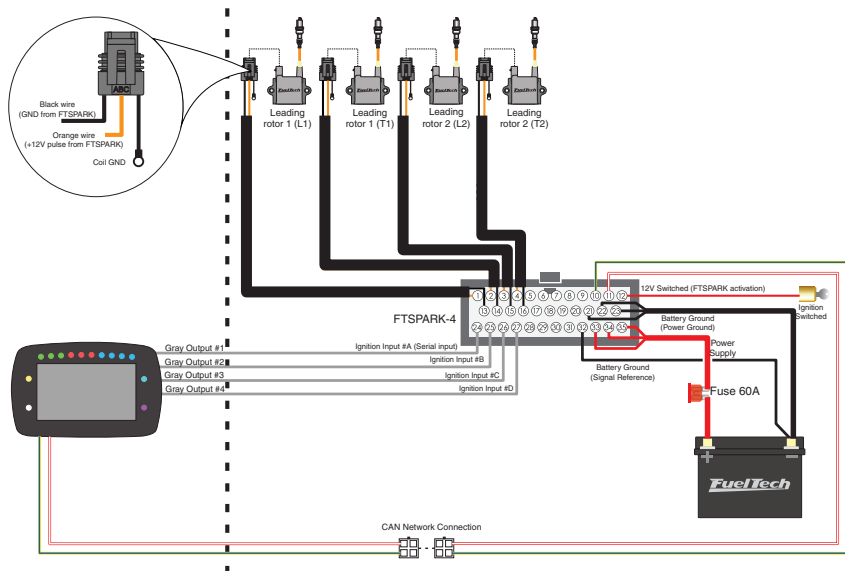

3 Rotors with individual coils - 2 FTSPARK boxes

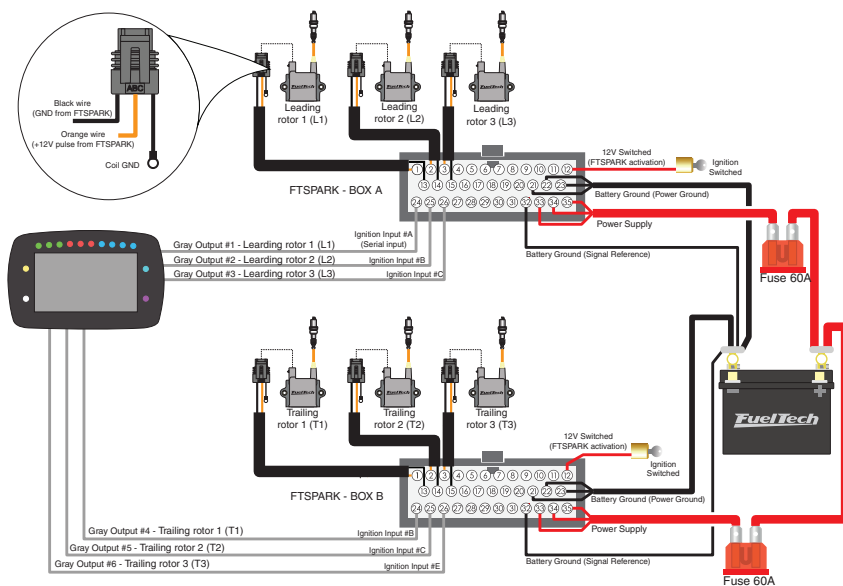

Ignition pins assignment - FTManager

After FTSPARK installation, follow the steps below if changes on the ignition outputs are needed:

- 1 - Open the map on FTManager.
- 2 - Click on "Sensors and calibration / Outputs".
- 3 - Check which gray outputs are set as ignition outputs. If you need to change output order, proceed to step 4.
- 4 - Click on "Engine settings / Advanced map options".
- 5 - Click on "Ignition pins assignment mode and change it from "Automatic" to "Manual".
- 6 - Return to the "Sensors and calibration / outputs" menu and change the ignition outputs according to your installation.

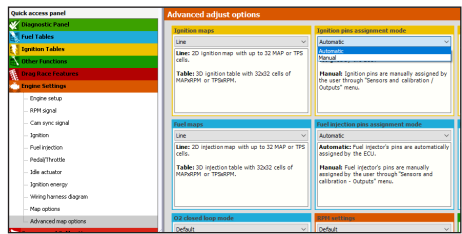

Ignition pins assignment - FuelTech Vision

If it is necessary to change the ignition outputs after installing the FTSPARK, follow the steps below:

- 1 - Open the map using FuelTech Vision.
- 2 - Access the "VCU settings / Outputs" menu.
- 3 - Check which gray outputs are configured as ignition outputs; if changes are required, proceed to step 4.
- 4 - Access the "Engine Settings / Ignition" menu.
- 5 - Click on "Pin Assignment mode" and change the setting from "Automatic" to "Manual".
- 6 - Return to the "VCU settings / Outputs" menu and reassign the ignition outputs as needed.



IMPORTANT

Any changes made to the settings must be saved to the VCU.

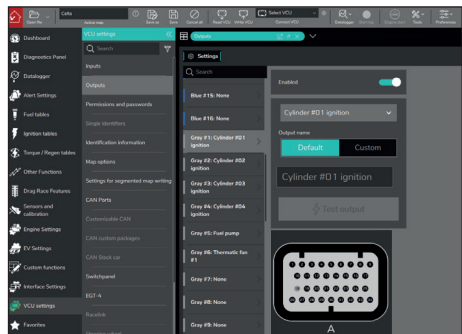
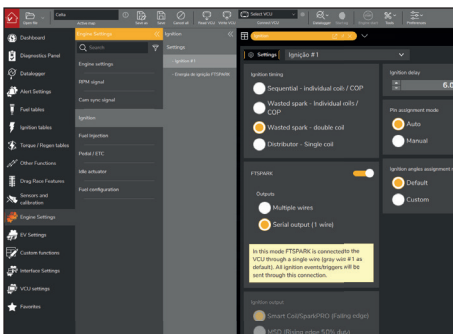

FTSPARK-4 managed by other aftermarket ECU's

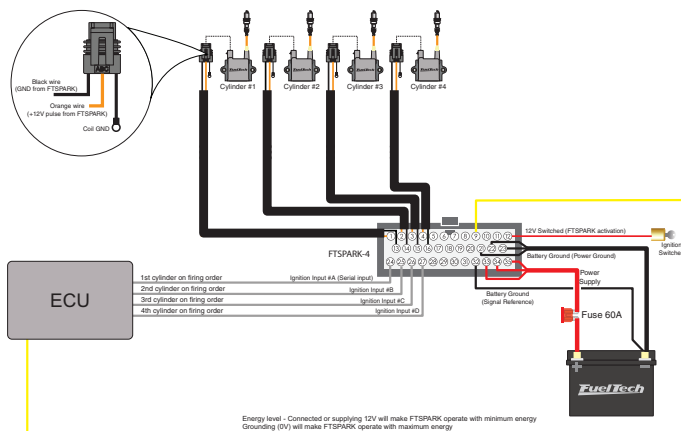

FTSPARK-6 managed by other aftermarket ECU's

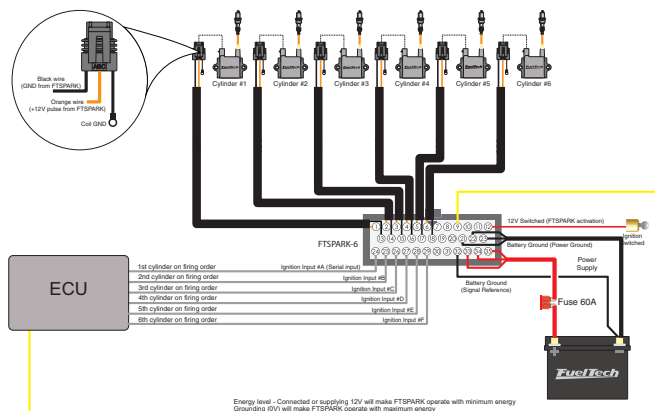

Electrical wire specifications

Function	Color / Wire Gauge
Ignition output (COILS)	Orange AWG 16 (1.5mm ²) isolation 750V
Ground ignition (COILS)	Black AWG 16 (1.5mm ²) isolation 750V
- BAT	Black AWG 16 (1.5mm ²) Isolation 300V until the splice and after AWG 10 (4.5mm ²)
+ BAT	Red AWG 16 (1.5mm ²) Isolation 300V until the splice and after AWG 10 (4.5mm ²)
Ignition input	Gray AWG 20 (0.5mm ²) Isolation 300V
Energy level	Yellow AWG 20 (0.5mm ²) Isolation 300V
12V	Red AWG 20 (0.5mm ²) Isolation 300V
ECU GND	Black AWG 20 (0.5mm ²) Isolation 300V

5.5 Wiring harness installation

The main connector terminals must be crimped with an appropriate crimping tool. Never weld terminals. Additional metal will cause electrical insulation problems inside the connector.

Plan the installation to avoid wiring joints on the wiring harness. If this is unavoidable, the twisted wires should continue to be braided in the extended part. Power outputs connected to the primary coil must use wires with a minimum 750V insulation.

5.6 Wiring harness positioning

Never route the output cables that connect the coils (59 in. Twisted orange cables) together with the other FTSPARK wires or other electrical wiring in the vehicle. The output cables that connect to the coils may induce a high amount of current in surrounding wires, which can cause malfunction in other systems of the vehicle and even damage inputs and outputs of other modules.

It's recommended to keep a distance of at least 4" between the ignition coils wiring and all other wiring harness parts. If this can't be done, the wiring should be covered with braided steel wiring sleeve.

5.7 Ground reinforcement

In cases where the normal noise generated by the FTSPARK is influencing other electronic components in the vehicle, it is recommended to ground the device's casing. Although it is already grounded internally, in some cases this reinforcement may be necessary. Do this as shown in the image, using eyelet-type terminals connecting the upper and lower parts of the FTSPARK mounting pad.

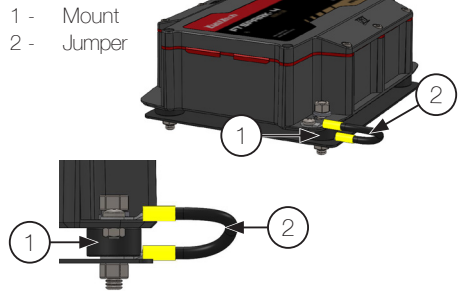

5.8 Coils

Use only coils that are approved and tested by FuelTech. The vast majority of coils designed for inductive operation greatly reduce the performance of the FTSPARK. A good inductive coil does not guarantee similar performance when used with the FTSPARK.

Some coils developed for use with OEM CDIs (nautical or motorcycle use) may damage the CDI they cannot absorb the peak power sent by FTSPARK. Below is the coil recommended by FuelTech.

Racing CDI FuelTech wiring diagram

- A - Black wire (GND from FTSPARK)
- B - Orange wire (+12 pulse from FTSPARK)
- C - Coil GND



IMPORTANT

Do not connect the shield to the negative of the coil.

Model	Manufacturer
CDI Racing Coil	FuelTech



IMPORTANT

The C pin ring terminal must be bolted on the cylinder head as close as possible to the spark plug that it's going to fire.

5.9 Spark plug wires

Do not use spark plug wires without suppression or cables with suppressor terminals only. Use of RFI (radio frequency interference) spark plugs wire is required to ensure the proper operation of all electronic equipment on the vehicle.

Low resistance spark plug wires with suppressive characteristics are recommended.

5.10 Spark plugs

Using non-resistive spark plugs greatly increases spark energy with capacitive ignitions, however not all installations will function properly depending on the level of interference generated. In these cases using resistive spark plugs is mandatory.

Keep the spark plugs clean and free of oil or grease to prevent electrical insulation problems.

Spark plugs that do not allow GAP adjustment or surface discharge are designed for use only in naturally aspirated engines. For turbocharged engines keep the spark plug GAP always less than 0.024 in.



WARNING

Faults in the ignition system due to excessive GAP damage the coils and also FTSPARK. When the energy released by the ignition cannot find a path to be dissipated, it returns to the coil or to the output of the FTSPARK output.

6. FTSPARK control

FTSPARK has two operation modes. Individual triggering (using two or more ignition outputs) or through Serial bus (1 wire).

6.1 Individual triggering

In this mode, FTSPARK operates using the signals present on IGNITION INPUT A through H. To configure it on both the Power FT line and the Vision FT line, simply enable the FTSPARK option and select multiple outputs. On other models, it is necessary to select the SparkPRO/3 wires option with a dwell time of 1ms. Longer or shorter dwell times may cause abnormal operation. The recommended input signal voltage is 0 V for low level and 5–14V for high level. Use the ECU NEGATIVE connected to the FT sensor ground output, or the battery negative in other situations, as the reference for these triggering signals.

6.2 Serial bus triggering

In this mode, FTSPARK operates using signals present in IGNITION INPUT A only. This mode allows more outputs to be used in other features and reduces the quantity of harness wires. This mode is only available when the FTSPARK is connected to an ECU of the Power FT product line or a Vision FT product line ECU.



NOTES

- This serial protocol is not compatible with any other ECU, it's a FuelTech exclusive compatibility.
- The serial bus triggering cannot be used for rotary engines.

6.3 Input signal trigger edge

All the FTSPARK units are designed to receive FALLING TRIGGER EDGE signal from the EFI, make sure you have your EFI settings for ignition output signal as falling edge to ensure accurate ignition timing.

6.4 CAN network

The CAN network allows the ECU to select the energy level without the use of the energy level selection wire. In addition, FTSPARK is capable of generating a series of CAN network diagnostics that are recorded by the ECU (FuelTech FT500 or higher).

CAN Network connection

FTSPARK harness has 2 connectors for CAN network connection with FuelTech products.

- 1 - Female connector
- 2 - Male connector
- 3 - CAN terminator

Plug the male connector from the FTSPARK harness (2) to the female connector on the back of the ECU. In case you have other products that are already connected to the CAN network (WB-O2 Nano, for instance), then connect the male connector from FTSPARK to the female connector from the WB-O2 Nano. It may be necessary to remove the CAN terminator from the WB-O2 Nano harness.

The CAN terminator (3) must remain plugged to the female connector of the last equipment on the network. This helps to prevent noise on the CAN network.

Male connector from the FTSPARK (1) MUST NOT be plugged to the female connector on the same harness. Connecting as shown ensures proper CAN communication.

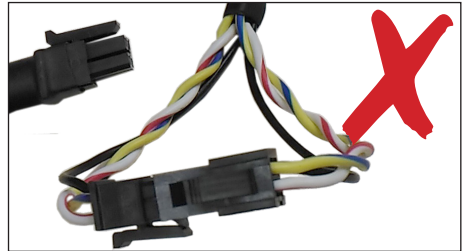
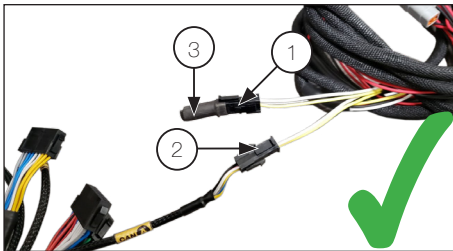

WARNING

When the CAN network is disconnected, the user loses the option of selecting the energy level through the MAP and visualizing all the diagnostics and measures that the ignition module is capable of performing.

Through the diagnostic panel it's possible to identify if the FTSPARK is connected. If it's not connected, the product will operate normally (with energy set by the energy setting wire).

For proper CAN communication (log/maps) operation, always use the latest version of the software.

6.5 Energy level selection

Energy level may be selected in two ways: ENERGY LEVEL input ground trigger (pin 9, yellow cable), or through CAN network (values are set in the ECU's ignition energy table).



IMPORTANT

To operate with 1000–2000mJ of energy and with control by other fuel injection brands, it is necessary to connect to ground or to an auxiliary output (Pin 9, yellow wire). If this wire is not connected, the FTSPARK will operate with only 250mJ.

Operation with CAN network

When the CAN network is connected to a FuelTech ECU, the ENERGY LEVEL input is ignored and the energy level is set by the ECU via CAN.



WARNING

If the internal operating temperature exceeds 176 °F, the FTSPARK activates protection mechanisms to prevent damage to the electronic components, regardless of user programming, may cause engine misfires.

FTManager

When using the PowerFT line and configuring the FTSPARK via the CAN network, it is necessary to check the “Send fixed data packet” option so that the FTSPARK follows the values configured in the energy table and provides the correct diagnostic information to the ECU.

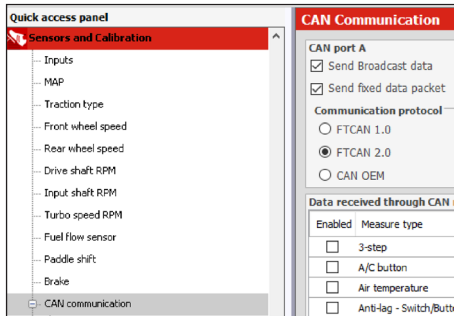

FuelTech Vision

When using the VisionFT line, it is important to ensure that the serial port used by the FTSPARK is enabled in the electronics. To do so, access “VCU settings / CAN Ports.” Set the operating mode to “FTCAN 2.0” and enable real-time data transmission.

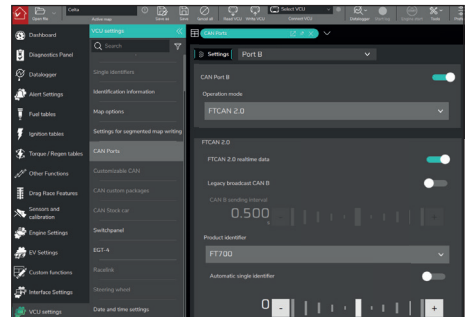

Operation without CAN network

Select energy level through ENERGY LEVEL input:

- 250mJ: Do not connect ENERGY LEVEL input.
- 1000-2000mJ (depending on the engine's speed): ENERGY LEVEL input must be connected to a ground or auxiliary output.



NOTES

- 2000mJ (minimum guaranteed energy, limited according to the table below)
- 1000mJ (minimum guaranteed energy up to maximum engine speed)

Energy limits with or without CAN network

The maximum RPM limit of the FTSPARK at maximum energy depends on two factors: the electronic module model and the battery voltage.

FTSPARK-4			
RPM	13V	16V	25V
1000	2000	2000	2000
2000	2000	2000	2000
3000	2000	2000	2000
4000	2000	2000	2000
5000	2000	2000	2000
6000	2000	2000	2000
7000	2000	2000	2000
8000	2000	2000	2000
9000	1750	2000	2000
10000	1500	2000	2000
11000	1400	2000	2000
12000	1250	1800	1900

FTSPARK-6			
RPM	13V	16V	25V
1000	2000	2000	2000
2000	2000	2000	2000
3000	2000	2000	2000
4000	2000	2000	2000
5000	2000	2000	2000
6000	2000	2000	2000
7000	1500	2000	2000
8000	1300	2000	2000
9000	1100	1800	2000
10000	950	1600	2000
11000	850	1400	1800
12000	750	1200	1600

FTSPARK-8			
RPM	13V	16V	25V
1000	2000	2000	2000
2000	2000	2000	2000
3000	2000	2000	2000
4000	2000	2000	2000
5000	1500	2000	2000
6000	1200	2000	2000
7000	1000	1800	2000
8000	800	1600	2000
9000	700	1400	1800
10000	650	1200	1600
11000	600	1000	1400
12000	550	800	1200

Two FTSPARK Boxes (4 channels per Unit)			
RPM	13V	16V	25V
1000	2000	2000	2000
2000	2000	2000	2000
3000	2000	2000	2000
4000	2000	2000	2000
5000	2000	2000	2000
6000	2000	2000	2000
7000	2000	2000	2000
8000	2000	2000	2000
9000	1750	2000	2000
10000	1500	2000	2000
11000	1400	2000	2000
12000	1250	1800	1900

6.6 Wasted spark operation

The FTSPARK has 2 banks of capacitors that are alternately connected at the outputs. The first bank of capacitors fires the “odd” outputs, which are designated A, C, E and G, and the second bank fires the “even” outputs, designated B, D, F and H.

For the FTSPARK to operate properly in wasted spark mode, the installation must alternate the sparks between the capacitor banks; that is, one spark on an “odd” bank and the next on an “even” bank, and so on. Doing so will allow the operation on rotary engines (which has the sparks timed very close to each other) and wasted spark on engines with up to 4 cylinders.



WARNING

It is recommended to use FTSPARK always in sequential ignition mode, using wasted spark mode in 4-cylinder engines guarantees operation up to 10000RPM with energy reduction, but the extra effort will reduce the product life.



IMPORTANT

Only engines with 4 cylinders or less can use the wasted spark configuration. Engines with 5 to 8 cylinders must use sequential ignition.

6.7 Safety Features

The FTSPARK has many internal safety protections to avoid damage to the product in case of misuse or improper installation.

Every failure is automatically reset, that is, if the error is gone, the FTSPARK resumes operation normally.

Some protections require special attention.

The errors 41 and 43, which are related to a failure to charge the internal capacitors, prevent the FTSPARK from functioning if they occur 10 consecutive times. Normal operation is resumed when trigger signal is removed. Removing the power is not needed.

Error 22 indicates electronic operation in overtemperature conditions. The protection acts gradually, reducing the energy from 2000mJ to 150mJ as the temperature increases between 176 °F and 212 °F. From 212 °F onward, the energy remains fixed at 150mJ. When 230 °F is reached, the FTSPARK shuts down its outputs to prevent damage caused by overheating.

Temperature (°F)	Energy (mJ)
< 176	2000 - 150
Between 176 and 212	1000 - 150
> 212	150
> 230	0

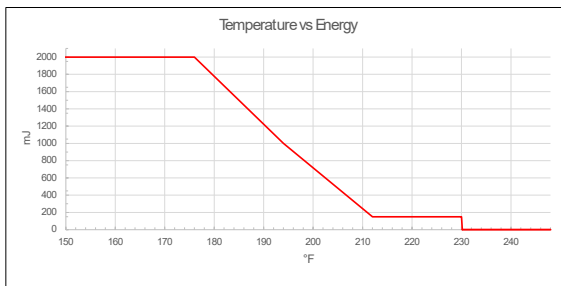

6.8 Ignition delay time

The FTSPARK has a predefined "Ignition delay" between processing the input signal and firing the ignition of 30µs (0.000030 second) that should be added to the existing ignition delay time set on the ECU when switching from another ignition system that has close to zero delay.

Typical ignition delay time of a complete ECU, ignition system, coil and spark wires are 70µs. To confirm this setting on your system, lock the ignition timing advance to a fixed timing and check with a timing light that you have no timing change over the RPM range from idling to high RPM, this means that your "ignition delay" was set correctly. If you experience timing being retarded over RPM, you need to increase the "ignition delay".

As a reference number, on a sequential ignition setup with locked timing on ECU, if you are checking timing at 1,000 RPM and then at 9,000 RPM and timing is retarding 1 degrees over this range, you will need to add 20µs to the "ignition delay" on the ECU.

7. Recalibrating ignition and fuel map

The additional energy generated and precise ignition timing (related to short spark duration), generally require ignition map to be recalibrated when FTSPARK is installed to replace an inductive system.

The additional spark energy allows the engine to operate with richer mixtures before misfire or loss of power. It's possible to take advantage of this and operate with a richer fuel map for the same power level, putting the engine in a safer range of operation avoiding all the problems that might occur when running with a lean mixture.

8. LED operation indicator

FTSPARK has a LED that allows to diagnose its basic operation. Its possible states are listed in the table below.

State	Diagnostic
Off	No power input switched 12V
Steady Green	FTSPARK is on, no errors, waiting triggering pulses
Blinking Green	Triggering pulses on input, no errors, operating with standard energy (< 400mJ)
Blinking Orange	Triggering pulses input, no errors, operating with maximum energy (> 750 mJ)
Blinking red/green alternately.	The FTSPARK can indicate an error code on the diagnostic LED composed of two digits. Red flashes indicate the tens digit, and green flashes indicate the units digit. Example: 4 red flashes followed by 3 green flashes. Error code 43.

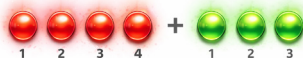

Error Code: 43

Following is the list of errors currently reported by the FTSPARK.

Error Code	Diagnose	Solution
02	FTSPARK has restarted operation	It usually occurs due to ignition interference. Check the electrical installation of the ignition coil harness and grounding.
21	ECU is operating on wasted spark with wrong firing order.	When activating two outputs simultaneously, it's mandatory to trigger one even and one odd channel. Example: AB, CD, EF, GH. * A = 1 B = 2 C = 3 ... H = 8
22	FTSPARK has overheated	Increase the airflow around FTSPARK or turn it off so it can cool down to its normal operating temperature.
31	Off Power Supply	Check the power supply circuit the FTSPARK, relays and fuses.
41	Hardware error. Over voltage on internal capacitors.	Contact FuelTech.
42	Hardware error. Internal voltage below minimum. FTSPARK switches off during this fault condition.	It may be caused by a power failure on FTSPARK or discharged battery.
43	Hardware error. FTSPARK cannot charge the capacitors.	Probable output failure. Contact FuelTech.
44	Hardware error. FTSPARK has internal protection fuse ruptured	This fuse is not accessible and cannot be replaced by the user. Contact FuelTech.

9. FTSPARK settings and operation

9.1 FTSPARK settings in FTManager software

Through FTManager it's possible to configure the FTSPARK output, to do so go to 'Engine Settings' then 'Ignition'. Set FTSPARK to 'Enabled' then select the output.

Multiple wires: This mode will activate individual coil outputs.

Serial bus (1 wire): In this mode the connection with the FTSPARK is made on the IGNITION INPUT A (gray wire #1). All of the ignition signals will be sent through this connection.

When the multiplexed output is selected, it's possible to test the FTSPARK outputs using a "test function" on the FTManager. To do so, go to 'Sensors and Calibration' then 'Outputs' and select FTSPARK - Output test.

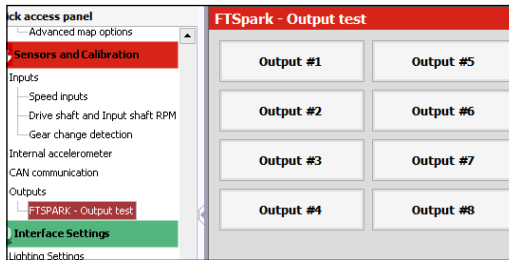

Ignition energy

On this MAPxRPM table it's possible to set the energy level of the FTSPARK. Adjust this table according to the FTSPARK maximum and minimum possibilities.



Base values to be reviewed by a tuner
Fill the energy table with 2000 mJ. In the absence of CAN/ECU, connect pin 9 to ground to enable up to 2000 mJ; otherwise, the system will operate limited to 250 mJ.

		MAP (psi)					
		-14.50	-10.15	-4.35	0.00	14.50	29.01
RPM (rpm)	9000	750	750	750	750	750	750
	7000	750	750	750	750	750	750
	5000	750	750	750	750	750	750
	3000	400	400	400	400	750	750
	1000	400	400	400	400	750	750
	1000	400	400	400	400	750	750

Using two FTSPARK units in the same installation:

When the installation requires 2 FTSPARK units, it's necessary to identify which unit will be the Box B, using FuelTech FTManager software.

Procedure:

1. Connect both units in the CAN bus along with the FuelTech PowerFT ECU.
2. Turn ignition ON to power FTSPARK boxes.
3. Under the tab Tools, in the top of the software, select CAN Network.
4. In the case that the units are all Box A, the product icon in the left column will show up as just one. Click on top of the product and select the module you want to identify according to it's serial number to become the Box B and select "Identify" to blink the desired product LED, after that just click "Save". All new modules are configured as "Box A" as default.

For rotary engines with 3 or 4 rotors, is required 2 FTSPARK-4 units, the second one that will trigger "Trailing" spark plugs must be configured as Box B.



NOTE

On step 4, if having difficulty changing unit assignment, unplug the Box A that will be used in the installation and let only the unit that will be renamed connected to CAN.

Channel	Port	Sensor	Measure Type	Value
1	Port A	FTSPARK	Discharge time output #2	0 us
2	Port A	FTSPARK	Discharge time output #3	0 us
3	Port A	FTSPARK	Discharge time output #5	0 us
4	Port A	FTSPARK	Discharge time output #8	0 us
5	Port A	FTSPARK	Supply voltage of module #2	0.087 V
6	Port A	FTSPARK	Supply voltage drop of module #2	0.000 V
7	Port A	FTSPARK	Ignition energy of module #2	1 mJ
8	Port A	FTSPARK	Internal temperature of module #2	56.9 °F
9	Port A	FTSPARK	#1 capacitor voltage of module #2	15.0 V

Version: N/A | Hardware: N/A | Language: N/A | Serial: N/A

FTSpark

9.2 FTSPARK settings in FuelTech Vision software

When using the VisionFT line, it is necessary to configure the FTSPARK output through the FuelTech Vision software. To do so, access the Engine Settings menu and then the Ignition menu. Enable FTSPARK and then select the desired output type.

Multiple wires: This mode will activate individual coil outputs.

Serial bus (1 wire): In this mode the connection with the FTSPARK is made on the IGNITION INPUT A (gray wire #1). All of the ignition signals will be sent through this connection.

When the multiplexed output is selected, its possible to test the FTSPARK outputs using a "test function" on the FuelTech Vision. To do so, go to 'VCU settings' then 'Outputs' and select FTSPARK - Output test.

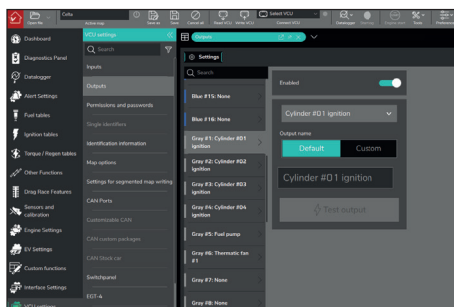
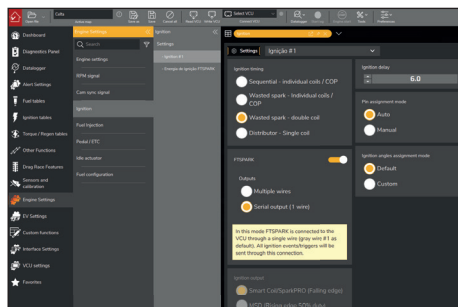

Ignition energy

On this MAP x RPM table it's possible to set the energy level of the FTSPARK. Adjust this table according to the FTSPARK maximum and minimum possibilities.



Base values to be reviewed by a tuner

Fill the energy table with 2000 mJ. In the absence of CAN/ECU, connect pin 9 to ground to enable up to 2000 mJ; otherwise, the system will operate limited to 250 mJ.



9.3 Spark duration (Multispark mode)

In this MAP x RPM table, it is possible to configure the FTSPARK spark duration in degrees. The energy defined in the energy map will be divided into multiple smaller sparks to achieve the desired duration. The time between sparks is 200 μ s. **Example:** Energy = 2000 mJ. A duration in degrees equivalent to 4 grouped smaller sparks. The energy for each smaller spark will be 2000 / 4 = 500 mJ.



Beware of spark plug overheating under extreme conditions!

With high energy and long spark duration, localized heating at the spark plug may occur. In vehicles tuned near the lean limit—such as methanol setups close to detonation—adding 1500 mJ where 750 mJ was previously used can lead to spontaneous ignition (dieseling effect) due to the additional heat at the plug. Carefully evaluate both spark duration and energy during the tuning process.



Base values to be reviewed by a tuner

Set the spark duration table to $\geq 20^\circ$ at low load and $\sim 1^\circ$ at high load. The logic is inverse (leaner mixtures require longer duration). The interval between arcs is fixed at 200 μ s.

FT Manager

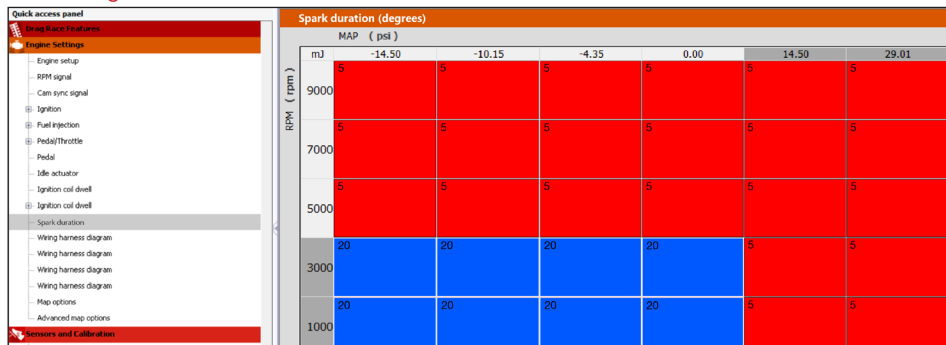

FuelTech Vision FT

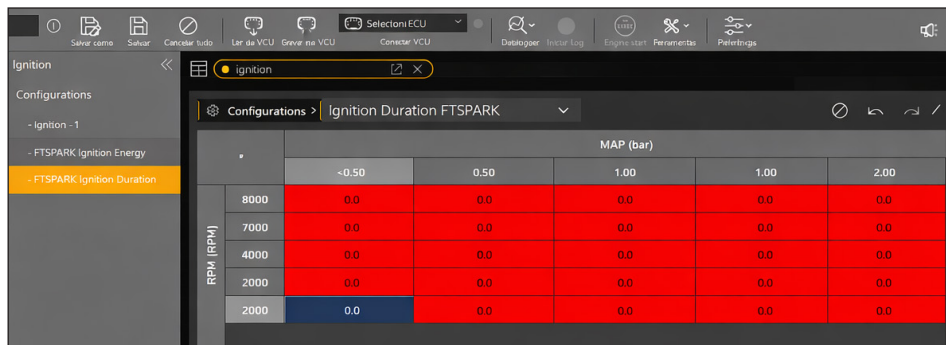

9.4 Setup on engines with sequential ignition

Sequential ignition setup on engines with individual coils.

8 Cylinders – Operation with 2 Modules	
Output	Cylinder
A (BOX A)	#1
B (BOX B)	#2
C (BOX B)	#3
D (BOX A)	#4
E (BOX B)	#5
F (BOX A)	#6
G (BOX A)	#7
H (BOX B)	#8

4 cylinders - FTSPARK-4	
Output	Cylinder
A	#1
B	#2
C	#3
D	#4

5 cylinders - FTSPARK-6	
Output	Cylinder
A	#1
B	#2
C	#3
D	#4
E	#5
F	Not used

6 cylinders - FTSPARK-6	
Output	Cylinder
A	#1
B	#2
C	#3
D	#4
E	#5
F	#6

8 cylinders - FTSPARK-8	
Output	Cylinder
A	#1
B	#2
C	#3
D	#4
E	#5
F	#6
G	#7
H	#8

Wasted setup spark on engines with 4 cylinders

VW (1-3-4-2) / motorcycles (1-2-4-3)	
Output	Cylinder
A	#1
B	#4
C	#3
D	#2

Subaru (1-3-2-4)	
Output	Cylinder
A	#1
B	#2
C	#3
D	#4

FT (1-2-3-4) / VW Air- cooled (1-4-3-2)	
Output	Cylinder
A	#1
B	#3
C	#2
D	#4

ROTARY setup engines.

The order must be altered so that the Leading and Trailing outputs of the same rotor are placed in sequence, as shown in the table below.



WARNING

The setup on the following table is mandatory on a ROTARY engine, because the “Trailing” and “Leading” coils will fire practically at the same time and they must be on different capacitor banks to ensure the maximum energy available.

3 rotors - 2 X FTSPARK-4	
Output	Rotor
A - FTSPARK (BOX A)	Leading rotor 1 (L1)
B - FTSPARK (BOX A)	Leading rotor 2 (L2)
C - FTSPARK (BOX A)	Leading rotor 3 (L3)
D - FTSPARK (BOX A)	-
A - FTSPARK (BOX B)	Trailing rotor 1 (T1)
B - FTSPARK (BOX B)	Trailing rotor 2 (T2)
C - FTSPARK (BOX B)	Trailing rotor 3 (T3)
D - FTSPARK (BOX B)	-

4 rotors - 2 X FTSPARK-4			
Output	Rotor	Output	Rotor
A - FTSPARK (BOX A)	Leading rotor 1 (L1)	A - FTSPARK (BOX B)	Trailing rotor 1 (T1)
B - FTSPARK (BOX A)	Leading rotor 2 (L2)	B - FTSPARK (BOX B)	Trailing rotor 2 (T2)
C - FTSPARK (BOX A)	Leading rotor 3 (L3)	C - FTSPARK (BOX B)	Trailing rotor 3 (T3)
D - FTSPARK (BOX A)	Leading rotor 4 (L4)	D - FTSPARK (BOX B)	Trailing rotor 4 (T4)

2 rotors - FTSPARK-4				
Output	A	B	C	D
Rotor	Leading rotor 1 (L1)	Trailing rotor 1 (T1)	Leading rotor 2 (L2)	Trailing rotor 2 (T2)

9.5 Datalogger channels

Discharge time: Each output has an individual monitoring channel for the discharging time on the coil, which allows to diagnose malfunctions on the coils, channels or harness. The discharge time of the capacitor is not related to spark time, a long discharge might indicate problems on the coil or harness and connector.

Supply voltage: shows the effective voltage received by the FTSPARK.

Supply voltage drop: shows the difference of the voltage supply between the FTSPARK and the ECU. In case this value is too high, there might be a problem on the power harness of the FTSPARK.

Capacitor voltage 1 and 2: FTSPARK has two banks of capacitors that are charged and discharged alternately on the outputs, allowing higher engine rotations and operation on ROTARY engines, the first bank of capacitors fires the outputs A-C-E-G and the second bank fires the outputs B-D-F-H.

Capacitor charge time 1 and 2: The monitoring of the charging time allows the diagnostic of a possible internal problem on the FTSPARK, power deficiency or RPM limit settings where the required charging time cannot be respected.

Energy Differences in the Log: It is normal for the FTSPARK to display an energy value in mJ that is close to, but not exactly equal to, the target value. The FTSPARK features an internal control loop that dynamically adjusts the discharge.

9.6 Status Events Information

Message	Possible causes	Solutions
Output # damaged	Output is damaged	Send to FuelTech's technical assistance
Output disabled	WARNING indicating that an output has been disabled due to a fault or overtemperature condition.	This message is always displayed along with the reason that caused the shutdown.
Low voltage on the 12V switch	Voltage below 12V	Check the battery or a harness problem
Low voltage on the 15V power supply	Internal problem.	Send to FuelTech's technical assistance
Charging circuit cannot load the capacitors	This message is always displayed along with the reason that caused the shutdown.	It may be a hardware problem or the positive power disconnected/off.
Overvoltage on high voltage bus	WARNING that the capacitor voltage exceeded 530V.	It cannot exceed 530V. If it exceeds the unit has to be sent to FuelTech's technical assistance.
Incorrect firing order	Wire connection is wrong when operating in wasted spark mode	Adjust the ignition order.
Internal fuse blown	Internal problem.	Send to FuelTech's technical assistance
Unexpected restart during operation	Generally caused by interference or an electrical issue in the installation.	Check the installation, power grounds, ignition grounds, spark plugs, and spark plug wires.
Low voltage on the power supply	It may be an electrical problem (harness, connectors or kill switch) or a battery problem.	Check the battery and the wiring harness.
Power stage temperature exceeded 212 ° F	Severe use under not recommended conditions by FuelTech	Check the recommended conditions on this manual
Module restarted unexpected during spark	This problem is caused by ignition interference/noise.	Check spark plugs cables, spark plugs, coil harness route, etc.
Pulse not recognized	In serial mode, it received a signal out of specification.	It is usually a harness or harness route problem.
No load connected at output	There is nothing connected at the output	Check the harness, coil and connectors
Output with partial discharge	The coil is not consuming all energy sent by FTSPARK	Check the harness, coil and connectors

10. FT CAN 2.0 protocol

The FTSPARK features advanced diagnostics for operation, faults, and issues, greatly assisting in monitoring and troubleshooting the ignition system. When used in conjunction with FuelTech Power FT series ECUs (FT450 or higher), or with the Vision FT line (all models), this configuration is already implemented in the ECU, and no additional programming is required to access all of this information. However, when the FTSPARK is used with another ECU or with a data acquisition system that features a CAN communication port and is programmable, full access to all of these data is available, allowing complete use of the FTSPARK's capabilities and benefits.



NOTE

The CAN 2.0 protocol is available on our website under the manuals section. Contact your ECU or data acquisition system manufacturer for instructions on how to make CAN programming according to this document.

10.1 Physical layer

CAN 2.0B extended mode
Rate: 1Mbps

10.2 Operation

The FTSPARK receives spark energy and spark duration information in fixed, single packets. Each packet carries a different piece of information. There is no sequence or requirement to send both packets; whichever information is available on the CAN bus will be used.

The FTSPARK transmits diagnostic channel packets on the CAN network. Each CAN packet is individually decodable, with no dependency on previous or subsequent packets. Only one diagnostic channel is transmitted per packet.

10.3 Setting the Energy Level via CAN

The FTSPARK can receive a CAN packet that specifies the energy level to be used. The format of this packet is shown in the table below.

DATA								
ID (29bits)	D0	D1	D2	D3	D4	D5	D6	D7
xxxxx12FF	0xFF	DataID (0x00 and 0xE8)		Channel Data		-	-	-

Notes

- Any ID ending with 12FF is valid to receive the information;
- The first three bytes must be: 0xFF 0x00 0xE8;
- The timeout for this information is 5s. Recommended transmission rate: 1–10Hz.

Example:

Send 1000mJ (0x03E8):
ID = 0x140012FF data: FF 00 E8 03 E8

10.4 Setting the Spark Duration

Degrees

The FTSPARK can receive a CAN packet that specifies the spark duration in degrees. The format of this packet is shown in the table below.

DATA								
ID (29bits)	D0	D1	D2	D3	D4	D5	D6	D7
xxxxx12FF	0xFF	DataID (0x05 and 0x4E)		Channel Data		-	-	-

Notes

- Any ID ending with 12FF is valid to receive the information;
- The first three bytes must be: 0xFF 0x05 0x4E;
- The timeout for this information is 5 s. Recommended transmission rate: 1–10Hz

Example:

Send 20 ° (0x00C8):
IID = 0x140012FF data: FF 05 4E 00 C8

Microseconds

The FTSPARK can receive a CAN packet that specifies the spark duration in microseconds. The format of this packet is shown in the table below.

DATA								
ID (29bits)	D0	D1	D2	D3	D4	D5	D6	D7
xxxxx12FF	0xFF	DataID (0x05 and 0x50)		Channel Data		-	-	-

Notes

- Any ID ending with 12FF is valid to receive the information;
- The first three bytes must be: 0xFF 0x05 0x50;
- The timeout for this information is 5 s.
Recommended transmission rate: 1–10Hz

Example:

Send 1000 μ s (0x3E8):
IID = 0x140012FF data: FF 05 50 03 E8



NOTE

If both channels are transmitted, the FTSPARK prioritizes the time channel.

10.5 Transmitted Diagnostic Channels

The FTSPARK transmits a fixed CAN frame containing diagnostic channels. Only one diagnostic channel is transmitted per CAN packet. The format of this packet is shown in the table below.

DATA								
ID (29bits)	D0	D1	D2	D3	D4	D5	D6	D7
0x124012FF	0xFF	DataID		Channel Data		-	-	-

Notes

- The ID is fixed at 0x124012FF;
- The first byte is fixed at 0xFF;
- The transmission rate may be 50Hz, 25Hz, or 10Hz, depending on the information;
- The table with the DataID associated with each channel is available in Chapter 10.6.

10.6 MeasureIDs

The detailed description of each MeasureID is provided in the table below.

MeasureID	DataID	Description	Unity	Multiplier	Broadcast source (rate*)
0x00A4	0x0052	External Ignition output 1 discharge time	uS	1	FTSPARK 50Hz
0x00A6	0x0053	External Ignition output 2 discharge time			
0x00A8	0x0054	External Ignition output 3 discharge time			
0x00AA	0x0055	External Ignition output 4 discharge time			
0x00AC	0x0056	External Ignition output 5 discharge time			
0x00AE	0x0057	External Ignition output 6 discharge time			
0x00B0	0x0058	External Ignition output 7 discharge time			
0x00B2	0x0059	External Ignition output 8 discharge time			
0x00B4	0x005A	External Ignition output 9 discharge time			
0x00B6	0x005B	External Ignition output 10 discharge time			
0x00B8	0x005C	External Ignition output 11 discharge time			
0x00BA	0x005D	External Ignition output 12 discharge time			
0x00BC	0x005E	External Ignition output 13 discharge time			
0x00BE	0x005F	External Ignition output 14 discharge time			
0x00C0	0x0060	External Ignition output 15 discharge time			
0x00C2	0x0061	External Ignition output 16 discharge time			
0x00C4	0x0062	External Ignition Power Supply	V	.001	
0x00C6	0x0063	External Ignition Power Supply Drop			
0x00C8	0x0064	External Ignition Power Level	mJ	1	
0x00CA	0x0065	External Ignition Temperature	°C	0.1	
0x00CC	0x0066	External Ignition Capacitor 1 charge	V	0.1	
0x00CE	0x0067	External Ignition Capacitor 2 charge			
0x00D0	0x0068	External Ignition Capacitor 3 charge			
0x00D2	0x0069	External Ignition Capacitor 4 charge			
0x00D4	0x006A	External Ignition Capacitor 1 charge time	uS	1	
0x00D6	0x006B	External Ignition Capacitor 2 charge time			
0x00D8	0x006C	External Ignition Capacitor 3 charge time			
0x00DA	0x006D	External Ignition Capacitor 4 charge time			
0x00DC	0x006E	External Ignition Error code	-	Note 1	
0x00DE	0x006F	External Ignition no load outputs	-	Note 2	FTSPARK 25Hz
0x00E0	0x0070	External Ignition partial discharge outputs	-		
0x00E2	0x0071	External Ignition damaged outputs	-		
0x00E4	0x0072	External Ignition disabled outputs	-		
0x00E6	0x0073	External Ignition operation status	-	Note 3	
0x022C	0x0116	External Ignition Switch voltage	V	0.001	
0x022E	0x0117	External Ignition CPU supply voltage			
0x0230	0x0118	External Ignition CPU temperature	°C	0.1	

MeasureID	DataID	Description	Unity	Multiplier	Broadcast source (rate*)
0x00DC	0x006E	External Ignition Error code	-	Note 1	FTSPARK 25Hz
0x00DE	0x006F	External Ignition no load outputs	-	Note 2	
0x00E0	0x0070	External Ignition partial discharge outputs	-		
0x00E2	0x0071	External Ignition damaged outputs	-		
0x00E4	0x0072	External Ignition disabled outputs	-		
0x00E6	0x0073	External Ignition operation status	-	Note 3	
0x022C	0x0116	External Ignition Switch voltage	V	0.001	
0x022E	0x0117	External Ignition CPU supply voltage			
0x0230	0x0118	External Ignition CPU temperature	°C	0.1	
0x0232	0x0119	External Ignition operation time	S	0.1	
0x02A8	0x0154	External Ignition Power Supply – B	V	.001	FTSPARK 50Hz
0x02AA	0x0155	External Ignition Power Supply Drop - B			
0x02AC	0x0156	External Ignition Power Level – B	mJ	1	FTSPARK 50Hz
0x02AE	0x0157	External Ignition Temperature - B	°C	0.1	
0x02B0	0x0158	External Ignition Capacitor 1 charge - B	V	0.1	
0x02B2	0x0159	External Ignition Capacitor 2 charge – B			
0x02B4	0x015A	External Ignition Capacitor 3 charge – B			
0x02B6	0x015B	External Ignition Capacitor 4 charge – B			
0x02B8	0x015C	External Ignition Capacitor 1 charge time – B	uS	1	
0x04E6	0x0273	Spark duration for external ignition	°	0.1	

Note 1

- **Bit 0:** Unknown pulse width received by the FT Ignition Bus.
- **Bit 1:** Incorrect ignition order in semi-sequential operation.
- **Bit 2:** Over voltage in the high voltage bus. (external ignition disabled until next power cycle).
- **Bit 3:** Under voltage in the output drivers power supply. (external ignition disabled while condition exists).
- **Bit 4:** Charge circuit unable to charge capacitors.
- **Bit 5:** Power supply under voltage.
- **Bit 6:** 12V switch under voltage.

Note 2

Bit 0:	Output #1	Bit 8:	Output #9
Bit 1:	Output #2	Bit 9:	Output #10
Bit 2:	Output #3	Bit 10:	Output #11
Bit 3:	Output #4	Bit 11:	Output #12
Bit 4:	Output #5	Bit 12:	Output #13
Bit 5:	Output #6	Bit 13:	Output #14
Bit 6:	Output #7	Bit 14:	Output #15
Bit 7:	Output #8	Bit 15:	Output #16

Note 3

- Bit 0: Internal use
- Bit 1: Internal use
- Bit 2: High power mode enabled

11. Dimensions

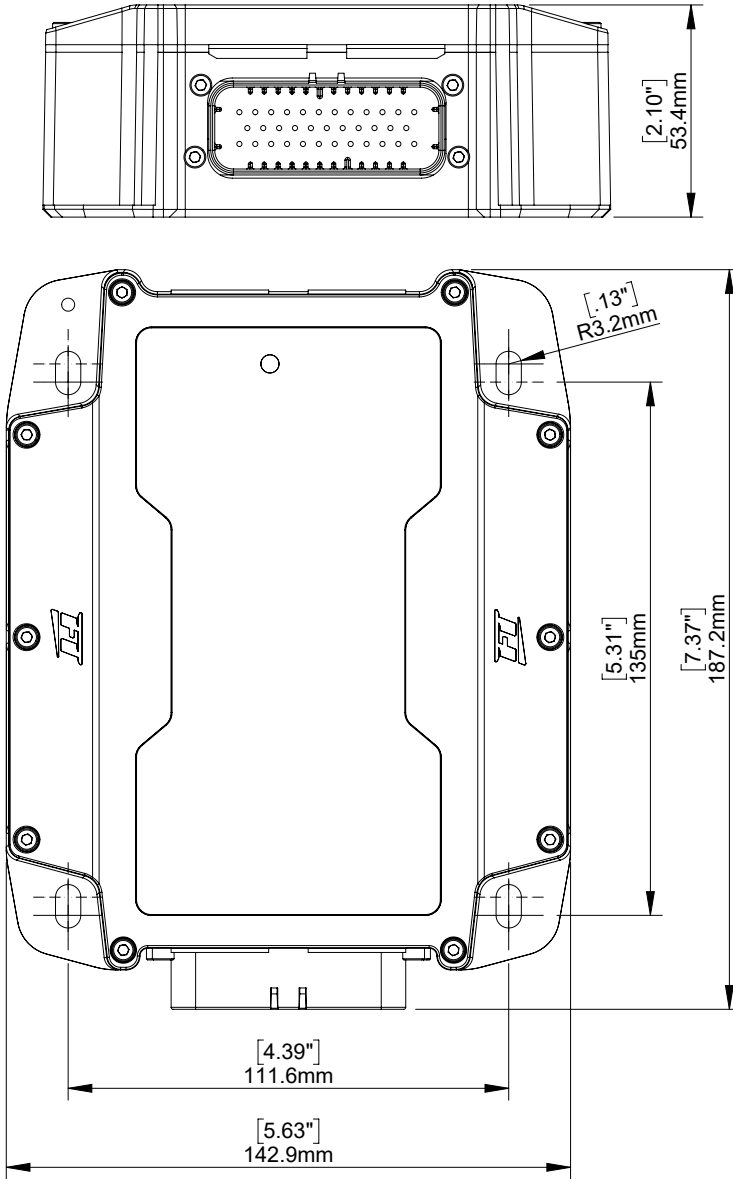



USA

FuelTech USA, 455 Wilbanks Dr.
Ball Ground, GA, 30107, USA
Phone: +1 678-493-3835
info@fueltech.net
www.FuelTech.net

BRASIL

FuelTech Ltda, Av. das Indústrias,
864, Bairro Anchieta | CEP 90200-290,
Porto Alegre, RS, Brasil
CNPJ 05.704.744/0001-00
Fone: +55 (51) 3019-0500
info@fueltech.com.br
www.FuelTech.com.br

EUROPE

FuelTech Europe B.V.
Amsterdam, Netherlands
sales@fueltecheurope.com
+31203698181



FOLLOW US

