

**FuelTech**

**FT 700**

**VISION FT**



**OWNER'S  
MANUAL**

## 1. Index

2.	Presentation .....	6
3.	Warranty terms .....	7
4.	Specifications .....	10
4.1	Harness connections A connector .....	12
4.2	Harness connections B connector .....	14
4.3	Harness connections C (Optional) .....	16
4.4	Harness connections D (Optional) .....	18
4.5	Harness connections M (optional) .....	20
4.6	PowerShift Connector .....	21
4.7	Auxiliary outputs .....	21
4.8	Internal MAP sensor .....	21
4.9	USB port .....	21
4.10	FuelTech CAN network .....	22
4.11	Connector disassembly .....	22
5.	Before installation .....	24
6.	Interface and operation .....	26
6.1	VCU interface 7", 12", tablet and mobile .....	26
6.2	FuelTech Vision software interface (desktop) .....	30
6.3	Mobile interface .....	33
6.4	Gestures .....	35
6.5	Hot Keys .....	35
6.6	Connectivity .....	36
6.7	FT700 disassembly .....	37
6.8	FT700Plus disassembly .....	38
7.	Engine settings .....	40
7.1	Engine setup .....	40
7.2	RPM signal .....	43
7.3	Cam sync sensor .....	46
7.4	Ignition .....	47
7.5	Fuel injection .....	50
7.6	Pedal/Throttle .....	52
7.7	Idle actuators .....	54
7.8	Fuel configuration .....	55
7.9	Injector Configuration .....	55
8.	Electrical installation .....	58
9.	Wiring PowerFT ECUs to harnesses from previous ECUs .....	62
9.1	Diagram Connector - FT450 to FT700 .....	62
9.2	Diagram Connector - FT550 (Connector A) to FT700 .....	64
9.3	Diagram Connector - FT550 (Connector B) to FT700 .....	65
10.	Fuel injectors .....	68
11.	Ignition .....	68
12.	Sensors and actuators .....	70
12.1	Intake air temperature sensor .....	70
12.2	Engine temperature sensor .....	70
12.3	Fuel and oil pressure .....	71
12.4	Throttle position sensor (TPS) .....	71
12.5	Crank trigger/RPM sensor .....	72
12.6	Camshaft position sensor .....	74
12.7	O2 sensor .....	74
12.8	Step motor – idle speed .....	74
13.	Auxiliary outputs .....	75
13.1	Cooling fan 1 and 2 .....	75
13.2	Idle valve .....	75
13.3	Air conditioning .....	75
13.4	Shift Alert .....	76
13.5	Fuel pump .....	76
13.6	Variable camshaft control/Powerglide gearbox .....	76
13.7	Progressive nitrous control .....	76
13.8	Boost Control – N75 .....	77
13.9	BoostController .....	77
14.	Electronic throttle control .....	78
14.1	Electronic throttle control .....	78
14.2	Connection – throttle bodies and pedals .....	78
15.	Inputs/outputs and calibrations .....	80
15.1	TPS calibration .....	80
15.2	Electronic throttle/pedal calibration .....	81
15.3	Ignition calibration .....	82
15.4	Calibrating eGate #1 and #2 Position .....	83
15.5	Fuel/oil pressure sensors inputs .....	84
15.6	Intake air and engine temperature sensors .....	85
15.7	O2 sensor inputs .....	86
15.8	Wheel speed .....	87
15.9	Drive shaft RPM .....	88
15.10	Input shaft RPM .....	88
15.11	MAP Sensor .....	89
15.12	Gear detection .....	89
15.13	Nitrous bottle pressure .....	91
15.14	Clutch .....	92
15.15	Height .....	92
15.16	Pitch .....	92
15.17	EGT .....	93
15.18	Wastegate Pressure .....	93
15.19	Internal accelerometer .....	94
15.20	Shocks .....	95
15.21	Flex Fuel .....	96
15.22	Backpressure .....	96
15.23	Pan vacuum .....	96

15.24	Transmission pressure .....	97	18.12	Acceleration fuel enrichment and decay .....	130
15.25	Transmission temperature .....	97	18.13	Engine temperature compensation .....	131
15.26	Torque converter pressure .....	97	18.14	Intake air temperature compensation .....	132
15.27	Intercooler temperature .....	98	18.15	Battery voltage compensation .....	132
15.28	Wheel temperature .....	98	18.16	MAP / TPS compensation .....	133
15.29	Track temperature .....	98	18.17	Prime pulse .....	133
15.30	Water pressure .....	99	18.18	Engine start .....	134
15.31	Turn signals .....	99	18.19	Post-start enrichment .....	134
15.32	Low beam / High beam .....	99	18.20	Individual cylinder trim .....	134
15.33	Turbo speed RPM .....	100	18.21	Gear compensation .....	135
15.34	Fuel flow .....	100	18.22	Gear change compensation .....	135
15.35	Flywheel RPM (Clutch basket) .....	101	18.23	Fuel injection angle table .....	136
15.36	Battery temperature .....	101	19.	Ignition tables adjust .....	138
15.37	Automatic transmission range selector .....	101	19.1	Main ignition map .....	138
15.38	Paddle Shift .....	103	19.2	Overall ignition trim .....	138
15.39	Brake .....	103	19.3	MAP/TPS compensation .....	139
15.40	Compressed air pressure .....	103	19.4	Intake air temperature compensation .....	139
15.41	Internal lambda probe conditioner 1 and 2 .....	104	19.5	Engine temperature compensation .....	140
15.42	Brake disc temperature .....	104	19.6	Individual cylinder trim .....	140
15.43	BlowOff Position .....	105	19.7	Timing limits .....	141
15.44	Fuel consumption control .....	105	19.8	Engine Start .....	141
15.45	Fuel level .....	106	19.9	Gear based compensation .....	142
15.46	Blow by pressure .....	106	19.10	Gear shift compensation .....	142
15.47	Strain Gauge .....	107	20.	Other Functions .....	144
15.48	VR inputs .....	107	20.1	Idle speed control .....	144
15.49	Sensors VE .....	108	20.2	Deceleration cut-off .....	148
16.	Datalogger .....	110	20.3	Rev limiter .....	149
16.1	VCU Logs .....	110	20.4	Shift Light .....	150
16.2	Cloud Log .....	110	20.5	Thermatic Fan #1 .....	150
16.3	Channels .....	111	20.6	Thermatic fan #2 .....	152
16.4	Settings .....	112	20.7	Air conditioning .....	153
16.5	Log interface .....	113	20.8	Fuel pump .....	154
17.	Datalogger in VisionFT Software .....	114	20.9	Cold start auxiliary .....	155
17.1	Opening a log .....	114	20.10	Variable control (VTEC) .....	156
17.2	Settings .....	115	20.11	Progressive Nitrous control .....	157
17.3	Charts .....	117	20.12	Generic duty cycle control .....	160
18.	Fuel tables adjust .....	119	20.13	Boost activated output #1 and #2 .....	161
18.1	Main MAP VE table (Volumetric Efficiency) .....	119	20.14	Tach Output .....	162
18.2	Fuel target tables .....	120	20.15	Wastegate Boost Control #1 and #2 .....	162
18.3	Exhaust / baro pressure compensation .....	122	20.16	Start button .....	167
18.4	Injector staging .....	122	20.17	RPM activated output .....	168
18.5	O2 close loop target table .....	123	20.18	Map selection by button .....	169
18.6	AFR Target Map .....	123	20.19	Pit Limit .....	170
18.7	Main fuel table .....	124	20.20	Active Traction Control .....	170
18.8	Overall fuel trim .....	125	20.21	Generic output .....	173
18.9	RPM compensation .....	125	20.22	Flex fuel .....	173
18.10	O2 Closed Loop .....	126	20.23	Blip / Heel and Toe .....	174
18.11	Idle speed by TPS table .....	130	20.24	Variable camshaft (VVT) .....	175
			20.25	Automatic transmission control .....	177

20.26 Lockup Control .....	179	25.3 Wi-fi .....	237
20.27 Push to pass (P2P) .....	181	25.4 Connection with USB network adapter .....	238
20.28 DRS .....	182	25.5 USB .....	238
20.29 DRL .....	183	25.6 Passwords and permissions .....	239
20.30 Fan Push .....	183	25.7 Single identifiers .....	239
20.31 Anti-lag / Pops & Bangs / Engine brake .....	184	25.8 Identification information .....	240
20.32 Gear control Management .....	186	25.9 Serial Number and Version .....	240
20.33 Compressed air control .....	189	25.10 Map options .....	241
20.34 Electronic wastegate control .....	190	25.11 CAN Ports .....	242
20.35 Boost control by ETC position .....	192	25.12 Customizable CAN .....	243
20.36 Control by external reference .....	193	25.13 CAN Custom Packages .....	244
20.37 Timed main relay .....	193	25.14 SwitchPanel .....	244
20.38 Electronic Blow Off control .....	194	25.15 EGT-4 .....	245
20.39 Brake bias .....	195	25.16 Racelink .....	246
		25.17 Steering wheel .....	246
21. Drag race features .....	197	25.18 IP cameras .....	247
21.1 Burnout mode .....	197	25.19 Analog camera .....	247
21.2 3-step (boost spool) .....	198	25.20 Advanced map settings .....	248
21.3 2-step rev limiter .....	199	25.21 Yellow outputs .....	248
21.4 Launch delay control (delay box) .....	203		
21.5 Brake line lock control .....	204	26. EV Settings .....	250
21.6 Timing table for rev launch .....	205	26.1 Glossary .....	250
21.7 Gear shift output .....	206	26.2 Powertrain .....	250
21.8 Time based compensations .....	207	26.3 EV output configuration .....	252
21.9 Pro-Nitrous .....	210	26.4 Battery .....	252
21.10 Time based output .....	214	26.5 DCDC Converter .....	253
21.11 Wheelie control .....	214	26.6 Driving assistances .....	254
21.12 Staging control / Transbrake .....	216	26.7 Charging Control .....	255
21.13 Mechanical fuel injection controller (MFI) .....	217	26.8 Torque and Regen .....	256
21.14 Time based individual fuel trim .....	219		
21.15 Time based individual ignition trim .....	219	27. Custom function .....	257
22. Alerts Settings .....	221		
22.1 General configuration of alerts (Safe mode) .....	221		
23. File Manager .....	224		
24. Interface settings .....	226		
24.1 Day/night mode .....	226		
24.2 LCD settings .....	226		
24.3 LED configuration .....	226		
24.4 Sound settings .....	228		
24.5 Dashboard setup .....	228		
24.6 Startup screen selection .....	231		
24.7 Measurement units .....	231		
24.8 Language .....	232		
24.9 Theme selection (VisionFT software) .....	232		
25. VCU Settings .....	234		
25.1 Inputs .....	234		
25.2 Outputs .....	236		

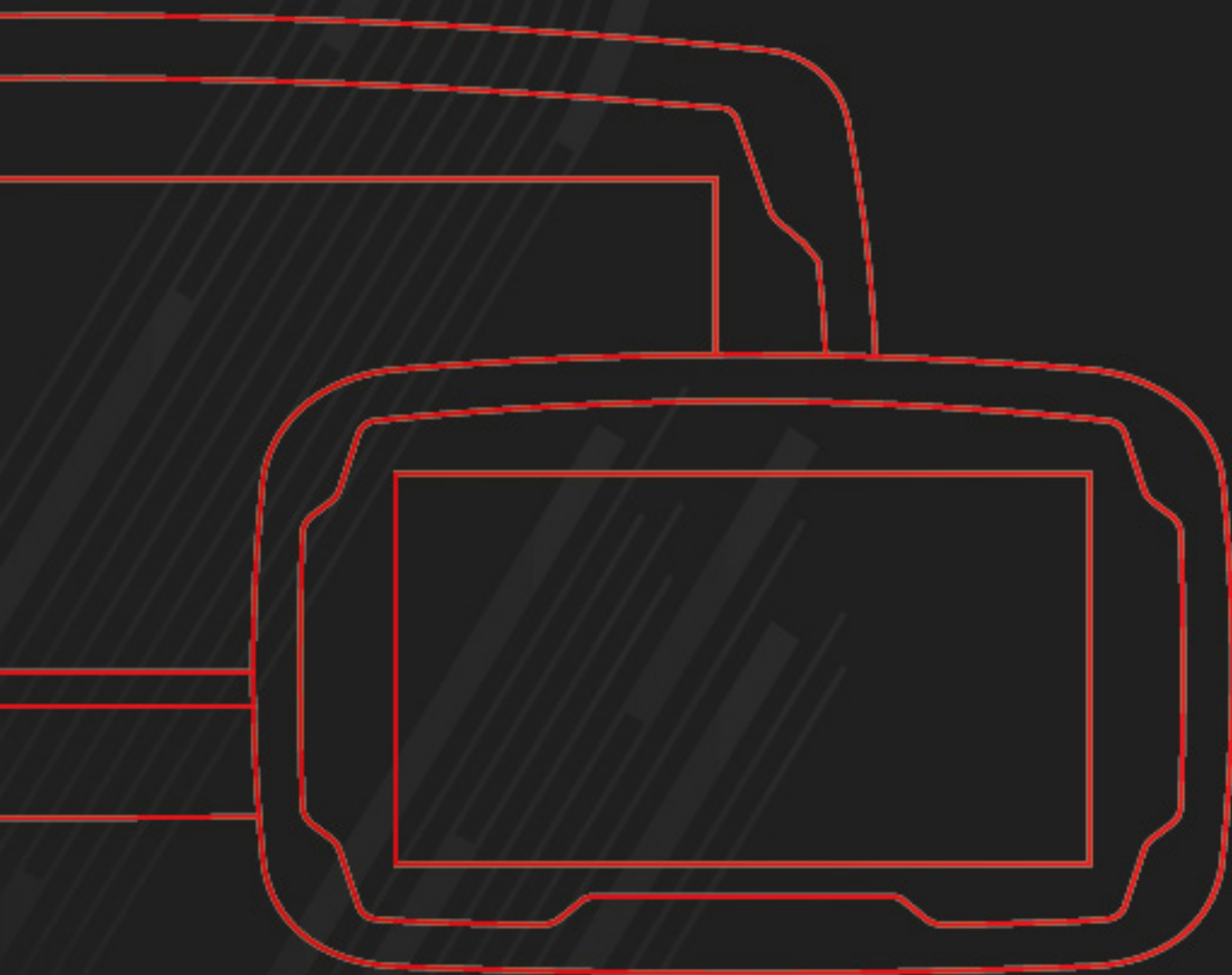

# ***PRESENTATION***



## 2. Presentation

Congratulations! Now you are part of FuelTech's high-performance world! The equipment you are receiving is the most advanced in automotive electronics management for performance.

We at FuelTech hope you have many victories and have fun along the way, because winning is in our DNA!

The FT700 and FT700Plus are part of VisionFT, FuelTech's new product line, FuelTech new VCU line, as they increasingly control other vehicle systems in addition to complete engine management. These VCUs have all the features already known from the renowned PowerFT line and are completely plug and play when installing from an FT600, that is, simply disconnect connectors A and B from the FT600 and connect the FT700, transfer the map and start the engine.

The FT700 has a 7-inch high-definition touchscreen, with 32 inputs divided by colors for reading various information such as frequency, wheel speeds, audio, video, pressure, position, among others.

There are 50 configurable outputs divided by colors (blue, gray and yellow). An exclusive connector for connecting video cameras in sync with the log, very useful for analyzing logs in various segments of motor sports.

It now has 4 CAN networks, one dedicated to FuelTech (FTCAN 2.0) and another 3 that can be configured according to the vehicle's design. Two USB Type-C ports (one rear and one front) and also a built-in speaker on the front.

This VCU has two O2 conditioners integrated into its hardware, fully compatible with Bosch LSU 4.2, 4.9, 5.2 and NTK sensors.

And for those looking for a bigger dash, we have the FT700Plus which has a 12-inch ultra-wide screen.

### 3. Warranty terms

The use of this equipment implies the total accordance with the terms described in this manual and exempts the manufacturer from any responsibility regarding to product misuse

Read all the information in this manual before starting the product installation.

#### NOTES

*This product must be installed and tuned by specialized auto shops and/or personnel with experience on engine tuning.*

Before starting any electric installation, disconnect the battery.

The inobservance of any of the warnings or precautions described in this manual might cause engine damage and lead to the invalidation of this product warranty. The improper use of the product might cause engine damage.

This product does not have a certification for the use on aircraft or any flying devices, as it has not been designed for such use purpose.

In some countries where an annual inspection of vehicles is enforced, no modification in the OEM ECU is permitted. Be informed about local laws and regulations prior to the product installation.

#### Important warnings for proper installation of this product:

- Always cut/remove the unused parts of the wiring harness NEVER roll up the excess, if not it greatly increases the chance of EMI interference.
- The solid black wire ECU ground of the harness MUST be connected directly to the battery's negative terminal.
- It is also recommended to wire the black/white power ground wires directly to the battery negative terminal, but they must run separately of the solid black ECU ground wire until the battery terminal. If the ECU has improper grounding, it may cause major irreparable damage to the unit.

#### IMPORTANT

*The all black and black/white ground wires must go SEPARATELY to the negative battery terminal.*

#### WARNING

*- It is recommended to save the maps on your computer as a safety backup. If your unit has an issue, this will guarantee having the correct setup saved. In some cases, when sent to the factory, your module may have its memory reset, requiring its last backup to return to correct operation.*

*- Periodically check our website ([www.fueltech.net](http://www.fueltech.net)) and use all the new resources available from VCU and the VisionFT software. Download to your computer, smartphone, tablet or directly on your VCU.*

#### IMPORTANT

*The VisionFT VCUs modules are water resistant, as long as some specific precautions are taken:*

*- Do not direct water jets directly onto the screen.*

*- When removing the wires from the connector, put plugs in place. (Part number 5011100683)*

## Limited Warranty

This product warranty is limited to three years from the date of purchase and covers only manufacturing defects upon presentation of purchase invoice.

This VCU has a serial number that's linked to the purchase invoice and to the warranty. In case of product exchange, please contact FuelTech tech support.

Damages caused by misuse of the unit are not covered by the warranty. This analysis is done by FuelTech tech support team.

The violation of the warranty seal results in the invalidation of the Product Warranty.

***All VisionFT VCUs are protected by US Patent 11,215,158***

Manual Version 1.0 – October/2025

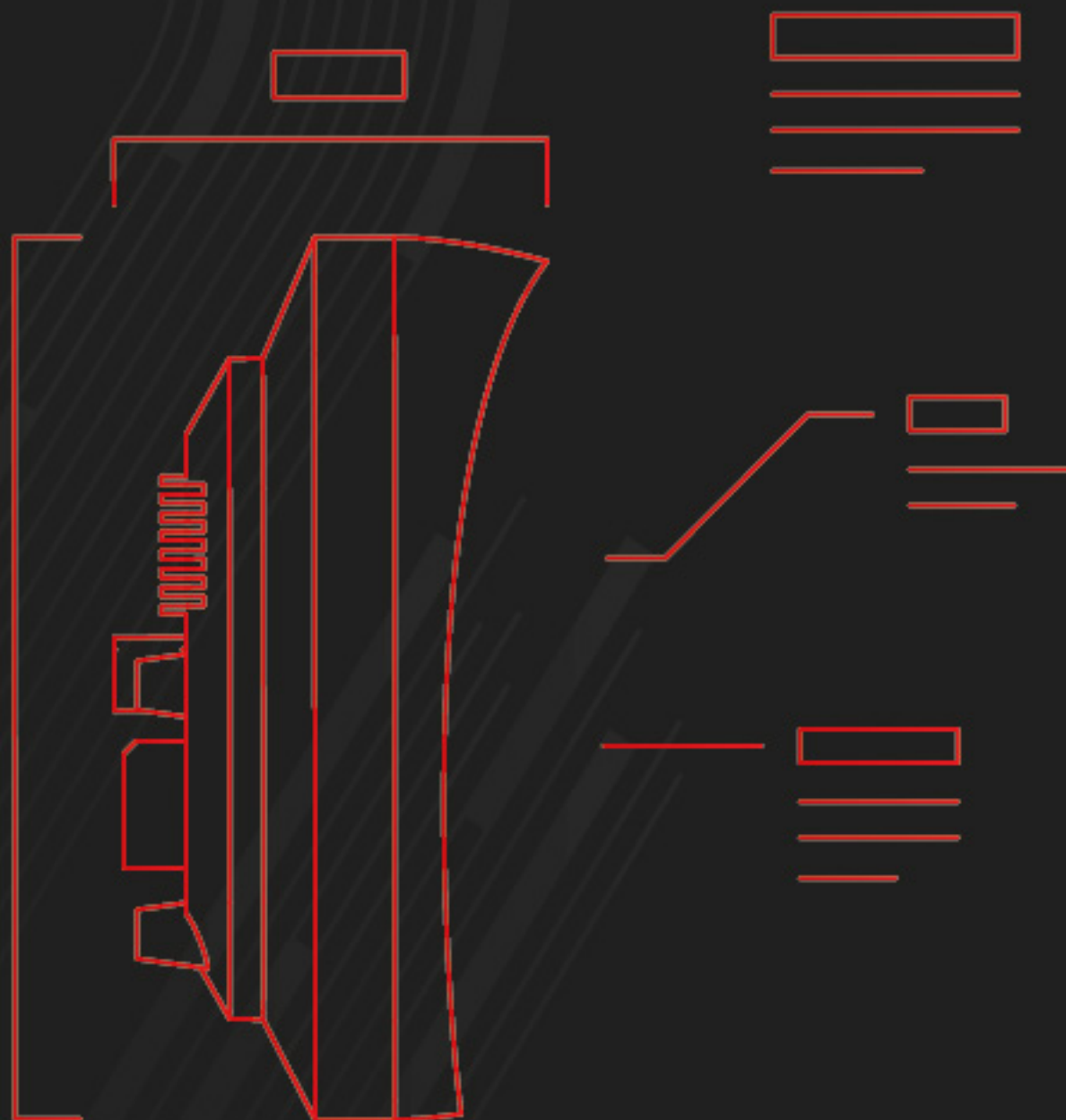

# ***ESPECIFICACIONES***

## 4. Specifications

- OTTO cycle engine control up to 16 cylinders
- Wankel engines control up to 6 rotors
- 3 modes of fuel control (sequential, semi sequential and multi-point)
- 2 modes of ignition control (wasted spark, sequential and distributor)
- Injection control by volumetric efficiency (VE)
- Electronic throttle body Control (Drive-By-Wire)
- 3 modes idle speed control (by PWM valve, by electronic throttle, by stepper motor and ignition timing)
- Closed loop injection through oxygen sensor (wide band lambda sensor)
- Real time programmable by dashboard, smartphone, tablet or VisionFT software
  
- 2 inputs dedicated for Crank and CAM signal
- 26 inputs channels totally configurable - digital and analog (2 high sensitivity inputs designed for strain gauge shifter)<sup>8</sup>
- 8 input channels high speed (pink)<sup>4</sup>
- Accelerometer, gyroscope and GPS (integrated)
- 103psi internal MAP sensor (7 bar - absolute), 14.7psi of vacuum and 88psi of positive pressure (boost)
- 2 USB Type-C ports, one on the front and one on the back<sup>7</sup>
- Communication port with automotive Ethernet- 4 CANs, (3-CAN FD)
  
- 50 configurable outputs separated by colors (16 blue<sup>1</sup>), (12 gray<sup>2</sup>) and (22 yellow<sup>3 5</sup>)
- 4 multimedia outputs (audio and video)
  
- Sequential injection control for up to 3 banks (A, B and C) (with 16 injectors in each)
- Main injection map by MAP or TPS by RPM (3D) with injection time resolution of 0.001ms
- Fuel enrichment and decay adjust, Individual cylinder trim setting by MAP or RPM
  
- Sequential ignition control for up to 16 cylinders (12 gray outputs + 4 yellow outputs)
- Main ignition map by MAP or TPS by RPM (3D) with ignition angle resolution of 0.1°
- Ignition timing compensation by (air temperature, engine, gear and gear changes)
  
- Many warning parameters such as: rev limiter, fuel cut-off, ignition cut-off, shift light on the screen and externally, audible signals, among others
  
- Dashboard with customizable instrument panel with gauges of different sizes and styles that can be used with any sensor present on the VCU
- Upper bar with 12 RGB LEDs to display RPM with configurable colors and values
- 8 RGB LEDs side lights which can be triggered by 3 different combined settings
- Diagnosis dashboard with real-time information of all inputs outputs, CAN and Status Events
  
- 1024 log recording channels
- 64 GB of internal memory
- 1kHz recording rate
- 617 hours of Data storage for up to<sup>6</sup>

1 - Recommended for high impedance injectors without the need for an external driver (up to 4 injectors per output)

2 - Recommended for ignition (open collector outputs with 5V power supply)

3 - Recommended for driving stepper motors, electronic throttles, ignition and 12V loads.

4 - Used for high-speed sensors (400khz per channel)

5 - The green outputs, when not used to power the integrated Lambda Sensor, can be used as yellow outputs.

6 - Recording time measured on the FT700 with 24 channels and 25Hz.

7 - Rear port only for connection with flash drive, external HD or 5G modem, does not support connection with computers.

8 - Inputs #1 to #11 can be configured with the SENT protocol.

- Working temperature: -20 to 70 °C
- Maximum power voltage: 30V

#### Dimensions (in) - (W x H x D)

- FT700 VCU: 8.62 x 5.43 x 3.11
- FT700 PLUS VCU: 14.4 x 7.09 x 3.48
- Box: 12.95 x 19.41 x 6.69

#### Weight (oz)

- FT700 VCU: **45.15**
- FT700 PLUS VCU: **64.9**

#### 4.1 Harness connections A connector

Pin	Wire Color	Function	Information
01	Blue#01	Blue output #01	These outputs are usually used for injector control. When needed, they can be configured as auxiliary outputs.
02	Blue#02	Blue output #02	
03	Blue#03	Blue output #03	
04	Blue#04	Blue output #04	
05	Blue#05	Blue output #05	
06	Blue#06	Blue output #06	
07	Blue#07	Blue output #07	
08	Blue#08	Blue output #08	
09	Blue#09	Blue output #09	
10	Blue#10	Blue output #10	
11	Blue#11	Blue output #11	
12	Blue#12	Blue output #12	
13	Blue#13	Blue output #13	
14	Blue#14	Blue output #14	
15	Blue#15	Blue output #15	
16	Blue#16	Blue output #16	
17	Black/White	Power ground	<b>Directly</b> wired to the battery negative terminal with no seams. Do not tap any other grounds to this wire, it must run clean straight to the battery negative terminal.
18	Gray#01	Gray output#01	These outputs are usually used for ignition control. When needed, they can be set up as injector outputs (Peak and Hold driver required) By standard, Gray output #08 is used as a tachometer output.
19	Gray#02	Gray output#02	
20	Gray#03	Gray output#03	
21	Gray#04	Gray output#04	
22	Gray#05	Gray output#05	
23	Gray#06	Gray output#06	
24	Gray#07	Gray output#07	
25	Gray#08	Gray output#08	
26	Yellow#01	Yellow output#01	Electronic throttle and step motor outputs. Also used as injection or auxiliary outputs (cooling fan, fuel pump, etc.)
27	Yellow#02	Yellow output#02	
28	Yellow#03	Yellow output#03	
29	Yellow#04	Yellow output#04	
30	Yellow#05	Yellow output#05	
31	Yellow#06	Yellow output#06	
32	Yellow#07	Yellow output#07	
33	Yellow#08	Yellow output#08	
34	Red	12V input from relay	Connected to the pin 87 of the Main Relay.

### A-connector diagram

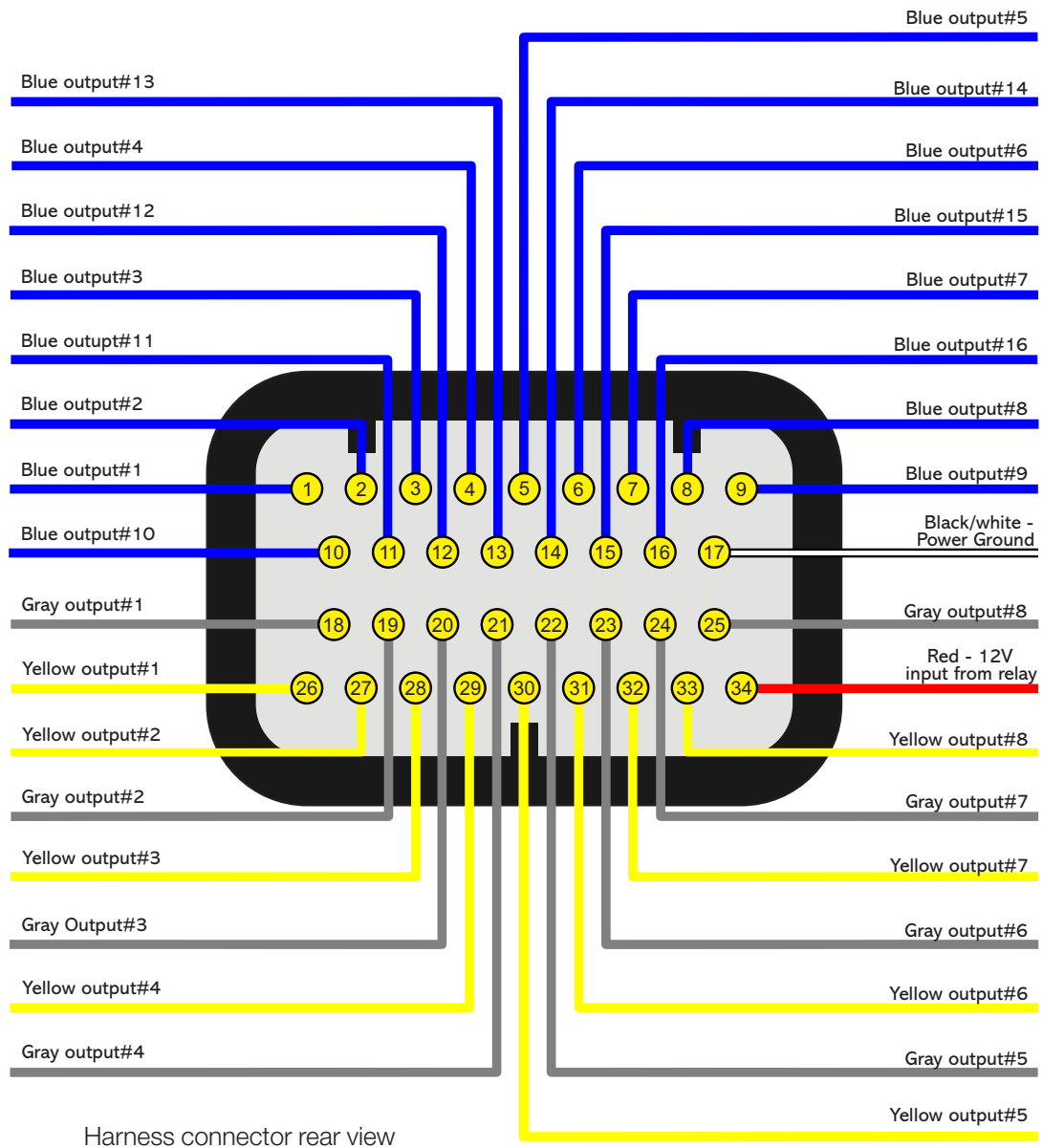

## 4.2 Harness connections B connector

Pin	Wire Color	Function	Information
01	Red	<b>RPM signal input</b>	Connected to the crank trigger sensor (hall or magnetic) or to the distributor.
02	White	Magnetic RPM sensor reference	Connected to the negative wire of the magnetic sensor, split the wire with OEM reference sensor - Do not connect when using hall effect sensor.
03	Red	Cam sync signal input	Connected to the cam sync sensor (hall or magnetic)
04	White	Cam sync reference input	Connected to the negative wire of the magnetic sensor. When OEM ECU is reading the sensor in parallel, split this wire with OEM sensor negative - Do not use the shield as negative to the sensor
05	White#01	White input#01 *	<b>Default:</b> O2 sensor input
06	White#02	White input#02 *	<b>Default:</b> two-step input
07	White#03	White input#03 *	<b>Default:</b> Air conditioning button
08	White#04	White input#04 *	<b>Default:</b> Oil pressure
09	White#05	White input#05 *	<b>Default:</b> Coolant temperature
10	Black	Battery negative	Connected directly to the battery negative with no seams. <b>Do not connect this wire to the chassis, engine block or head.</b>
11	Yellow/Blue	CAN A LOW	CAN A
12	White/Red	CAN A HIGH	
13	White#06	White input#06 *	<b>Default:</b> fuel pressure
14	White#07	White input#07 *	<b>Default:</b> Air temperature
15	White#08	White input#08 *	<b>Default:</b> pedal#2 signal input
16	White#09	White input#09 *	<b>Default:</b> pedal#1 signal input
17	White#10	White input#10 *	<b>Default:</b> MAP signal output, electronic throttle 1B input signal
18	Black/White	Power ground	<b>Directly</b> wired to the battery negative terminal with no seams. Do not tap any other grounds to this wire, it must run clean straight to the battery negative terminal.
19	Black/White		
20	White/Red	CAN B HIGH	CAN B HIGH
21	White#11	White input#11 *	<b>Default:</b> TPS sensor
22	White#12	White input#12	Generic sensor input
23	White#13	White input#13	
24	White#14	White input#14	
25	White#15	White input#15	
26	Red	12V input from relay	Connected to the pin 87 of the Main Relay
27	Green/Red	5V outputs for sensors	5V voltage output for TPS, electronic throttle and pedal sensors
28	Yellow/Blue	CAN B LOW	CAN B LOW
29	Green/Black	Ground for sensors	Connected the sensors ground
30	White#16	White input#16	Generic sensor input
31	White#17	White input#17	
32	White#18	White input#18	
33	White#19	White input#19	Strain gauge input - Blue wire Strain gage sensor (positive signal)
34	White#20	White input#20	Strain gauge input - Orange wire Strain gage sensor (negative signal)

\* Support SENT protocol

## B-connector diagram

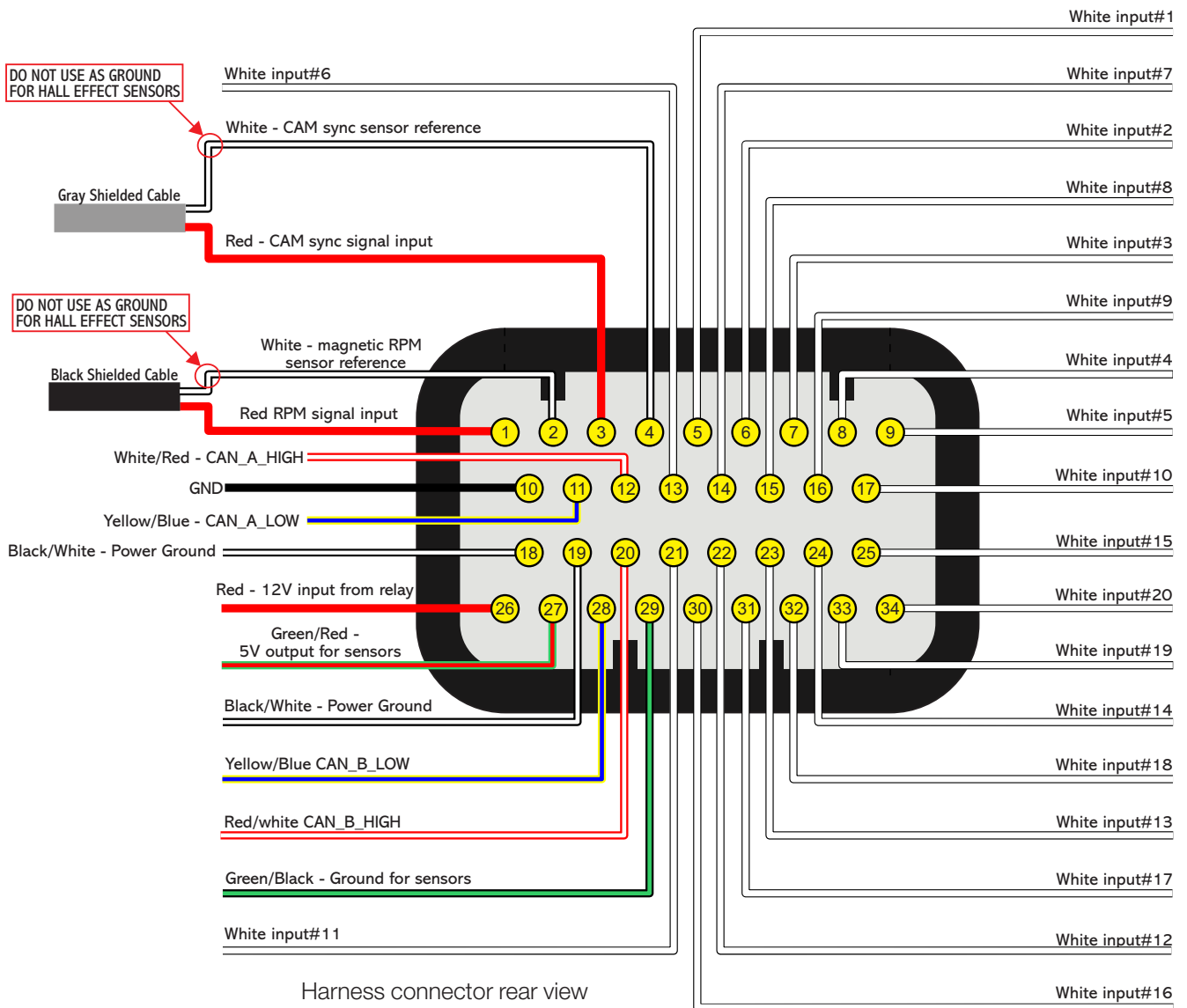

### NOTES

When using the Power Shift function connect the white wire from the shifter to ground for sensors Green/Black (pin #29).

### IMPORTANT

Fuel only: When using this option, the RPM signal input cannot be connected to a coil high voltage signal because the input has no protection and will damage the trigger input on the VCU. Please use a tach output, another rpm source or an ignition coil to tach adapter module to avoid damage to the unit.

### 4.3 Harness connections C (Optional)

Pin	Wire Color	Function	Information
01	Red	12V input from relay	Connected to the pin 87 of the Main Relay
02	Red		
03	Red		
04	Gray #09	Gray output #09	These outputs are usually used for ignition control. When needed, they can be set up as injector outputs or auxiliary outputs.
05	Gray #10	Gray output #10	
06	Gray #11	Gray output #11	
07	Gray #12	Gray output #12	
08	Yellow #09	Yellow output #09	Electronic throttle and step motor outputs. Also used as injection or auxiliary outputs (cooling fan, fuel pump, etc.)
09	Yellow #10	Yellow output #10	
10	Yellow #11	Yellow output #11	
11	Yellow #12	Yellow output #12	
12	Yellow #13	Yellow output #13	
13	Yellow #14	Yellow output #14	
14	Yellow #15	Yellow output #15	
15	Yellow #16	Yellow output #16	
16	Yellow #17	Yellow output #17	
17	Yellow #18	Yellow output #18	
18	White/Red	CAN C (+)	CAN C
19	Blue/Yellow	CAN C (-)	
20	Yellow #19	Yellow output #19	Electronic throttle and step motor outputs. Also used as injection or auxiliary outputs (cooling fan, fuel pump, etc.)
21	Yellow #20	Yellow output #20	
22	Green	Heat positive O2 sensor	Power supply for O2 sensor heaters 1 and 2***.
23	Green	Heat positive O2 sensor	
24	Black/White *	Power ground	<b>Directly</b> wired to the battery negative terminal with no seams. Do not tap any other grounds to this wire, it must run clean straight to the battery negative terminal.
25	Black/White *		
26	Black/White *		

\* Cable can be black

### IMPORTANT

\*\*\* If you do not use the integrated O2 sensor conditioner, these outputs can be used with two extra yellow outputs.

C-connector diagram (optional)

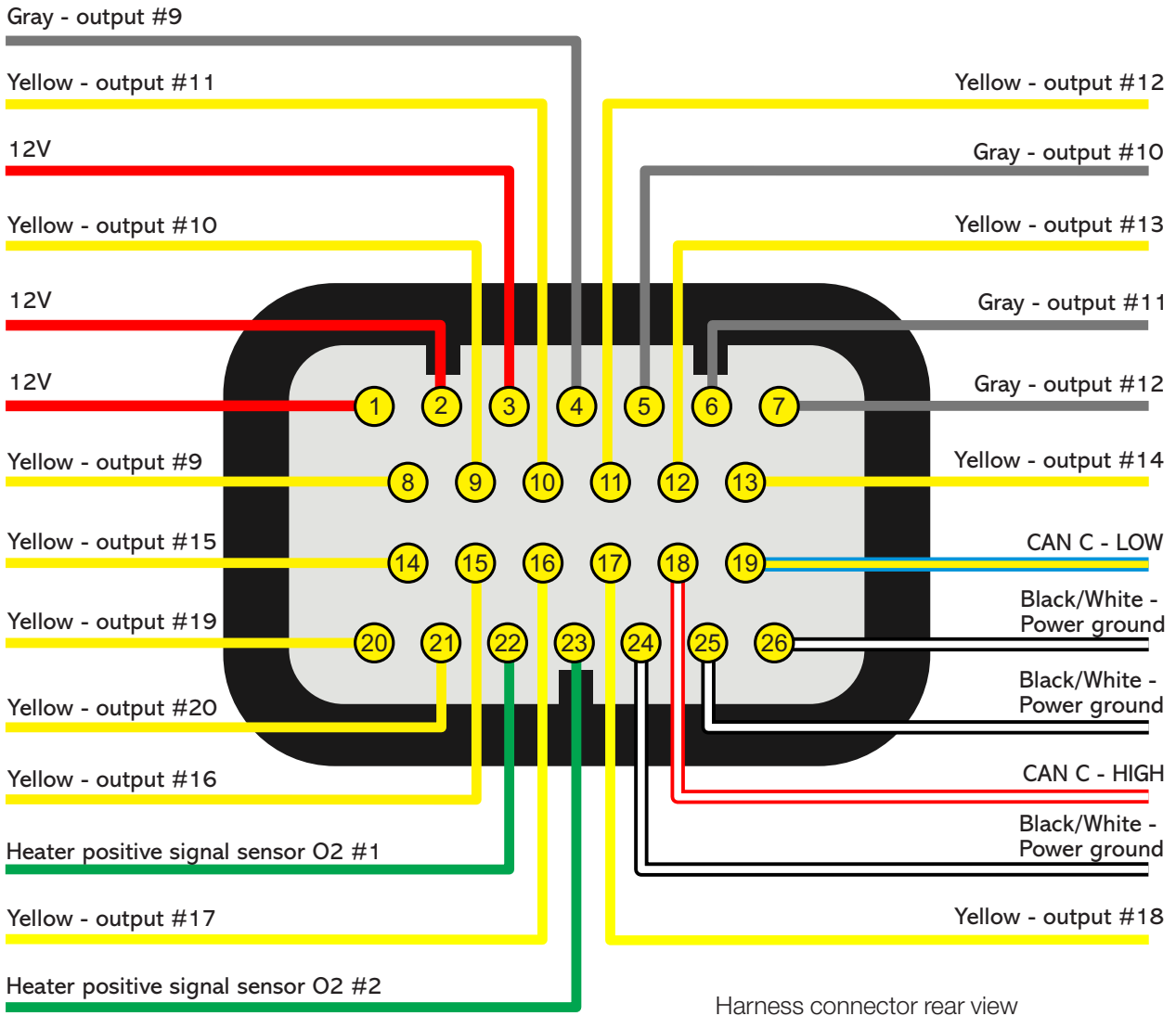

#### 4.4 Harness connections D (Optional)

Pin	Wire Color	Function	Information	Secondary function
01	Red	Input frequency channel #01	Shielded cable for reading RPM and speed signals - Frequency #01	Input #21
02	White			Input #22
03	Red	Input frequency channel #02	Shielded cable for reading RPM and speed signals - Frequency #02	Input #23
04	White			Input #24
05	Red	Input frequency channel #03	Shielded cable for reading RPM and speed signals - Frequency #03	Input #25
06	White			Input #26
07	Red	Input frequency channel #04	Shielded cable for reading RPM and speed signals - Frequency #04	Input #27
08	White			Input #28
09	Pink #01	Input for high speed reading #01	Used for high speed sensors (400khz per channel)	Input #29
10	Pink #02	Input for high speed reading #02		Input #30
11	Pink #03	Input for high speed reading #03		Input #31
12	Pink #04	Input for high speed reading #04		Input #32
13	Pink #05	Input for high speed reading #05		Input #33
14	Pink #06	Input for high speed reading #06		Input #34
15	Pink #07	Input for high speed reading #07		Input #35
16	Pink #08	Input for high speed reading #08		Input #36
17	Brown	Signal	Connected O2 sensor #1 NOTE: The Heat positive signal sensor is in connector C, green wire (pin 22)	-
18	Yellow	Ground		
19	Red	IP		
20	Orange	Resistor calibration		
21	Blue	Heater negative		
22	Brown	Signal	Connected O2 sensor #2 NOTE: The Heat positive signal sensor is in connector C, green wire (pin 23)	-
23	Yellow	Ground		
24	Red	IP		
25	Orange	Resistor calibration		
26	Blue	Heater negative		

### IMPORTANT

*Frequency and high speed inputs can be also configured as analog inputs.*

D-connector diagram (optional)

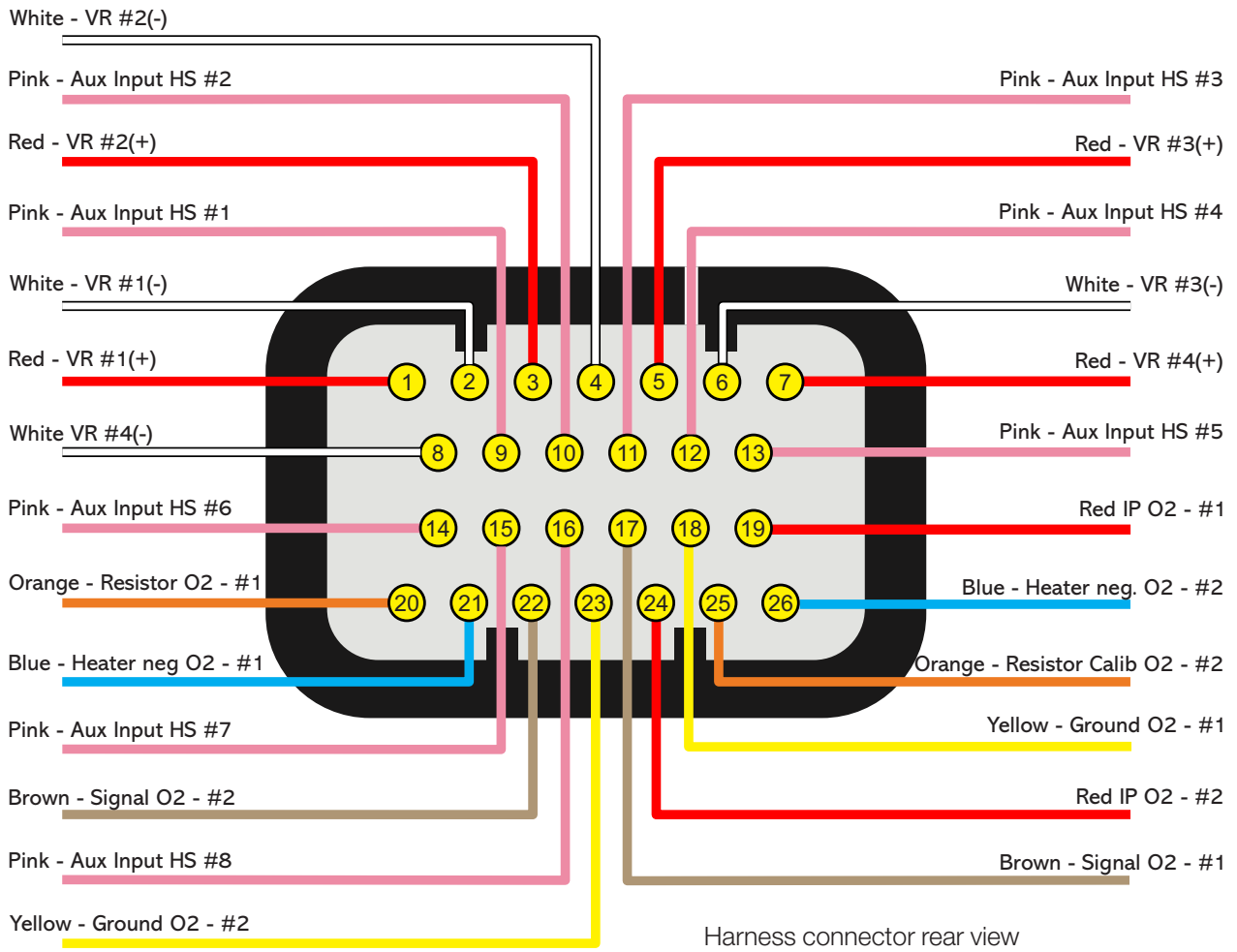

### 4.5 Harness connections M (optional)

Pin	Wire Color	Function	Information
01	Orange	ETH+ (Ethernet +)	Ethernet communication cable
02	White/Red	CAN D (+)	CAN D (+)
03	Black/White	AIR (right microphone input)	Shielded cable - signal
04	Black/White	AOR (right speaker)	Shielded cable - signal
05	Black	GND MIC (Ground microphone)	Shielded cable to left and right microphone
06	Black	GND VI2 (Ground video #2)	Use the shield as negative to video #2
07	Black/White	VI (video #2)	Shielded cable - signal
08	Green	ETH- (Ethernet -)	Ethernet communication cable
09	Yellow/blue	CAN D (-)	CAN D (-)
10	Black/White	AIL (left microphone input)	Shielded cable - signal
11	Black/White	AOL (Left Speaker)	Shielded cable - signal
12	Black	GND SPK (Ground speaker)	Shielded cable to left and right speaker
13	Black	GND VI1 (Ground video #1)	Use the shield as negative to video #2
14	Black/White	VI 1 (video #1)	Shielded cable - signal

### M-connector diagram (optional)

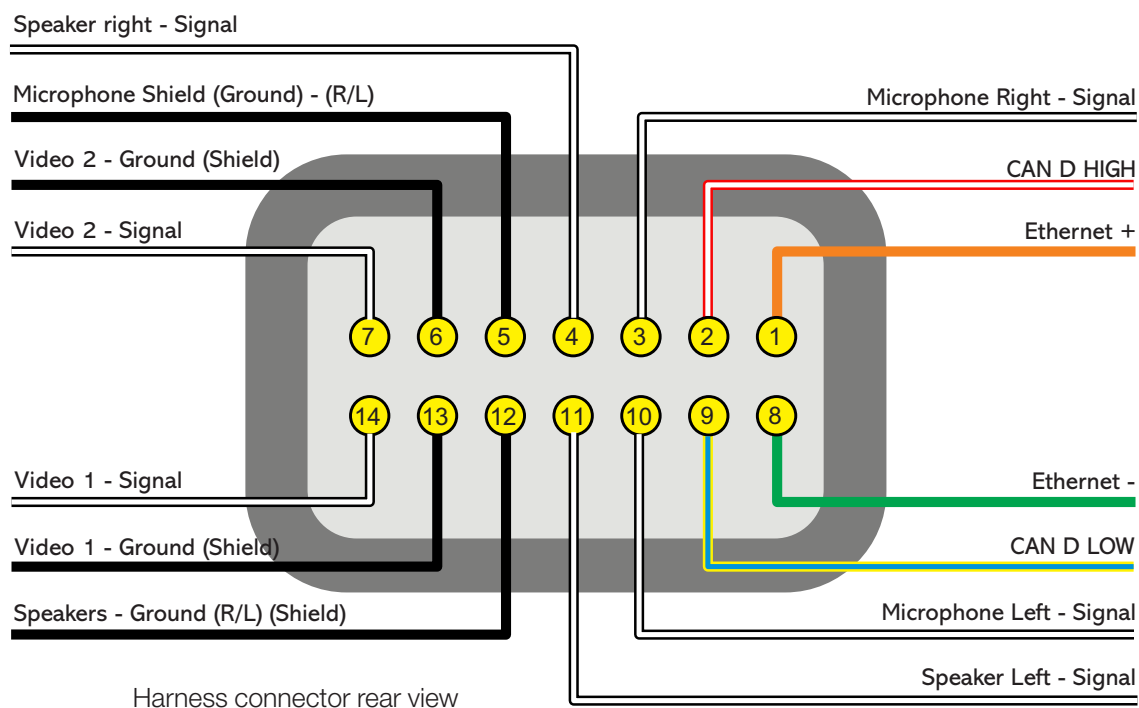

## 4.6 PowerShift Connector

The FT700 wiring harness comes with the gear strain gauge sensor connector. In case the vehicle isn't equipped with a gear strain gauge, this connector can be removed and its white inputs can be used for other functions.

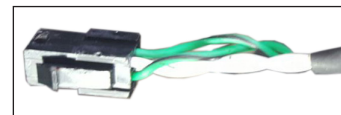

## 4.7 Auxiliary outputs

Outputs can be set up in many different ways, they have different capacities according to the function. Bellow is some important information about them:

**Blue outputs:** by default, used as injector outputs. Each one of them can control up to:

**Impedance higher than 10 Ohms:** 24 injectors (amongst all blue outputs)

**Impedance between 7 and 10 Ohms:** 16 injectors (amongst all blue outputs)

The use of a **Peak and Hold** driver is mandatory when the number of injectors is higher than the maximum quoted above or when using low impedance injectors (impedance below 7 Ohms).

During the Engine setup configuration, blue outputs will be selected automatically.

When more than 16 injector outputs are needed, the VCU will use Gray outputs or Yellow output. In this case, the use of a Peak and Hold driver is mandatory on Gray and Yellow outputs (for saturated and low impedance injectors).

Blue outputs not used to control fuel injectors may be used as auxiliary outputs (controlling fuel pump, cooling fan, etc.). In this case, the use of a relay is mandatory.

**Gray outputs:** by default, used as ignition outputs. According to the engine setup, they can be set up as injectors or auxiliary outputs.

During the Engine Setup configuration, ignition outputs will be selected automatically.

Gray outputs not used for ignition control can be set up as injectors outputs (the use of a Peak and Hold driver is mandatory) or as auxiliary outputs (the use of a relay is mandatory).

**Yellow outputs:** by default, they're used as electronic throttle control (Yellow #1 and #2) or stepper motor control (Yellow #1 to #4).

The yellow outputs that will not be used for electronic throttle control can be used as auxiliary outputs or for injectors. When using injectors for the integrated BoostController, the output can be connected directly to the injector, but when using injectors for fuel, the use of a Peak and Hold driver is mandatory for both high and low impedance injectors.

This is because this output may present minimal differences in the injection time when controlling fuel injectors without Peak and Hold.

**Tach output:** Gray output #8 is intended for the rev counter, however, if you need to use another output, you can use any yellow output.

## 4.8 Internal MAP sensor

This VCU is equipped with an internal MAP sensor. Use a 6mm pneumatic hose (4mm internal diameter) to connect the sensor to the intake manifold. Pneumatic hoses are flexible, durable and highly resistant. Usually found in black or blue colors.

Silicon hoses are not recommended because they can be easily bent, blocking vacuum/boost readings on the VCU MAP sensor.

Use a hose exclusively for FT MAP sensor, avoiding splitting it with valves, gauges, etc. Connect it to any spot between the throttle and the engine head. Its length must be as short as possible to avoid lags and errors on the sensor readings. When using individual throttle bodies, it is a good idea to connect all intake runners into a single point and then connect to the FT MAP sensor; otherwise, MAP readings may be erratic or inaccurate.

## 4.9 USB port

The USB cable is used to update the VCU firmware version, setup maps and adjusts trough a computer and VisionFT software and download data recorded by the internal datalogger.

### 4.10 FuelTech CAN network

FuelTech CAN port is a 4 way connector placed on the wiring harness of the VCU and is responsible for VCUs communication with other FT modules (GearController) and Racepak dashboards. A FuelTech CAN-CAN cable is used to establish a connection between them.

#### NOTES

The rear USB port was developed only for connecting an external modem, flash drive or external HD. To connect Laptops, it's necessary connect to the front USB port.

#### WARNING

For the correct operation of the CAN Network, its mandatory to use the CAN resistor as shown in the following image.

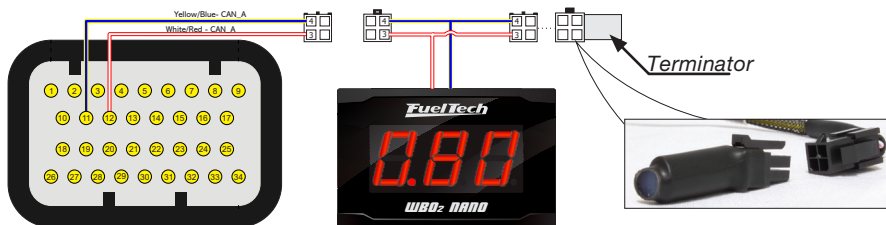

FuelTech unit connected to CAN network (WB-O2 NANO, Alcohol O2, EGT8, WB-O2 SLIM)

### 4.11 Connector disassembly

The connectors are built in a way that it's terminals can be easily taken out of the housing. To do so follow these instructions:

- a - Remove the connector from the VCU
- b - Push down the white lock (1)
- c - Pull the wire (2) out of the connector
- d - On the other side of the connector, push down the 2 small white locks (3)

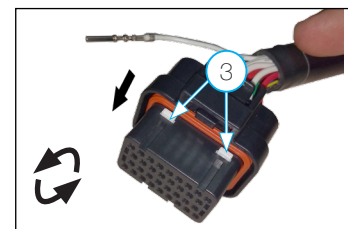
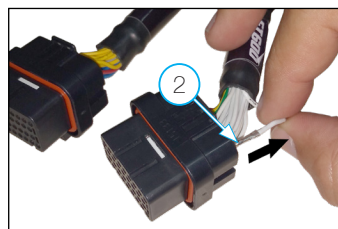
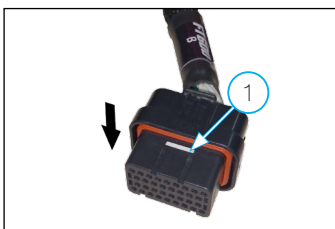

#### IMPORTANT

To ensure sealing of the module and electrical connector, do not remove any wires from the harness. The module seal is not affected, however the connector seal depends on the presence of wire and terminal inserted in its position. If you need to remove any wires, you must use a seal which can be sourced from Fuel-Tech, part number 5011100683.

Using the connector with a vacant and unsealed terminal may allow water to enter and cause oxidation on the VCU terminals and electrical connector.

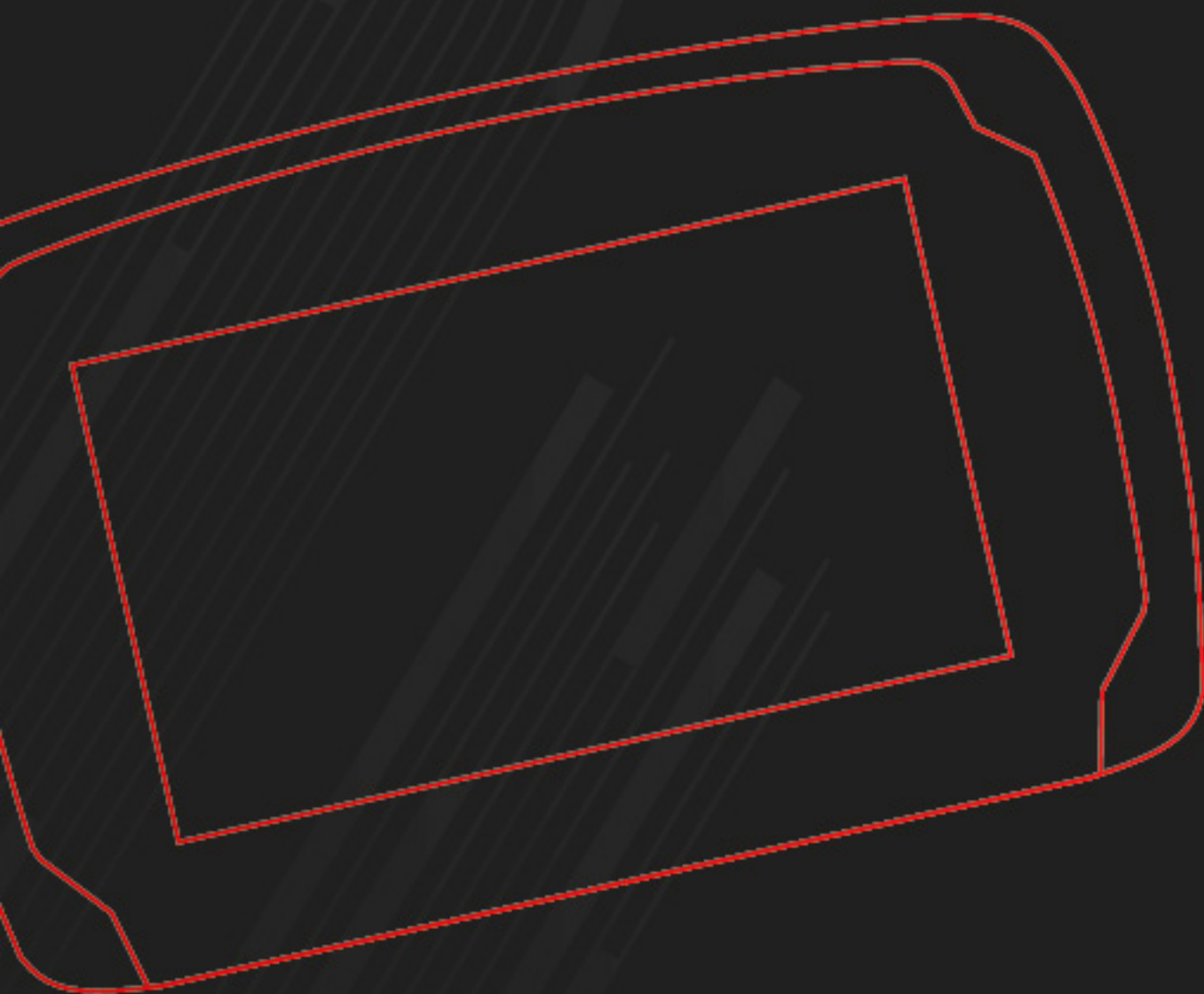

# ***FIRST STEPS***



## 5. Before installation

This is a step-by-step guide that must be followed to begin basic configurations and adjustments before starting your electrical installation. There is a feature in the software that automatically allocates the functions of the harness wires according to the engine characteristics (number of cylinders, fuel injection control mode, ignition coils and auxiliary outputs), however, a default assigned wire can also have its function modified by changing the settings to manual.

1. Install the VisionFT application on your smartphone, tablet or computer, connect to your VCU FT700 via bluetooth, wifi or USB cable and update the VCU to the latest version.
2. Run the Wizard to create the default map for the project.
3. Before starting the electrical installation, go to the “VCU settings”, in the last option, “Inputs and outputs” and check the way in which the functions were allocated to the harness wires, or even through the VisionFT Software, in the menu, view and print the pinout of the ECU connector with the function of each of the wires, according to the map configuration.

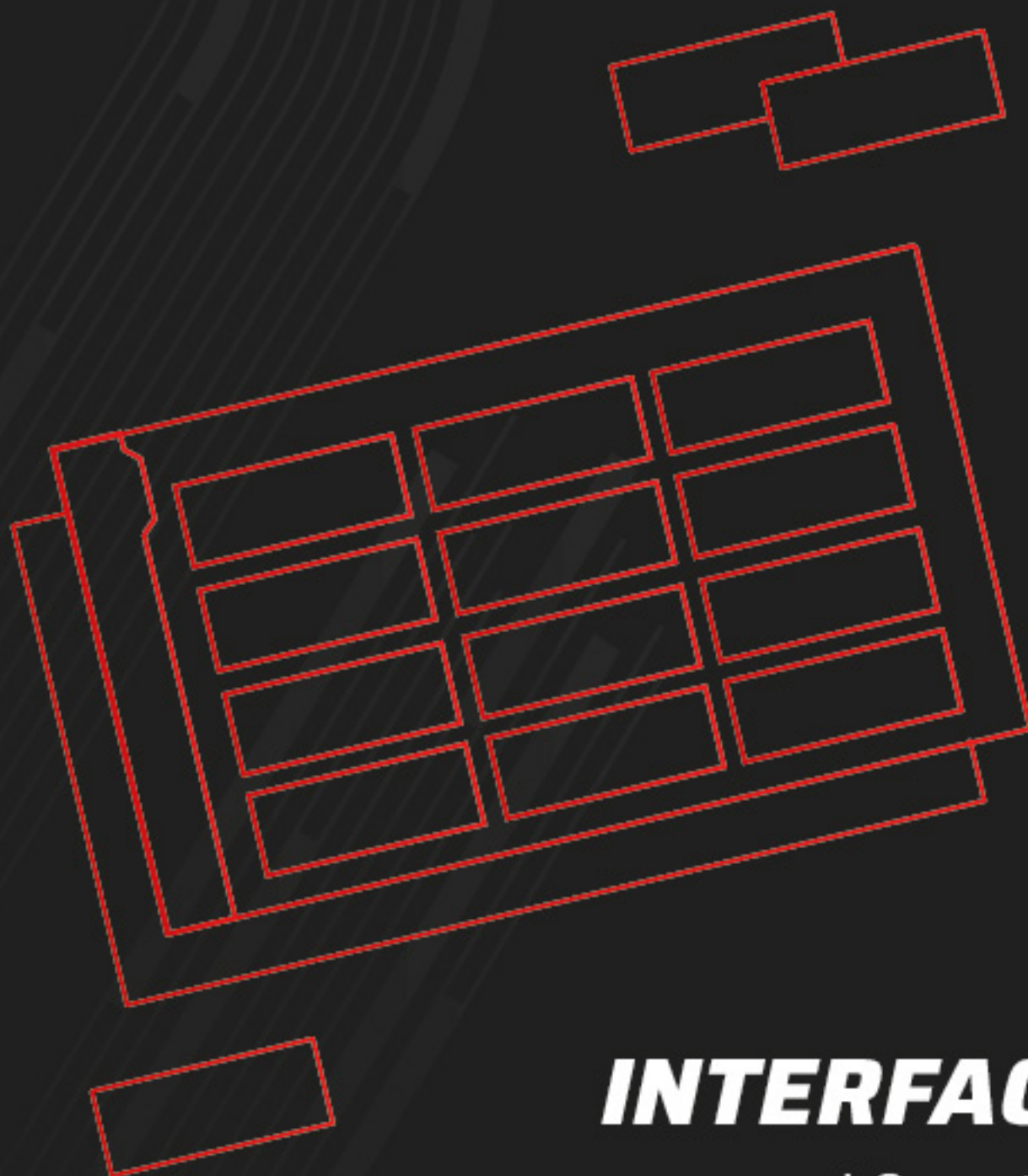

# ***INTERFACE***

and Operation



## 6. Interface and operation

A big difference between the PowerFT line and the new VisionFT line is the new more intuitive and smartphone-like interface. Another great advantage of the VisionFT line is that it is multi-platform, that is, it is practically the same interface between desktop software, VCU screen and smartphone application.

### 6.1 VCU interface 7”, 12”, tablet and mobile

There is a bar on the left side of the screen where navigation buttons between various VCU functions are located.

- 1 - **Function menu button:** this button opens the function groups.
- 2 - **Dashboard panel button:** show the configured instrument panel. You can configure up to four panels.
- 3 - **Recent button:** memorizes the last accessed functions.
- 4 - **Favorites button:** shows favorite functions
- 5 - **Alert Indicator:** This light turns on when there is an error code in the VCU
- 6 - **Reset required:** This light comes on when any engine settings are changed.
- 7 - **Connection Status:** In this option you can adjust the screen brightness, configure and turn on/off active connections on the VCU (Ethernet, Wi-fi, Bluetooth, FT Cloud), turn on/off log recording, lock the VCU, turn on/off night mode, turn on /turn off the vehicle, turn on/off real time and turn off the VCU screen.

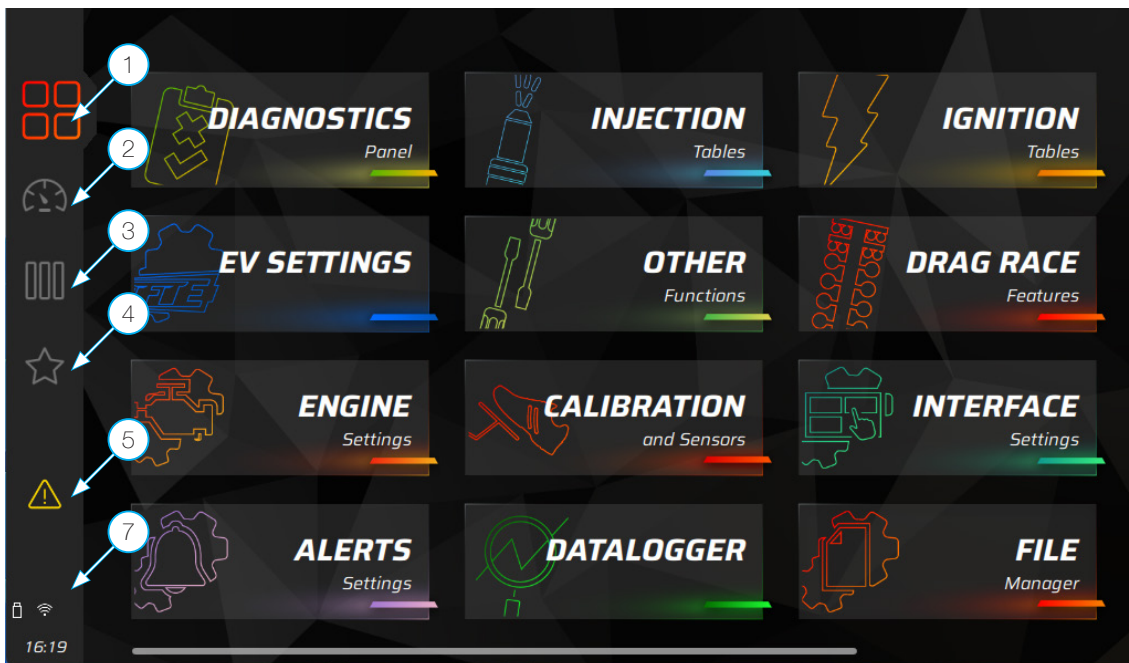

Main screen FT700 7 inch

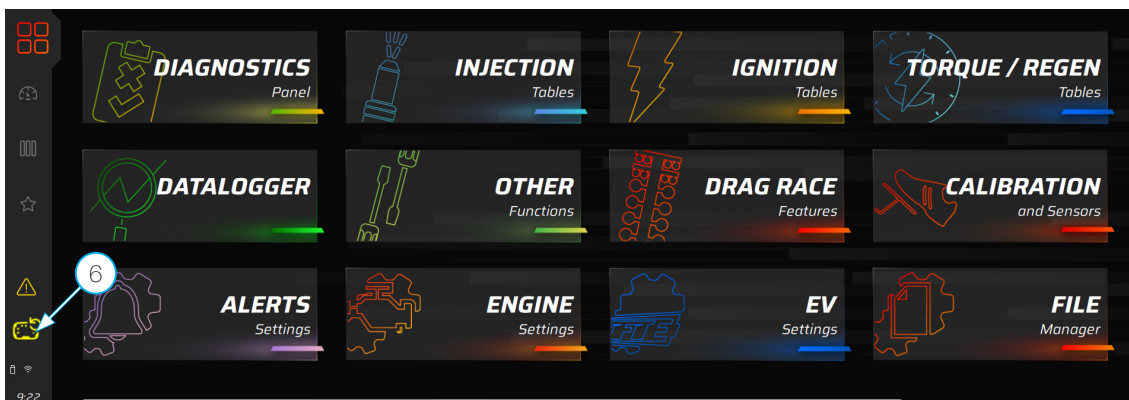

Main screen FT700 12 inch

Note in the image above that the button (1) is highlighted and colored, this indicates that it is active and showing the appropriate content.

### Function menu (1)

This menu concentrates all groups of functions available for configuring the VCU. The images below show active functions and disabled functions.

**Active functions:** appear highlighted and with a bar in the color of the selected group.

**Disabled functions:** appear less prominently and there is no bar on the function.

Button (8) is a filter, by clicking on it the disabled functions are hidden from view, leaving only the active functions.

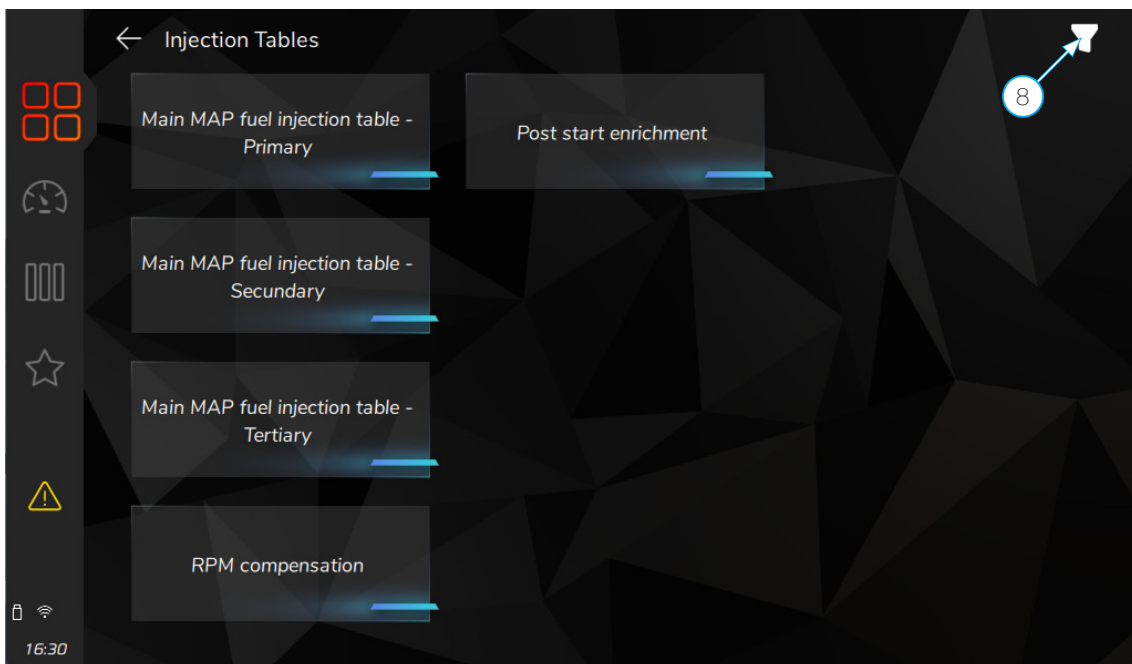
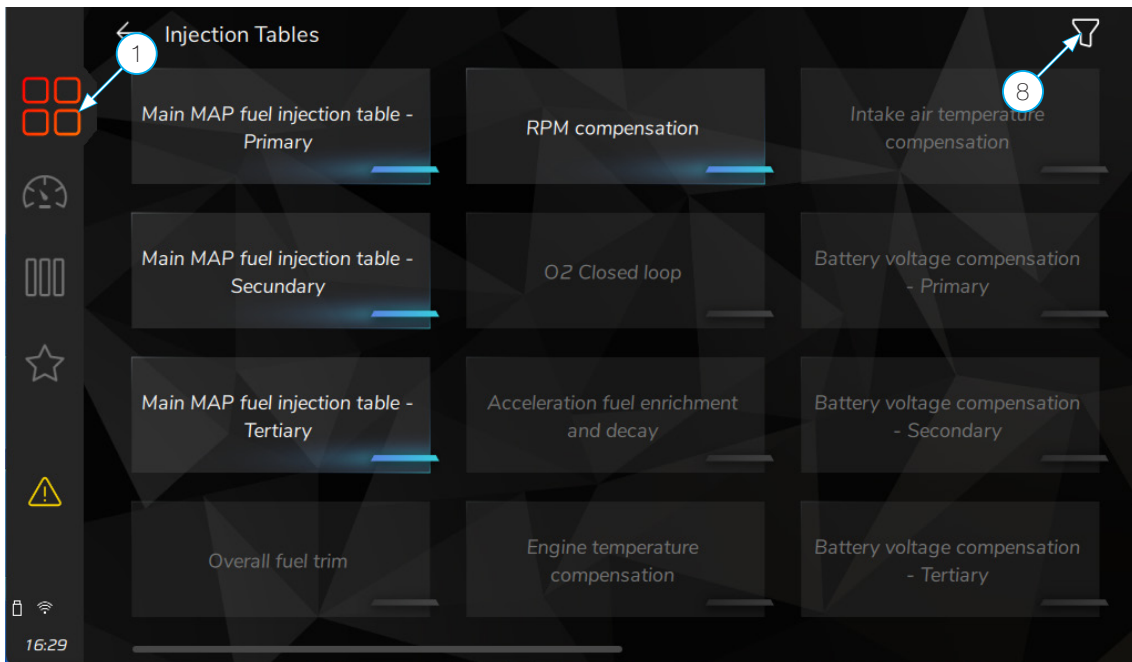

To activate a function, simply press and hold on the function you want to activate, then a menu will open with two other buttons.

9 - **On/Off button:** activates/deactivates the function

10 - **Favorites button:** places the function in the favorites tab, very useful when using the function many times.

## NOTES

*If only the active functions are showing, it is necessary to check if the functions filter is activated. To do so, click on the button (8).*

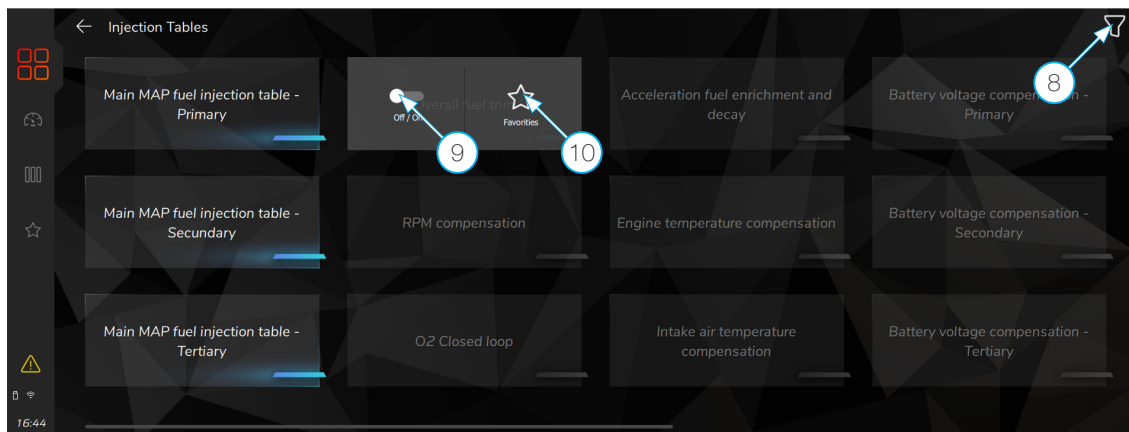

## Interface function

All functions have the same interface, and are divided into two tabs: “Settings” and “Settings”.

11 - **Function name**

12 - **Adjust tab:** this tab adjusts the function's operating values. This is where it is changed whenever it is necessary to change some operating parameter.

13 - **Config tab:** This tab contains the function settings. It is used to configure how the output will be activated and under what conditions.

14 - **Undo/redo/save/discard buttons**

15 - **Sliding tab:** This tab contains the graph, some engine operating parameters in real time and also the software help. For FT700PLUS this tab is displayed permanently.

16 - **Slider button:** It follows the same logic as the PowerFT line, where there was a check box to enable a specific condition within the function.

17 - **Page indication:** Indicates that there is more than one screen to configure. Click on the side of the bar to navigate within the function.

18 - **Slider bar:** this bar adjusts the parameter value. You can click on the +/- buttons to adjust the value by 1 by 1 or click on the center of the bar and pull the bar to the side and increase the value quickly. You can also click on the value and enter the desired number

19 - **Change indicator:** Whenever there is any change in the parameter, it will show a yellow circle, this circle represents that there has been a change and will only be deleted when the save or undo button is pressed.

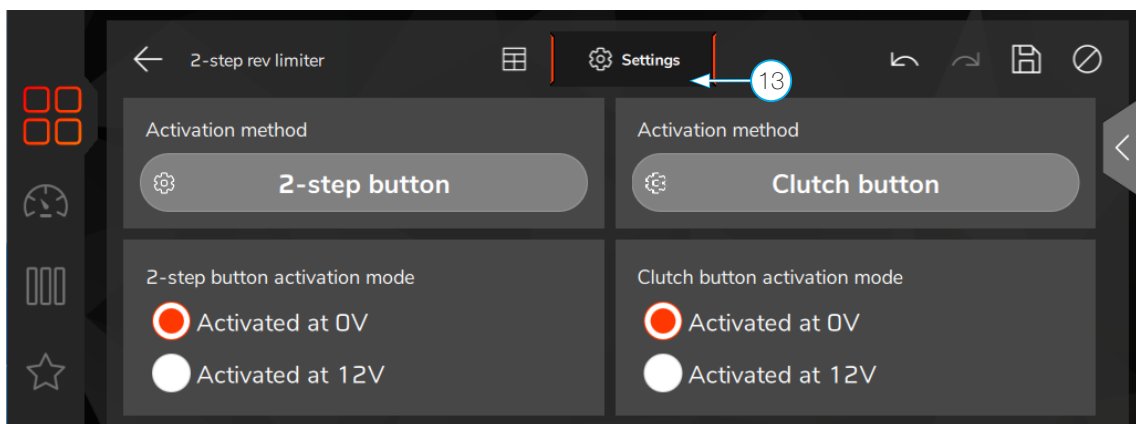
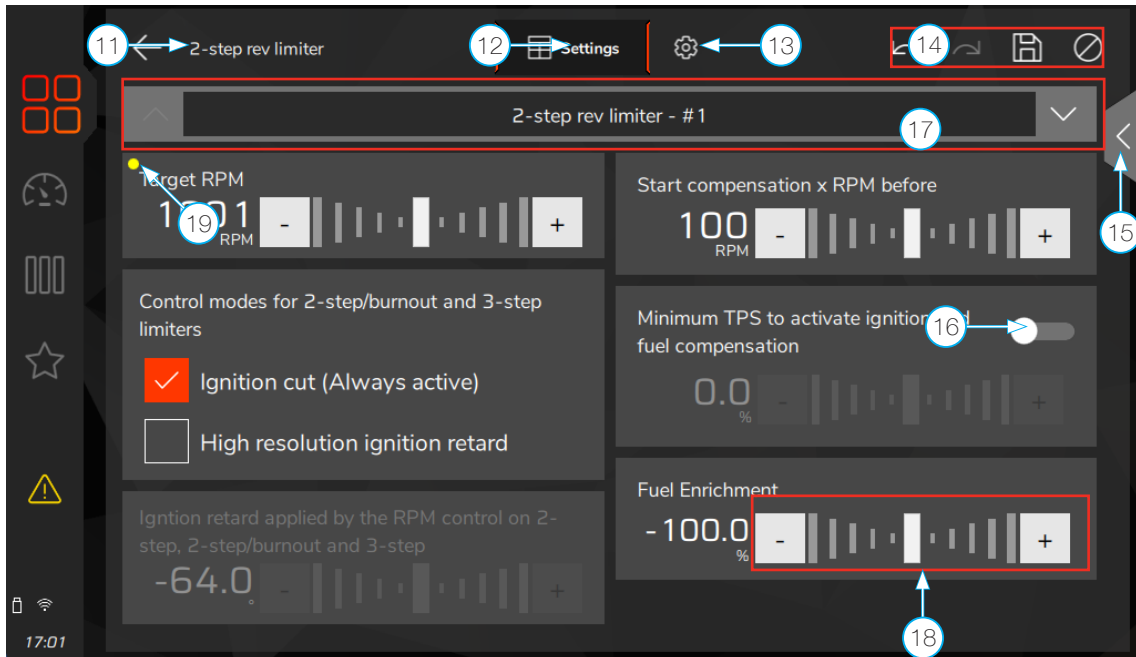

### Interface dashboard

To access the dash, click on the button (2) in the sidebar. To access the side menu, just click on the left side of the screen.

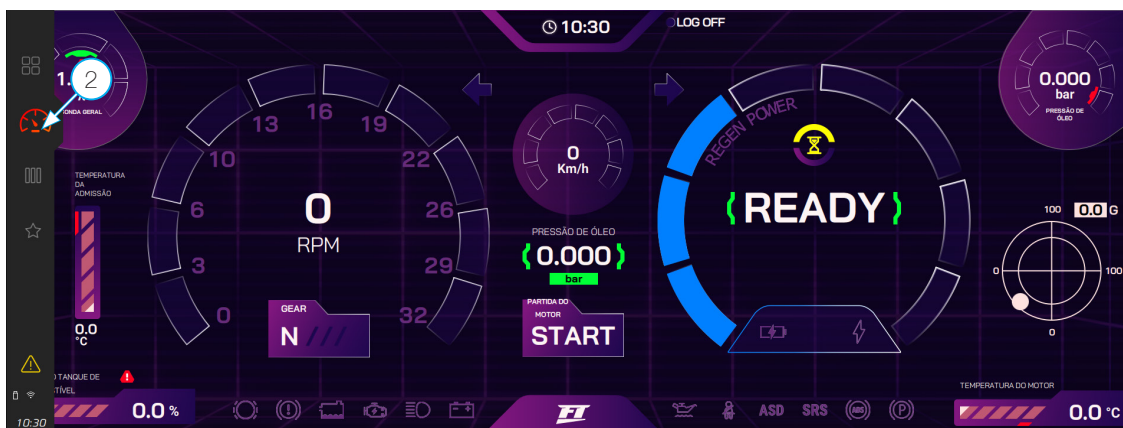

## Alert messages and connectivity buttons

To access this menu, click on the attention icon (5). This menu displays all alert messages present on the VCU, as well as the VCU connectivity buttons such as:

- Wifi network button
- Bluetooth Button
- Log start and end button
- Internet connection button and cloud map
- Dash real-time
- VCU suspend button
- VCU off button



## 6.2 FuelTech Vision software interface (desktop)

Desktop software has the same functionality as VCUs, but in a few different locations. When opening the FuelTech Vision software, the screen shown below will appear, where it is possible to see the recent maps and logs, also the files that are in the VCU and those that are available in the cloud (INTERNET).

There are several quick access buttons for reading and writing the map on the VCU, calibrations and log management.

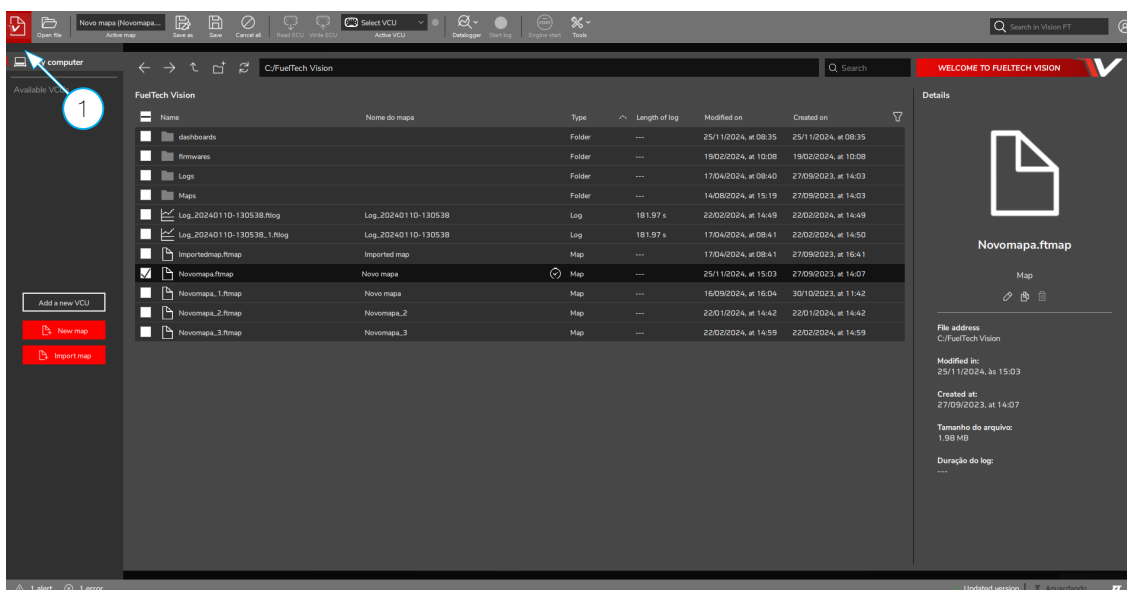

After clicking on the icon (1) the interface shown below will open.

- 2 - **Top bar:** Map identification, save and undo buttons and cloud login.
- 3 - **Sidebar:** Gives access to all VCU functions)
- 4 - **Status Bar:** Displays error and warning information, as well as important update information for the VCU.
- 5 - **Hide names button:** Hides the names of the functions, leaving only the icons.
- 6 - **Background tasks:** this menu displays all the tasks running in the background, usually when an error occurs in services, an alert is displayed in this area.

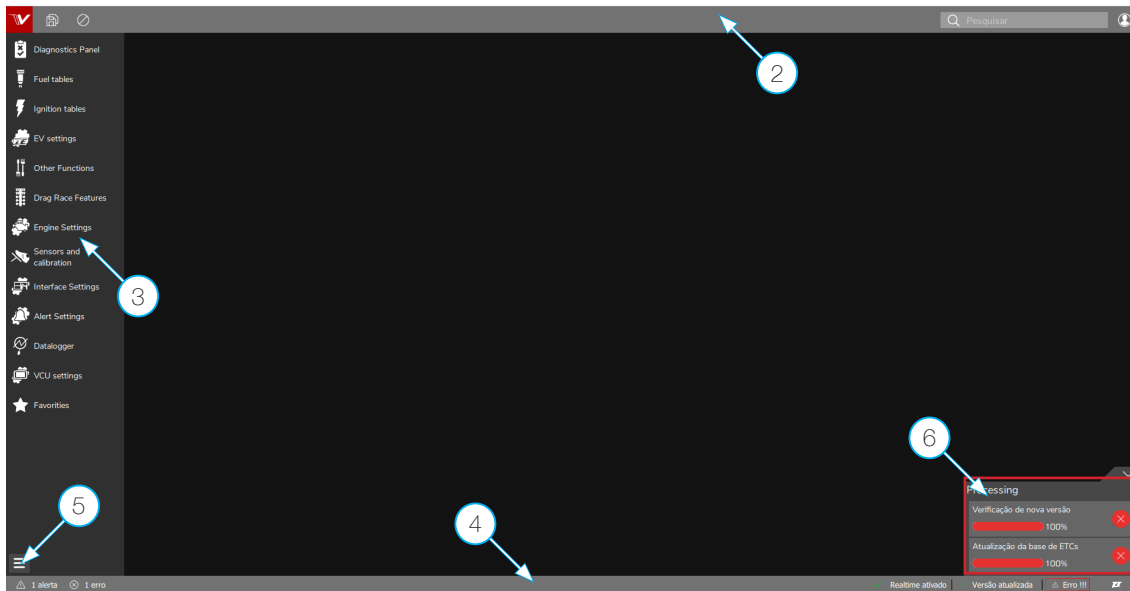

### General interface function

Through the sidebar (3) it is possible to access all the functions of the VCU, identified by the drawings of the functions, Fuel tables, Ignition tables, EV settings, Other functions, Drag race features, Engine settings, Sensors and calibrations, Interface, Alerts, Datalogger and VCU settings and Favorites.

Clicking on one of the icons will open a sub-menu with all the functions related to that group. As shown in the figure below, there are active and deactivated functions, to make a function active it is necessary to click on it with the right mouse button, a menu will open and the ON option will be available.

To make visible only the active functions there is a filter button (6).

A great function in the desktop software is the possibility of opening several functions at the same time, browsing and configuring with just one click, as shown in the figure below by item (7). The active function has its box filled in the color of the function's main group.

The area (8) marked in red is intended for function configuration and adjustments as well as the function's graphic representation.

For cases where there are tables, it is possible to edit them in several ways:

- Editing a single value
- Selecting multiple fields
- Clicking with the right mouse button will open the selection menu
- +/- Button on keyboard

And finally we have the area (9) where it is possible to configure a panel in real time. This panel is customizable for each role and will change depending on the role selected.



## Datalogger Interface

FT700 Logs can now be viewed and edited directly from the VCU screen.

1 - **Open log name**

2 - **Log control bar:** allows you to define different settings for the open log.

*Zoom in:* expands the view of a specific part of the log.

*Zoom out:* returns to the normal view of the entire log.

*Set to origin:* Places the view at the beginning of the log

*Set origin:* sets the beginning of the log to the point where the cursor is at that moment

*Overlay:* opens adding the map directly to the log all changes made in this mode will be shown with a dotted line in the log. When enabling this function, items (6) and (7) are added to the log screen.

*Group mode:* separates the channels listed in item (4) into specific groups.

*Save & Undo:* these buttons save or undo changes made to the log/map.

*Settings:* enables and disables channels, colors, groups, minimum and maximum filters for this log. To switch to the other logs, access the Datalogger function within other functions.

3 - **Channels bar:** In this bar there are three subdivisions, as you select the subdivision the channels of item (4) will change.

*123 values:* shows the log channels with the current values for the specified cursor position.

*Status events:* shows the errors that occurred while recording the log.

*Minimum and maximum:* shows the minimum and maximum values for each log channel.

4 - **Log channels:** Shows all log channels with their respective values, next to each channel there is a "checkbox" to show the channel in the graphic area.

5 - **Graphic area:** shows the log in graphic mode.

6 - **Available channels:** for editing within the log. They will only be available after the "Overlay" button is activated.

7 - **Tables:** for editing the map inside the log. They work together with item (6).

8 - **Table editing bar:** In this bar there are several buttons to facilitate the editing of the table.



### 6.3 Mobile interface

The mobile interface was developed for smartphones and is practically the same as the interface embedded in the VCU. The smartphone can be used with an additional screen for the VCU so it is possible through a wi-fi or Bluetooth connection to monitor the car's operation in real time without necessarily being inside it or with a cable connected.

There is a bottom bar of the screen where the navigation buttons between various functions of the VCU are located. This bar is the same as on other platforms.

- 1 - **Function menu button:** this button opens the function groups.
- 2 - **Instrument panel button:** goes to the configured instrument panel.
- 3 - **Favorites button:** shows favorite functions
- 4 - **Recent button:** memorizes the last accessed functions.
- 5 - **Connection status:** in this field it is possible to view the active connections on the VCU (Ethernet, USB, Wi Fi, Bluetooth)

#### Interface function

All functions have the same interface, and are divided into two tabs: "Settings" and "Settings".

- 6 - **Function name**
- 7 - **Adjustments tab:** on this tab adjust the contour settings of the function. In this tab that is worked whenever necessary to change some operating parameter.
- 8 - **Settings tab:** This tab contains the function settings. It is used to configure how the output will be triggered and under what conditions.



9 - **Undo/redo/save/discard and chart buttons**

10 - **Sliding button:** It follows the same logic as the PowerFT Line, where there was a check box to enable a special boundary condition within the function.

11 - **Slider bar:** this bar adjusts the parameter value. You can click on the +/- buttons to adjust the value by 1 by 1 or click on the center of the bar and pull the bar to the side and increase the value quickly. You can also click on the value and enter the desired number

12 - **Change indicator:** Whenever there is any change in the parameter, it will show a yellow circle, this circle represents that there has been a change and will only be deleted when the save or undo button is pressed.

13 - **Selection button:** This button allows changing the type of selection of table values. To select more than one value at a time, button (13) must be active.

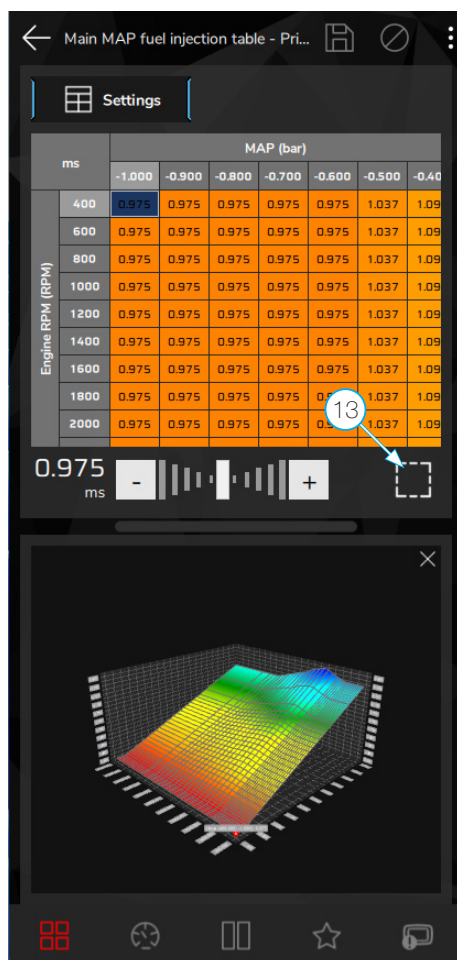
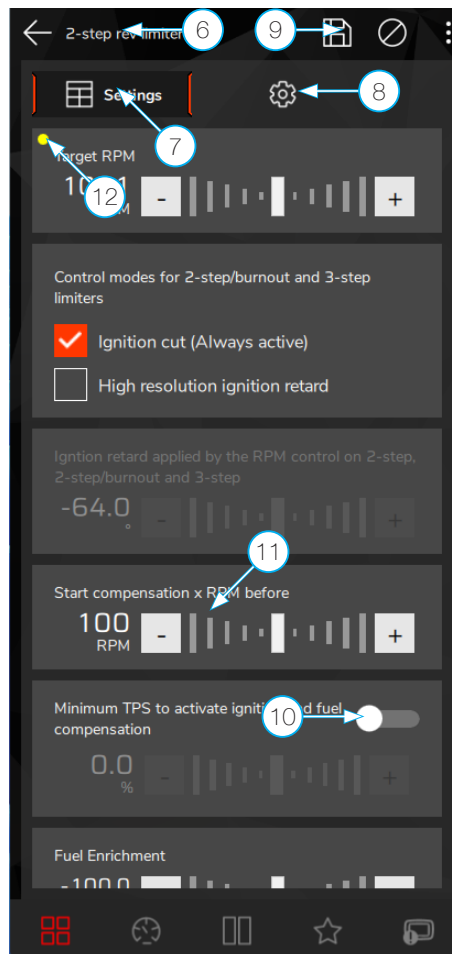

**NOTES**

*In the smartphone interface it is necessary to scroll the screen upwards to show all available settings for each function.*

## 6.4 Gestures

The FT700 and FT700Plus work through gestures on the interface, just like a smartphone.

- 1 - **Tap**: select a field in a table, open a function, general navigation.
- 2 - **Touch and drag**: select a group of data within a table, modify the value in a field with sliders. This movement, when made in the left corner of the screen, opens the side menu to access the VCU functions.
- 3 - **Pinch**: zooms in on tables and graphs.
- 4 - **Double tap**: opens the field editing calculator within a table

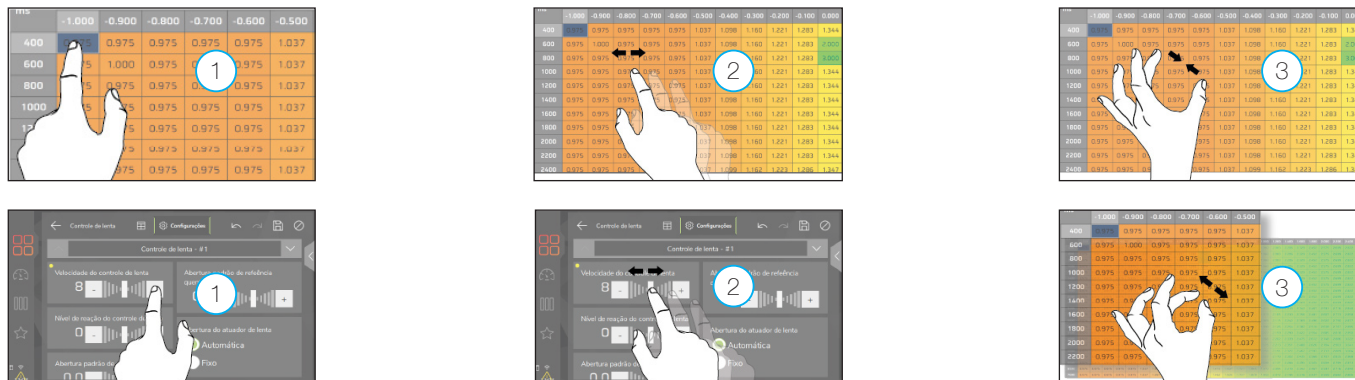

## 6.5 Hot Keys

There are several shortcut keys to speed up the use of the software.

General	
ctrl+tab or ctrl+- shift+tab	Switch between logs and open functions
ctrl+w	Closes current open logs or function
f1	Expands the right side menu within the functions (Area the help, graphics, etc. are located)
In the Log	
ctrl+(+)	Zoom in
ctrl+(-)	Zoom out
Left	Move 10ms to the left
Right	Move 10ms to the right
shift+left	Move 1ms to the left
shift+right	Move 1ms to the right
ctrl+left	Move 100ms to the left
ctrl+right	Move 100ms to the right
alt+left	Shifts the timeline 1/4 to the left
alt+right	Shifts the timeline 1/4 to the right

In the Tables	
+	Increases value
-	Decreases value
ctrl+(+)	Increases value quickly
ctrl+(-)	Decreases value quickly
Shift+(+)	Increases value slowly
Shift+(-)	Decreases value slowly
a	Opens add popup
m	Open multiply popup
Space	Open edit popup
ctrl+c	Copy cells
ctrl+v	Paste cells
i	Interpolate
h	Interpolate horizontally
v	Interpolate vertically
s	Smooth
h	Apply closed loop correction (in fuel tables)

## 6.6 Connectivity

VCUs from the VisionFT line allow different types of connections such as: Wi-fi, Bluetooth and cable. To connect to the VCU, it is necessary to carry out the procedures described below depending on the chosen platform.

### Connection to VisionFT Software (Wi-fi)

For this connection it is necessary to first place the VCU on the same network as the desktop.

a - On the VCU menu screen, access the “VCU Settings” function (1).

b - Click on the “Wi-fi” function (2) to open the settings.

c - Within the Wi-fi function settings there are two “Wi-fi operation modes”:

- **Device mode:** lists all available Wi-fi networks in the location. When choosing this option, all devices must be on the same network to work.

- **AP mode:** in this mode an exclusive network is created for connection between the VCU and the connecting devices, in this case it is necessary to configure the network name and password.

d - After connecting to the chosen Wi-fi network, you need to connect to the device. To do this, open the side menu on the VCU by clicking on the icons (3) and after clicking and holding the Wi-fi button (4), a screen will open with the password for pairing the two devices. Enter this password on the device you want to connect to the VCU and the connection will be executed automatically every time as soon as the software is opened.

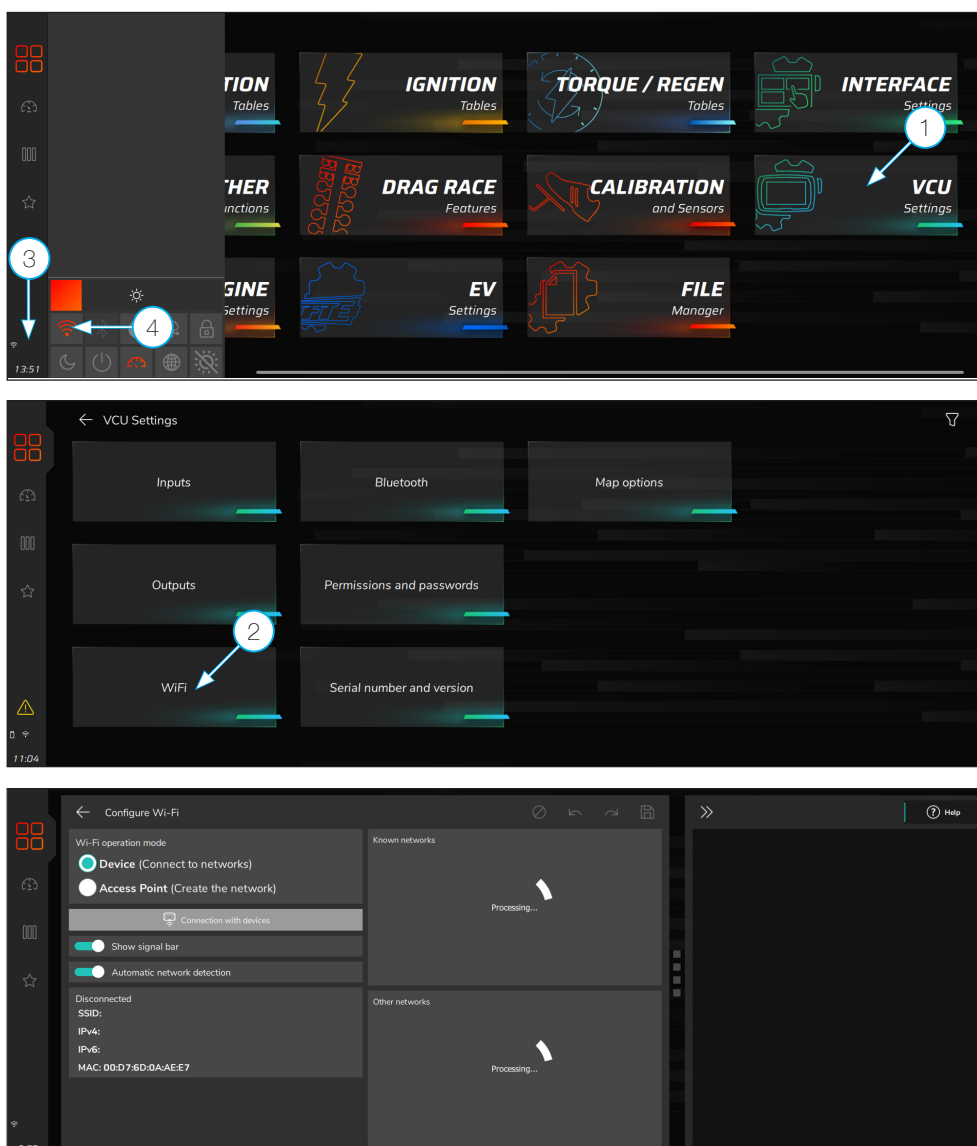

## Connection with VisionFT Software (Bluetooth)

This connection follows the same procedures as the Wi-fi connection.

### NOTES

*This type of connection may present a delay in some cases as it has a lower transfer rate. To have real-time data, we recommend using a Wi-fi network or a USB cable.*

## Connection to VisionFT Software (Desktop)

Connection via desktop software is made via the main screen. Click on the “Add new VCU” button (1) to list the VCUs available on the network, then enter the pairing password to authorize the connection.

Already paired VCUs will be automatically connected and will appear in the left sidebar. To access them, click on the name and the maps and logs available at VCU will open.

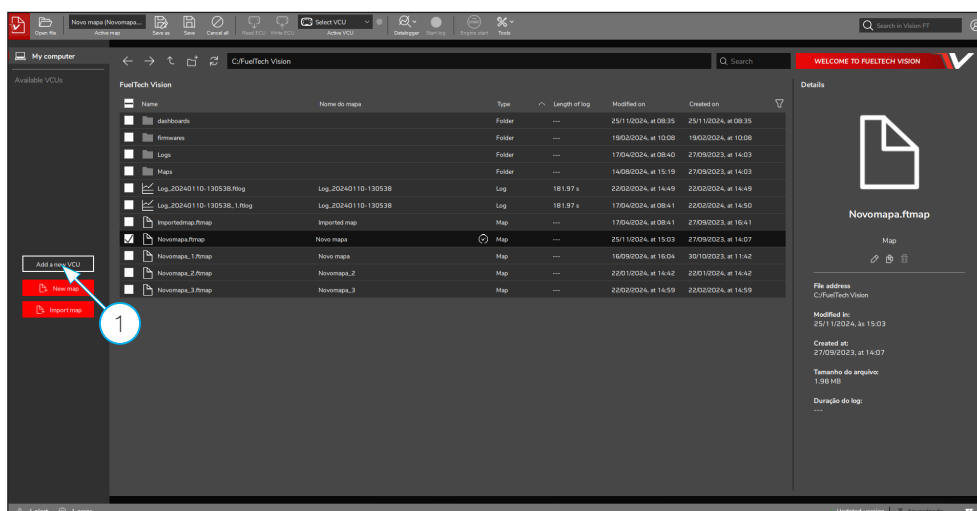

## 6.7 FT700 disassembly

This procedure is necessary when installing the VCU in a instrument panel.

To remove the front bezel, follow the procedure described below.

a - There are two locking slots on the bottom of the FT700. Insert a screwdriver or other suitable lever into these slots and force the lever down, pushing the front bezel forward until you hear a click in both slots, as shown in figure (1) on the next page.

b - After the front bezel is released from the bottom, it is necessary to pull out the top part. The part offers resistance, as shown in figure (2).

c - There are two holes on each side to install the FT700 to the vehicle's instrument panel, as shown in figures (3 and 4).



### 6.8 FT700Plus disassembly

This procedure is necessary when installing the VCU in a instrument panel.

To remove the front bezel, follow the procedure described below.

- a - Remove all screws (5) from the rear bezel (6) and remove it.
- b - Turn the FT700Plus over and remove the front bezel (7).
- c - Use the holes (8) to secure the FT700Plus to the vehicle's instrument panel.

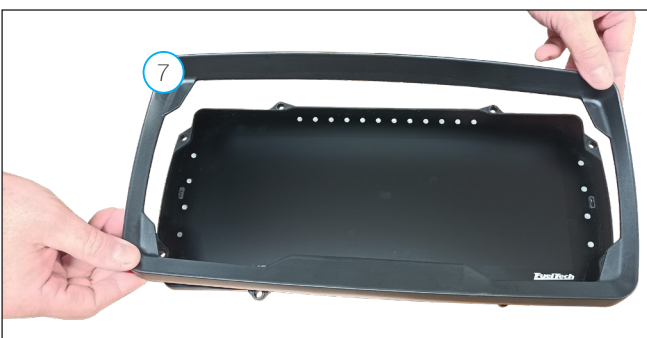

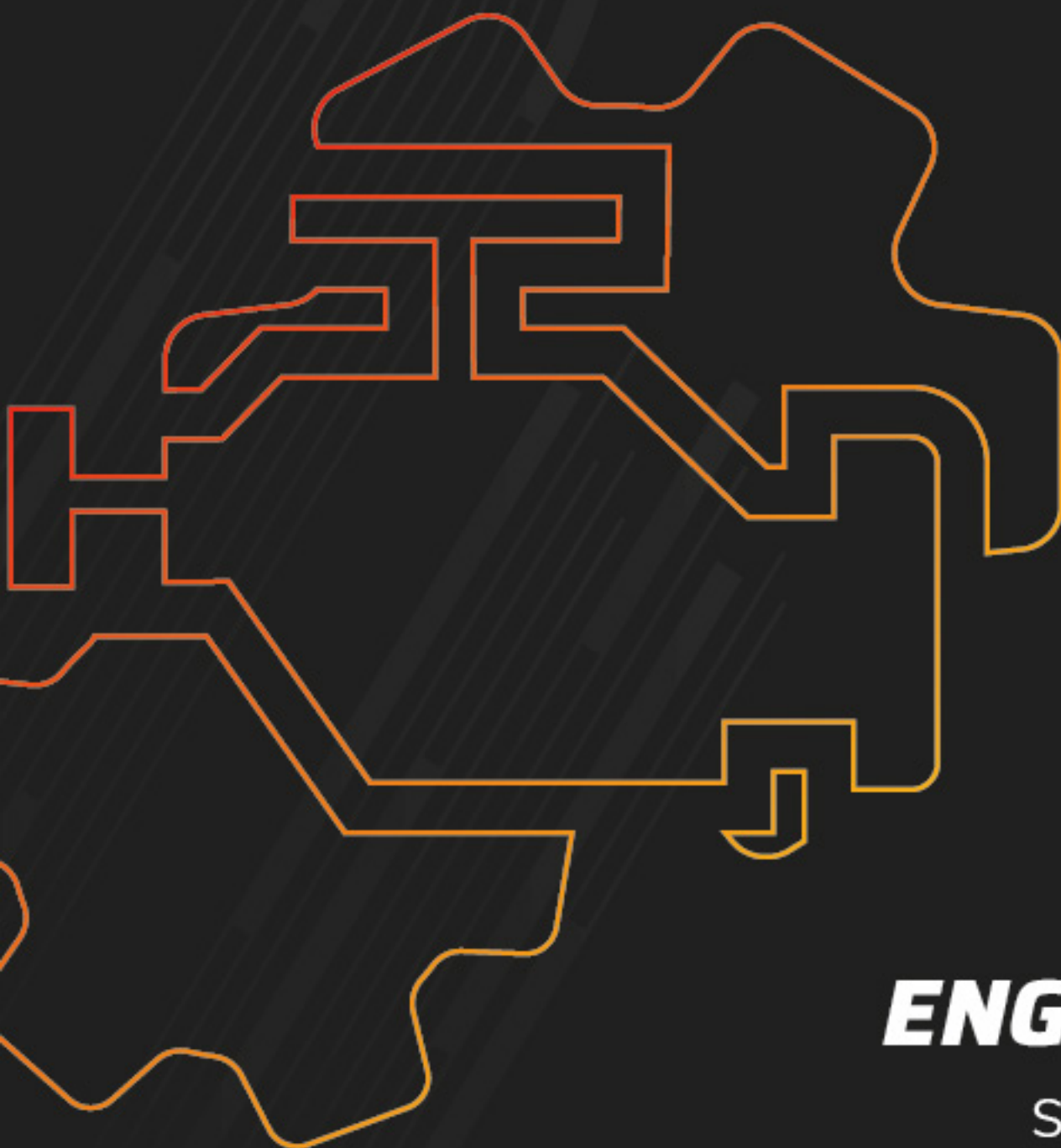

# ***ENGINE***

Settings



## 7. Engine settings

FuelTech VCUs leave the factory without maps or adjustments, so you need to create the injection maps, ignition and the inputs and outputs settings before running the engine.

The FuelTech default is an automatic calculation of the basic injection and ignition maps for your engine based on the information provided in the “*Engine Settings*”. Performing this automatic adjustment every injection and ignition maps, including temperature compensation, etc. Will be filled based on your engine characteristics. The information provided must be correct and consistent, maximum RPM and boost values should be according to the engine capacity and the injectors should be properly sized to the estimated engine power.

The use of an instrument, such as oxygen sensor (wideband recommended) and/or an analyzer of exhaust gases, to make the analysis of the air/fuel mixture is extremely important.

Caution, especially during start-up, is needed, since it is an initial tune that will start most engines, there are no guarantees for any situation. Be extremely cautious when tuning your engine. Engine should not be operated at maximum load until the air fuel ratio has been confirmed.

Start tuning with a rich map and a conservative timing, because starting with a lean map and advanced timing can severely damage the engine. Start the basic adjustment with the rich map, that is, start the engine tuning always injecting more fuel than you really need and with the most conservative ignition timing, because starting with the lean map and with advanced timing can seriously damage the engine.

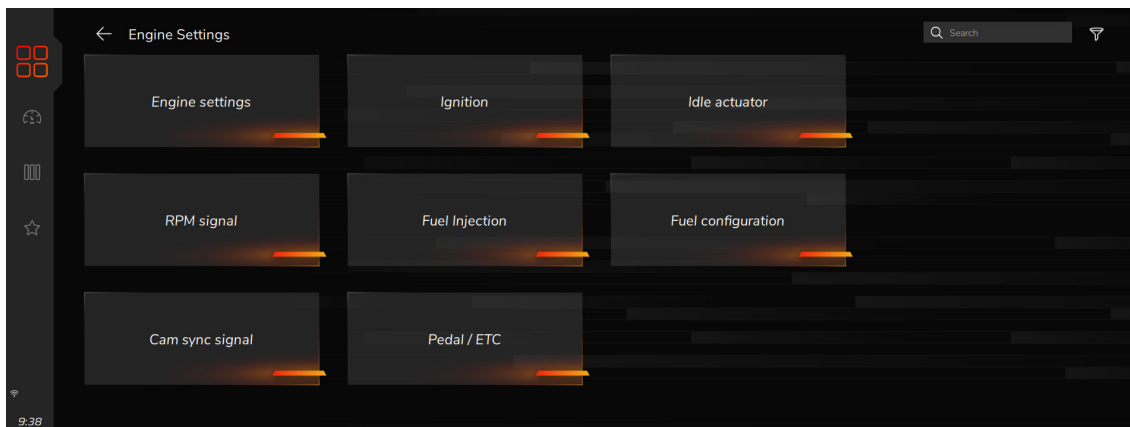

### 7.1 Engine setup

This function configures the type of motor and operating limits.

#### Engine type and number of cylinders:

Select the type of engine used, piston (Otto cycle) or rotary (Wankel) and select the number of cylinders or rotors.

#### Firing Order

Select the firing order according to your engine.

##### 4 cylinder engines

- 1-3-4-2: majority of engines, VW AP, VW Golf, Chevrolet, Ford, Fiat, Honda, etc.;
- 1-3-2-4: Subaru;
- 1-4-3-2: air-cooled VW;
- 1-2-4-3: Motorcycles (majority)

##### 5 cylinder engines

- 1-2-4-5-3: Audi 5 cylinders, Fiat Marea 20V and VW Jetta 2.5;

##### 6 cylinder engines

- 1-5-3-6-2-4: GM in line (Opala and Omega), VW VR6 and BMW;
- 1-6-5-4-3-2: GM V6 (S10/Blazer 4.3);
- 1-4-2-5-3-6: Ford Ranger V6;

##### 8 cylinder engines

- 1-8-4-3-6-5-7-2: Chevrolet V8 (majority);
- 1-8-7-2-6-2-4-3: Chevrolet LS
- 1-5-4-2-6-3-7-8: Ford 272, 292, 302, 355, 390, 429, 460;
- 1-3-7-2-6-5-4-8: Ford 351, 400 and Porsche 928;
- 1-5-4-8-6-3-7-2: Mercedes-Benz;

### 10 cylinder engines

- 1-10-9-4-3-6-5-8-7-2: Dodge V10;
- 1-6-5-10-2-7-3-8-4-9: BMW S85, Ford V10, Audi, Lamborghini V10;

### 12 cylinder engines

- 1-12-5-8-3-10-6-7-2-11-4-9: Jaguar V12, Audi, VW, Bentley Spyker W12;
- 1-7-5-11-3-9-6-12-2-8-4-10: 2001 Ferrari 456M GT V12;
- 1-7-4-10-2-8-6-12-3-9-5-11: 1997 Lamborghini Diablo VT;

### Custom

In case the firing order of your engine is not listed on the VCU, there's a mode that allows full customization of the firing order.

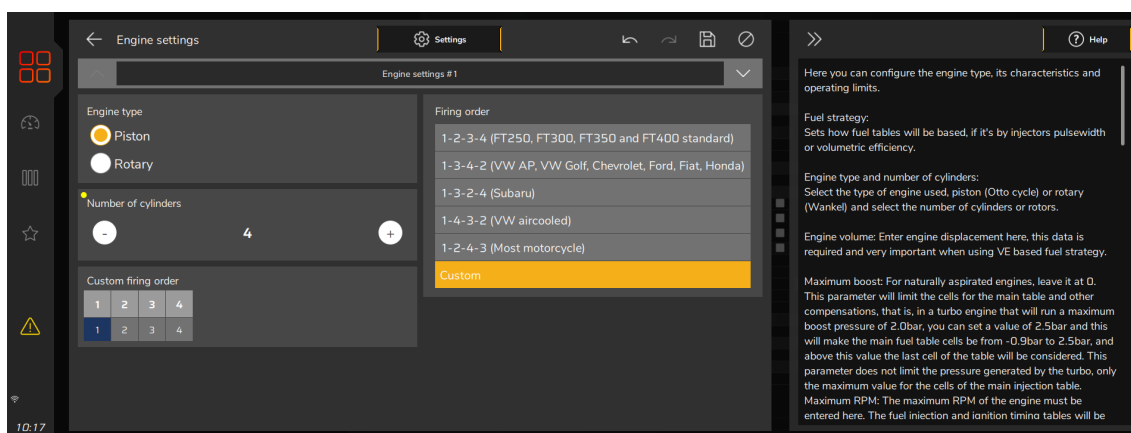

### Enable outputs

Basically prevents the outputs from turning on (injection, ignition and auxiliary outputs).

### Main fuel table

**MAP:** this mode is indicated for turbo or naturally aspirated engines. That's the mode that better represents engine load, because engine vacuum varies under different loads, even with the throttle on the same position.

**TPS:** this option is mostly used on naturally aspirated engines with aggressive camshafts, when this causes the vacuum on idle and under low load conditions to be unstable. When this option is selected, MAP compensation is available for fuel and timing maps.

**TPS idle fuel injection table:** This is the mode the fuel injection on idle speed will be controlled. When enabled, a table that relates injection time versus engine RPM is activated whenever TPS is equal to 0%. Enable this feature on engines with high profile camshafts and unstable vacuum on idle.

For street cars with stable vacuum on idle, it is recommended to keep this feature disabled. In this case, injection time for idle will be set up directly on the vacuum ranges on the main fuel MAP.

**Acceleration fuel enrichment:** use this parameter set up as TPS whenever possible, as this sensor reacts faster than the MAP sensor to indicate a quick change of position in the throttle.

### Fuel strategy

Defines the VCU's operating mode for controlling the fuel in the engine.

**Injector Pulse width:** mode that uses time (milliseconds) to control fuel injection. This mode is the same as that used in the PowerFT line modules.

**VE based:** this mode allows you to create injection maps based on the engine's volumetric efficiency.

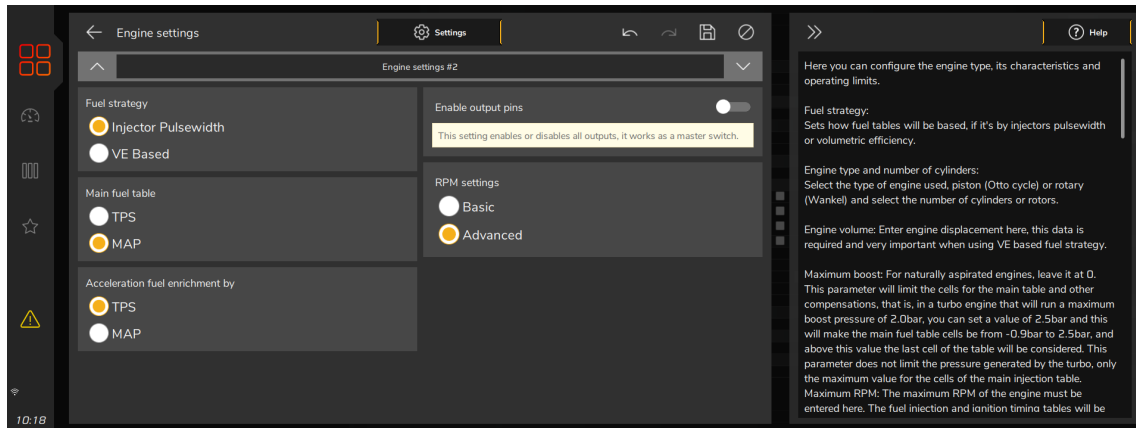

## Engine limits

Setup the maximum RPM and maximum boost.

**Maximum RPM:** setup the engine maximum RPM. All fuel and timing maps will be created with its last point on this RPM. This parameter is also used to calculate fuel injector's percentage of use.

**Maximum boost:** maximum boost for fuel and ignition maps. For naturally aspirated engines, set this option as 0.0psi. For turbocharged engines, use 10psi above the maximum boost the engine will effectively be using. In case of an overboost, the VCU will apply the last injection timing set on the map. This option doesn't control boost pressure, is just a limit for fuel and ignition maps.

**RPM for engine start:** set up a RPM limit above which the start-up routines are disabled. Below this RPM, all the injection, ignition and actuator positions set up for engine start are used.

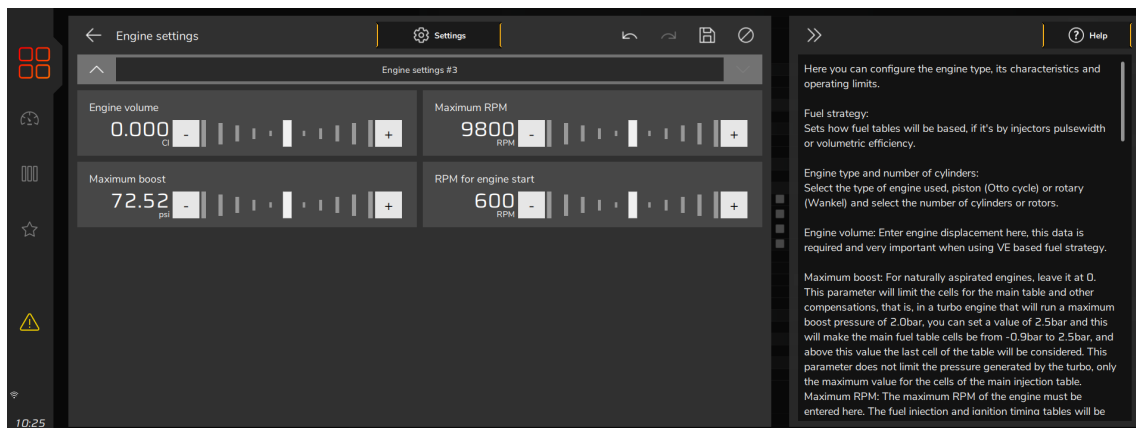

## 7.2 RPM signal

RPM signal is the most important information to run the engine properly. This menu is where the RPM input will be set up.

**Engines with crank trigger:** select the crank trigger pattern. Select the crank trigger or distributor pattern. In case of a crank trigger without missing tooth and multi-coils, a cam sync sensor is required. When using a single coil, the cam sync sensor is not mandatory. A several options of standard patterns are available for using with multi coils or distributor based systems.

### Sensor type

Select the RPM sensor used on the vehicle, VR or Hall Effect.

**VR internal ref:** Only use this option when told by our tech support. This is used for compatibility with older units only.

**VR Differential:** Select this for VR sensors; it's less susceptible to electromagnetic interference. When the crank trigger signal is split with the OEM VCU this option is mandatory.

**Hall:** Select when using Hall effect RPM sensor or when experiencing problems with electromagnetic interference.

### Sensor Edge

This option changes the way the VCU reads the RPM signal. As there's no simple way of telling which one is the correct option (without an oscilloscope), select the option Standard (Falling Edge). If the VCU sees no RPM signal during initial startup, change this parameter to Inverted (Rising Edge)

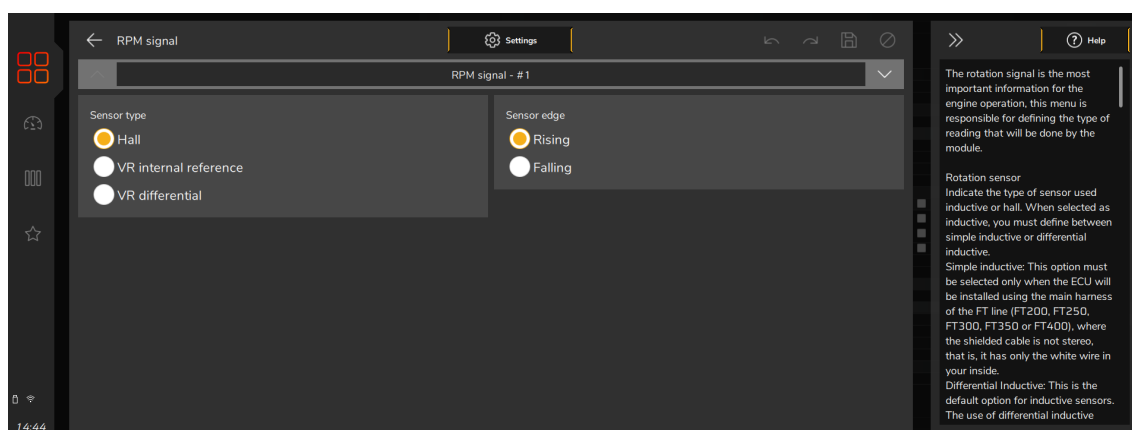

## Crank trigger wheel

Select the crank trigger model used in the motor.

**Engines with distributor:** hall effect and magnetic distributors are compatible with this VCU. The signal input configuration must be done according to the number of pick-ups/windows on the distributor.

**Engines with crank trigger/distributor (1 ignition coil):** in this case the VCU reads a crank trigger on the crank (or at the cam), but the ignition distribution occurs on a distributor, through a single coil.

In this case, the RPM Signal configuration remains the same as engines with crank trigger and multi coils, the difference here is the menu "Ignition Mode" must be set as distributor.

That enables only the ignition output #1. The other outputs stay disabled and unused.

## Crank index position

Set here the crank trigger alignment related to the TDC. This alignment can be checked by turning the engine to the cylinder #1 TDC and counting, counterclockwise, the distance in teeth, from the crank trigger gap to the RPM sensor.

**Custom crank:** When selecting this option, it is necessary to configure the parameters.

**Sensor type:** Four configurations available: No missing tooth, with missing tooth, with additional tooth and multiple missing tooth.

**Crank trigger number of teeth:** Defines how many teeth the crank trigger.

**Number of missing teeth:** If the crank has missing teeth, it is necessary to configure how many teeth are missing.

**Additional tooth angle:** If the crank has additional teeth, it is necessary to set the angle.

**Gap Duration Time:** Adjusts what the gap duration is for the additional tooth.

**Smart cranking rpm sync:** Option to allow faster RPM detection during cranking, specially for high compression ratio and light weight rotating setup, such as motorcycle engines.

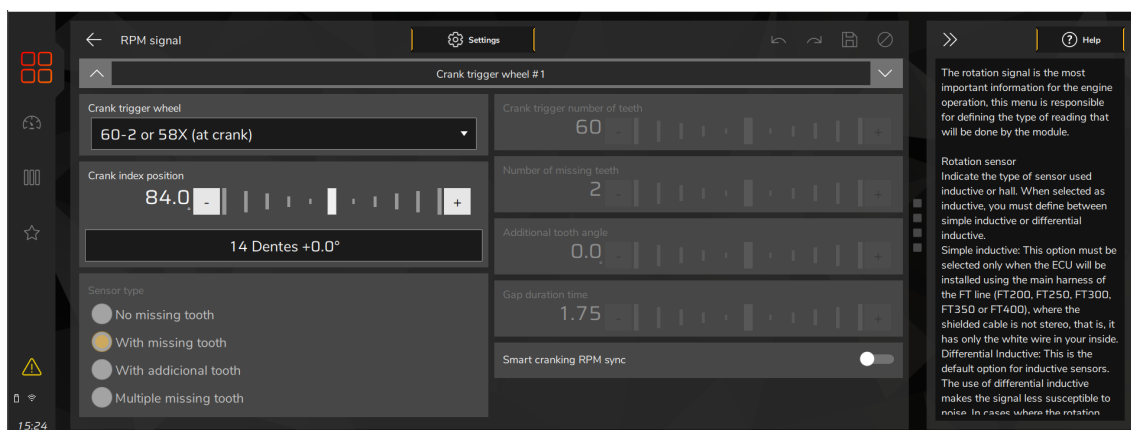

## WARNING

Ignition calibration values on this table are just a start point. ALWAYS perform the ignition calibration according to chapter 16. When the ignition is not correctly calibrated, the timing shown on the VCU screen is different from the one that is being applied to the engine. This may cause serious damage to the engine.

For engines with distributor and Crank trigger, check our Technical Support for information about the alignment in use. Below is a table with known alignment values and configurations for most of the cases:

Crank trigger - pattern	Engine / brand	Recommended Index position	Cam sync sensor
60-2	BMW, Fiat, Ford (inj. Marelli), Renault, VW, GM	324° (BMW) 123° (GM) 90° (others)	Not mandatory
48-2			Not mandatory
36-1	Ford (injection FIC)	90°	Not mandatory
36-2-2-2	Subaru	55°	Not mandatory
36-2	Toyota	102°	Not mandatory
30-1			Not mandatory
30-2			Not mandatory
24-1	Hayabusa	110°	Not mandatory
24-2	Suzuki Srad 1000		Not mandatory
24 (crank) or 48 (Cam)		60°	Falling edge
12-3	Bike Honda CB300R		Not mandatory
12+1	Honda Civic Si	210° or 330°	Not mandatory
12-1	Bikes Honda/Suzuki/Yamaha		Not mandatory
12-2			Not mandatory
12 (crank) or 24 (Cam)	Bikes/AEM EPM/ distrib Honda 92/95-96/00		Falling edge
8 (crank) or 16 (Cam)			Falling edge
4+1 (crank)			Not mandatory
4 (crank) or 8 (Cam)	8 cylinders	70°	Falling edge
3 (crank) or 6 (Cam)	6 cylinders	60°	Falling edge
2 (crank) or 4 (Cam)	4 cylinders	90°	Falling edge

The following image shows how the configuration looks when a custom crank trigger is selected.

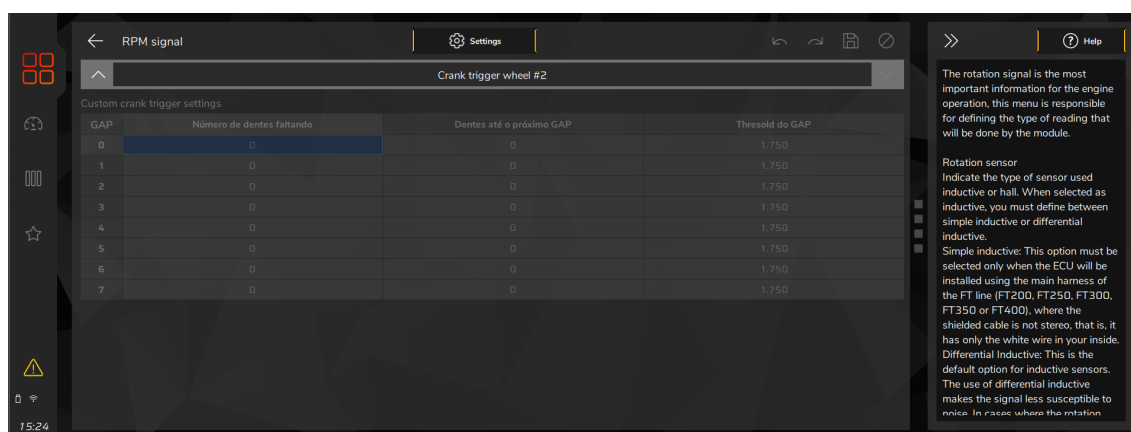

### Activate internal load for sensor

An advanced setting that should only be used when there is noise in the RPM signal.

### Sensor conditioning mode

Changes the rotation signal capture parameters.

## NOTES

*Internal load and conditioning mode settings should only be changed with guidance from FuelTech technical support.*

### 7.3 Cam sync sensor

This option indicates if a cam sync sensor will be used and if it uses a hall effect or magnetic variable reluctance (VR) sensor. This sensor is mandatory when controlling fuel or timing in sequential mode. Without cam sync sensor the injection mode will be only semi-sequential or multipoint. Ignition will be always wasted spark.

Random cam sync sensor option is a test mode that automatically assumes a position for the cam sync signal. Use this only for testing purposes, as this may cause misfires in some applications. Use this option only for tests, because with individual coils and sequential ignition the firing order can be lagged (inverted) in 360°, so the engine won't start.

**Cam sync sensor for synchronization only:** This option will use the cam sync sensor for engine synchronization only, after 10 revolutions the signal is disconsidered for the remainder of the run.

**Cam sync position:** This is the physical position in angles where the sensor is installed in relation to the first cylinder combustion stroke (BTDC) and is mandatory when using any of the sequential features.

In case the angle is not know, it is possible to find it using the "Diagnostic" option for the sensor type, and reading the detected value either by recording a datalog or consulting the diagnostic panel in the VCU display, after getting the value, insert it here and change the sensor type back to the correct option.

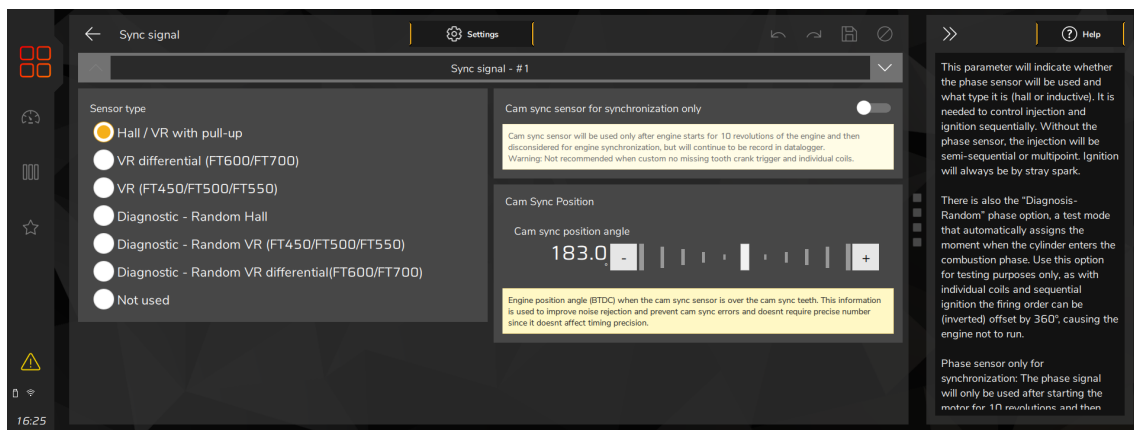

**CAM sync reading mode:** Select if there's a single tooth or multi-teeth used for cam sync, and in case there are multiple teeth, a tolerance between them must be set next, this value is in percentage and it's based on a table that must be set through Vision FuelTech software.

**Single tooth:** This option should be selected when there's only one tooth for reference or when creating an exclusion window on multiple teeth to use a single reference.

**Sensor edge:** This option will select which of the signal edges is considered for reference.

**Window filter detection angle:** This option can be used to create a filter that will exclude all other signal edges found outside of this angle.

**Multiple teeth:** This option should be selected when there are multiple teeth for reference.

**Teeth tolerance:** The tolerance between the signal edges for the reference tooth.

**Teeth table:** This table is used to insert the initial and final angle of each tooth. It can be automatically filled out using the Wheel decoder. Use the Wheel decoder to automatically detect all teeth in the cam sync wheel. After running it, a list of all teeth will show up with their respective angles, one of them has to be selected as the reference.

#### NOTES

*Cam sync wheels with an even number of teeth that are equally spaced and completely symmetric, cannot be used.*

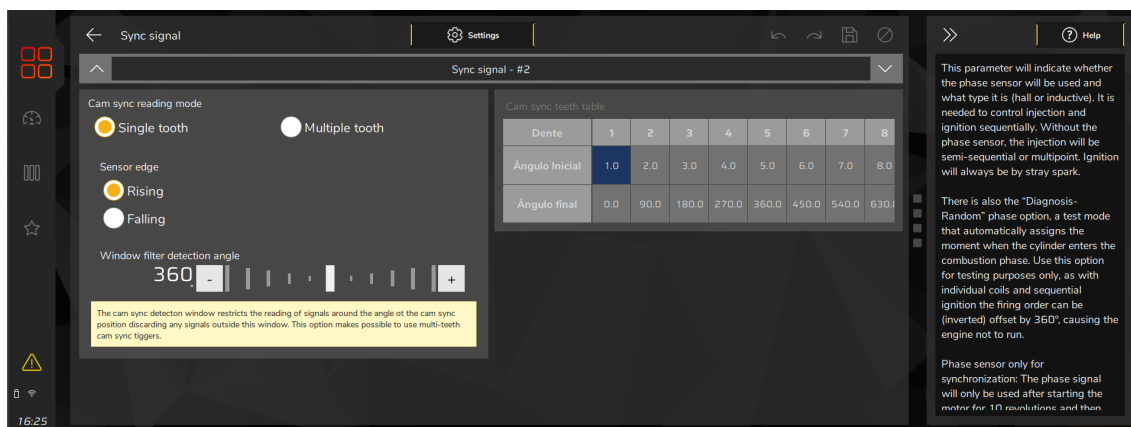

The advanced CAM sensor configuration mode should only be used when recommended by FuelTech technical support, as there is a risk of the engine not working if the configurations are wrong

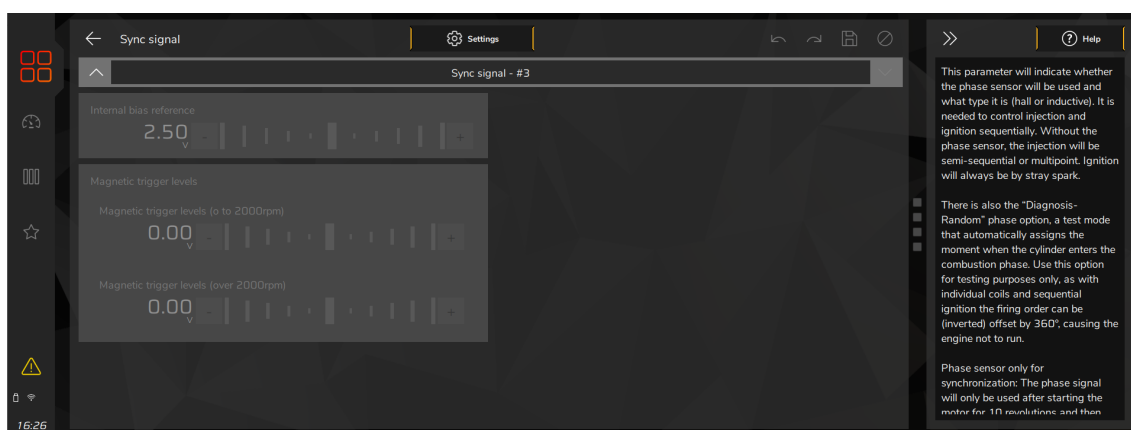

## 7.4 Ignition

This menu sets everything related to the ignition control mode and there is a “Default” mode (configurable through the VCU or PC) and a “Custom” mode (configurable only through the PC). When the ignition is set as “Disabled”, timing maps are unavailable and only the fuel control is enabled. Gray outputs are free to be set up as injectors or auxiliary outputs.

**Ignition timing:** select if the ignition will be controlled in sequential (cam sync sensor needed) or wasted spark modes or if a distributor will be used for that control.

The option “distributor” means that the spark distribution will actually be done by a distributor, with a single coil, regardless of the number of cylinders. Only the ignition output #1 (gray #1) will be used to control the ignition coil, the others are disabled.

Check “Double coil” when using wasted spark coils (two or more spark plug wires per coil). Check “Single coil” when using one coil per cylinder.

**Ignition output:** Select type of ignition

**Falling edge - (Smart Coil/SparkPRO):** when using smart coils (integrated igniter) or FuelTech SparkPRO modules. This mode has dwell control enabled.

**Rising edge - (MSD):** select this option when using MSD, Crane, Mallory or other capacitive discharge ignitions (CDI).

**Rising edge - (Honda Distributor):** this option must only be selected when using Honda distributor with stock igniter (the one that’s integrated to the distributor). This mode has dwell control enabled.

**FTSPARK Multiple wires:** this is the conventional way of connecting FT to any ignition module, using an ignition output to trigger each coil (double or single). In this case one or more ignition outputs will be connected to the FTSPARK.

**FTSPARK Serial output (1 wire):** Select this option to enable only one ignition output to send all the ignition trigger

signals to the FTSPARK via the FT Ignition BUS. In this way the other outputs that would be used for ignition can be reallocated to other functions.

**Ignition delay:** it is related to the time between when the igniter receives the ignition signal and fires the coil. The time is showed in microseconds.

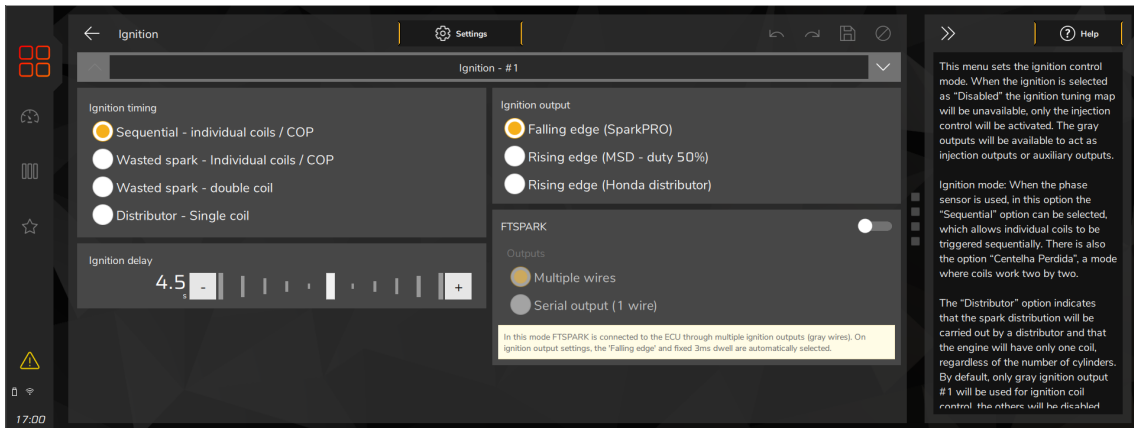

**Ignition cut:** The maximum level is the percentage of ignition event that will be cut to keep the engine under the rev limiter. The RPM progression range acts as a smoothing for ignition cut.

**Example:** rev limiter at 8000rpm, RPM progression range at 200rpm. From 8000rpm the ignition cut level will gradually increase until it reaches 90% cut at 8200rpm.

Percentages less than 90% may not keep the engine under the rev limiter. Bigger RPM progression range tend to stabilize more smoothly the rev limiter, but allows the RPM to pass the RPM set as rev limiter.

These numbers are valid to all kinds of ignition cut, with the exception of time based compensations (time based RPM and driveshaft RPM/wheel speed) and 2-step. These features have their own parameters.

For inductive ignition systems it is recommended to use 90% maximum level and 200 RPM progression range. For capacitive system, like MSD, it is recommended to use 100% maximum level and 10 RPM progression range.

 **WARNING**

*When the VCU is requested to apply more than one type of ignition cut from different functions simultaneously, the cut with the highest % configured will have priority, so the function with the lowest % of cut might not operate as expected.*

**Ignition dwell operation mode:** select the coil Dwell operation mode whether it will be by MAP and battery voltage or RPM and battery voltage.

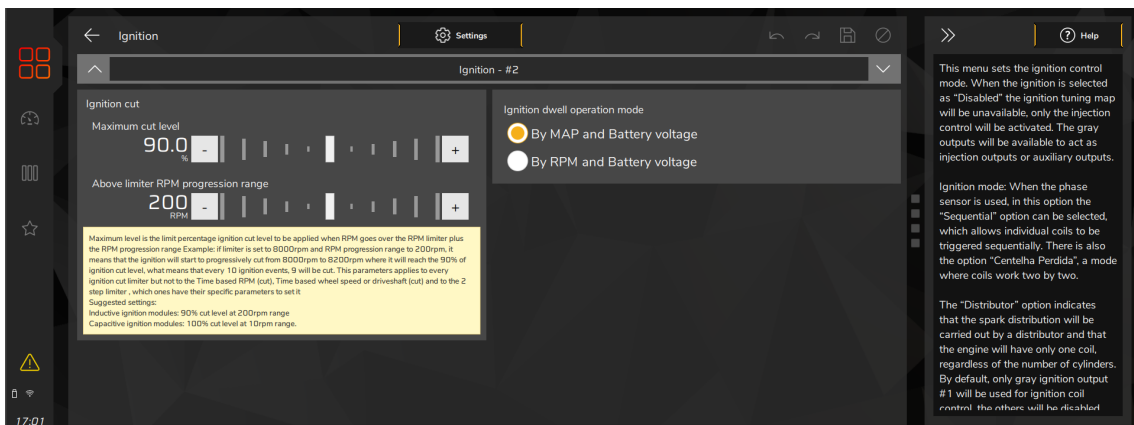

**Pin assignment mode:** Sets whether inputs and outputs will be automatically set when the map is generated.  
**Ignition angles assignment mode:** Allows you to set specific angles for each ignition.  
**Ignition current:** Sets a current for the ignition module.

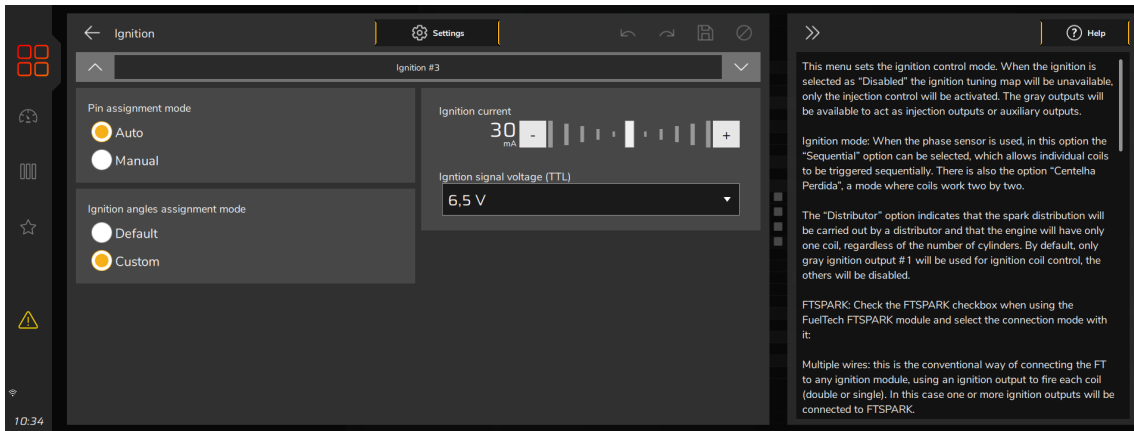

**Ignition angle table:** After generating FuelTech Default map, the VCU will automatically configure the Ignition angle table (Angle x cylinder), in this case the angle assignment mode will be defined as “Default”, without the possibility of alteration.

To change the angles manually, according to the desired parameters, it is necessary to change the assignment mode to “Custom”.

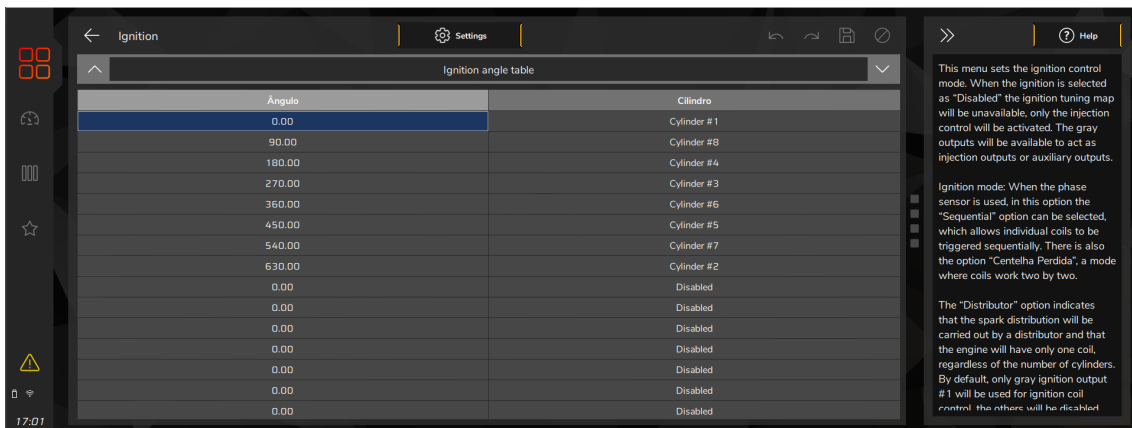

The last step of the ignition setup is to adjust the Dwell table by battery voltage.

- 1 - Navigation bar
- 2 - Multiple selection button

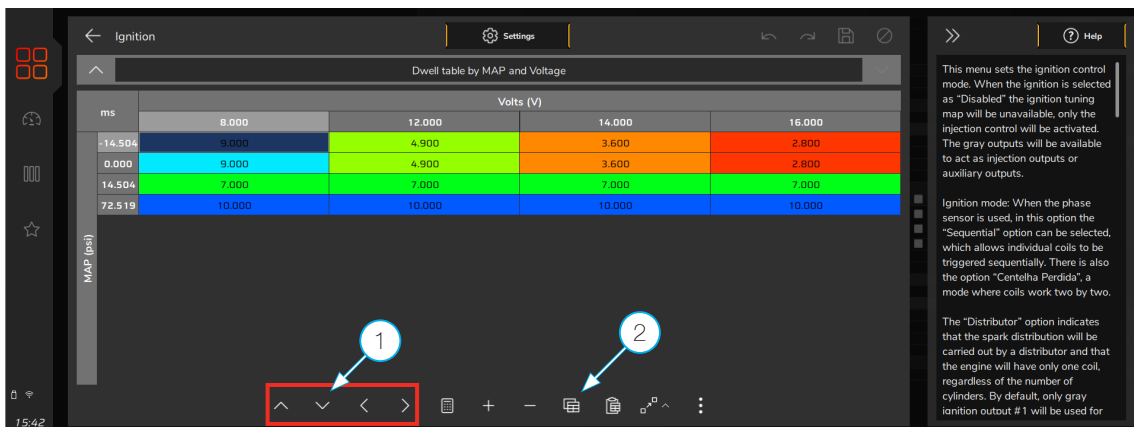

## 7.5 Fuel injection

In this menu, all the options related to fuel settings must be configured.

**Fuel primary:** check to able this bank.

**Multipoint:** all the injector's outputs will fire at the same time, as a batch fire. Injectors pulses at 0°.

**Sequential:** in this mode, each injector output fires only a single time per engine cycle (720° on a 4 stroke). This mode is only enabled when a cam sync sensor is properly set up.

**Semi-sequential:** in this mode, injectors are fired twice per engine cycle, in pairs, according to the twin cylinders. In a 4 cylinders engine, cylinders 1 and 4 will be fired at the same time, as will do cylinders 2 and 3.

**Primary output:** define numbers of injectors

**Fuel injectors deadtime:** All fuel injectors, for they are electromechanical valves, have an opening inertia, which means that there is a "dead time", a moment in which the injector has already received an opening signal, but still has not started to inject fuel.

This parameter considers, as a standard value, 1.00ms for high impedance fuel injectors.

For low impedance injectors using Peak and Hold driver, set the deadtime to 0,80ms.

**Primary total flow:** Set here the total flow of primary injectors (sum of all injector's flow of each stage).

### NOTES

*The procedure is exactly the same for the secondary injectors configuration.*

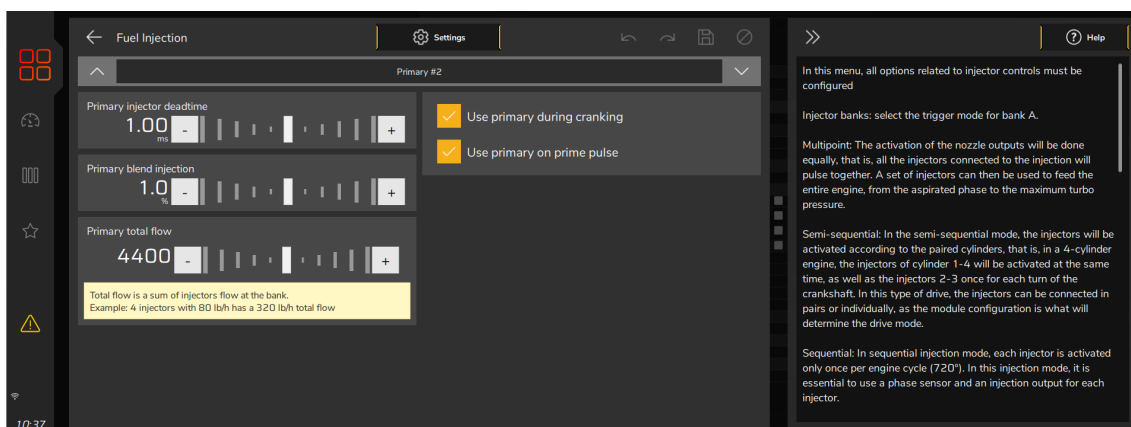
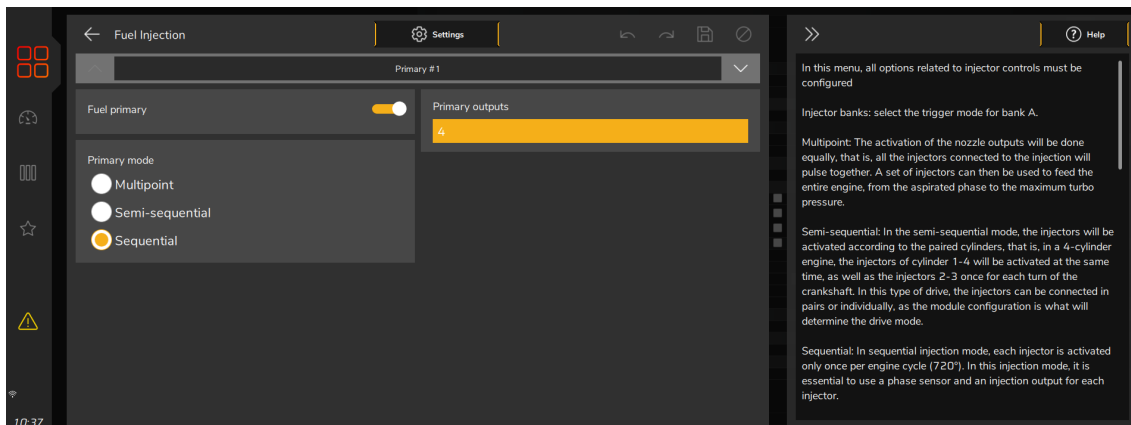

**Disable injection on engine start with TPS above:** A value in percentage of TPS is set so that the injectors are not opened at the engine start, very useful in cases where the car is “Drowned” and it is necessary to remove the fuel from inside of the combustion chamber.

**Injection phase angle:** Select if the “Fuel injection phase angle table” will be based on the injectors opening or closing. The angular distance is the measure between the ignition TDC of each cylinder and the moment the injector should open or close.

**Fuel injector opening:** in this option it is only possible to know the angle the injector will open, but, its closing will varies according to injection time and RPM, this means that, depending on this factors, the fuel injection may still be occurring even after the intake valve closure.

**Fuel injector closing (default):** that’s the commonly used option, cause, the fuel injection always occurs before the end of the intake cycle, no matter the injection time or RPM.

**Fuel type:** Configures which fuel is being used, changing this field the injection map tables and the compensations will be recalculated for the new type of fuel.

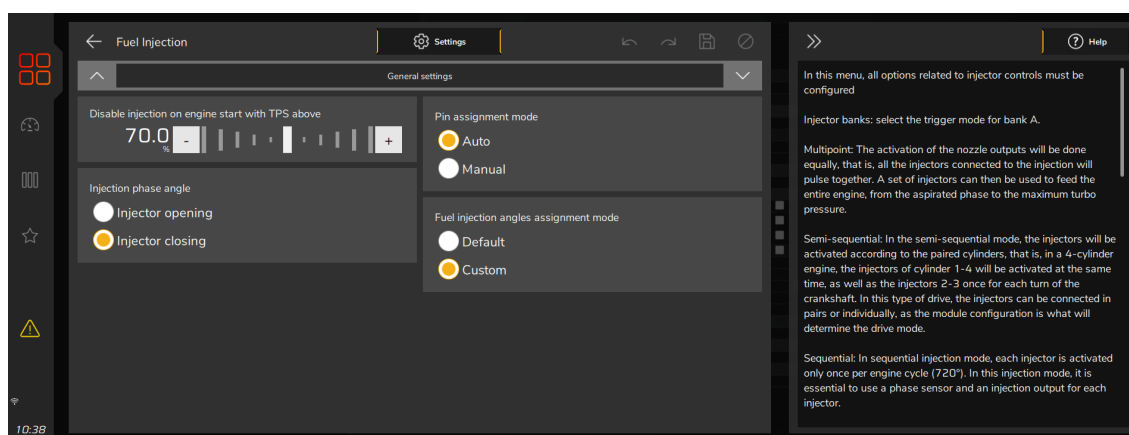

**Fuel injection angle table:** After generating a base map, sending it to the VCU and reading it back, the fuel injection angle table is automatically filled (angle x cylinder). In case you want to edit the angle table manually, select the Advanced mode under Fuel injection angles assignment mode, right above the fuel injection angles table.

Ángulo	Cilindro	Bancada
0.00	Cilindro #1	Primary
90.00	Cilindro #8	Primary
180.00	Cilindro #4	Primary
270.00	Cilindro #3	Primary
360.00	Cilindro #6	Primary
450.00	Cilindro #5	Primary
540.00	Cilindro #7	Primary
630.00	Cilindro #2	Primary
0.00	Cilindro #1	Secondary
90.00	Cilindro #8	Secondary
180.00	Cilindro #4	Secondary
270.00	Cilindro #3	Secondary
360.00	Cilindro #6	Secondary
450.00	Cilindro #5	Secondary
540.00	Cilindro #7	Secondary

In this menu, all options related to injector controls must be configured

Injector banks: select the trigger mode for bank A.

Multipoint: The activation of the nozzle outputs will be done equally, that is, all the injectors connected to the injection will pulse together. A set of injectors can then be used to feed the entire engine, from the aspirated phase to the maximum turbo pressure.

Semi-sequential: In the semi-sequential mode, the injectors will be activated according to the paired cylinders, that is, in a 4-cylinder engine, the injectors of cylinder 1-4 will be activated at the same time, as well as the injectors 2-3 once for each turn of the crankshaft. In this type of drive, the injectors can be connected in pairs or individually, as the module configuration is what will determine the drive mode.

## 7.6 Pedal/Throttle

Select the option “TPS” when using a mechanical throttle, driven by cable.

**TPS:** When using a cable-actuated throttle, with a TPS sensor (potentiometer) on the throttle body, select the “TPS” option. The standard input for the TPS sensor signal is white n° 11, however it is possible to configure it in another input if necessary. Pedal calibration should be performed as indicated in section “15.5 Calibrating the electronic pedal/throttle” on page 73 of the manual.

**Electronic throttle control – ETC:** First data to be inserted on the VCU when using electronic Throttle is its code (not the throttle part number). This code is found on the flash drive provided with the VCU.

**Two electronic throttle:** Configures two electronic throttle. When using two throttle, they must be the same (with the same Part Number).

**Drive by wire protection:** option that turns throttle motors off with engine off, preventing throttle wear and overheating.

## ETC

**Predefined:** Uses a throttle that already has a record in the FuelTech database

**Custom:** These parameters should only be used when instructed by FuelTech Technical Support.

## NOTES

*If your throttle is not listed on this document, please, contact our tech support to check compatibility first.*

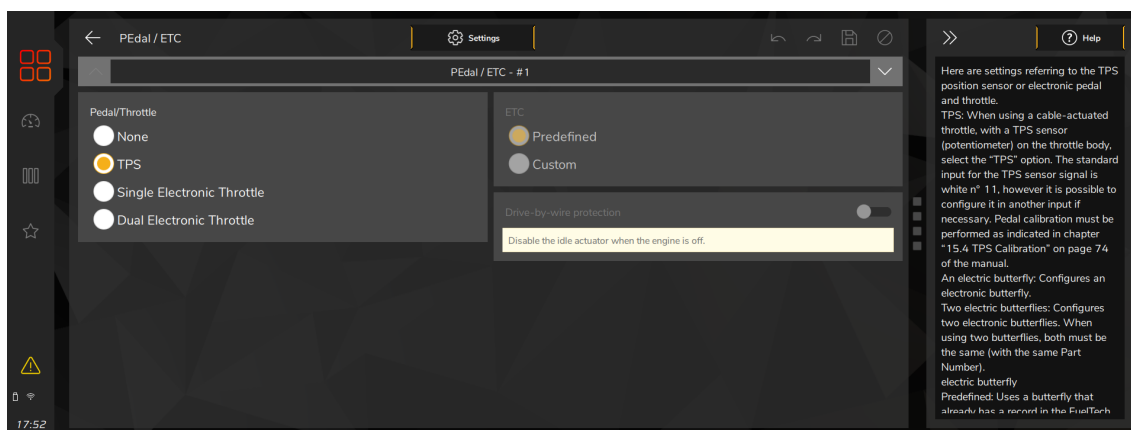

## Predefined ETC

**Brand:** Select the manufacturer of the ETC.

**Model:** Select the ETC model.

**Description:** description of the ETC and its application.

**Code:** Automatically generated by Vision FuelTech software based on the throttle’s working PID.

## Custom electronic throttle

These parameters are to be used only when directed by FuelTech Technical Support.

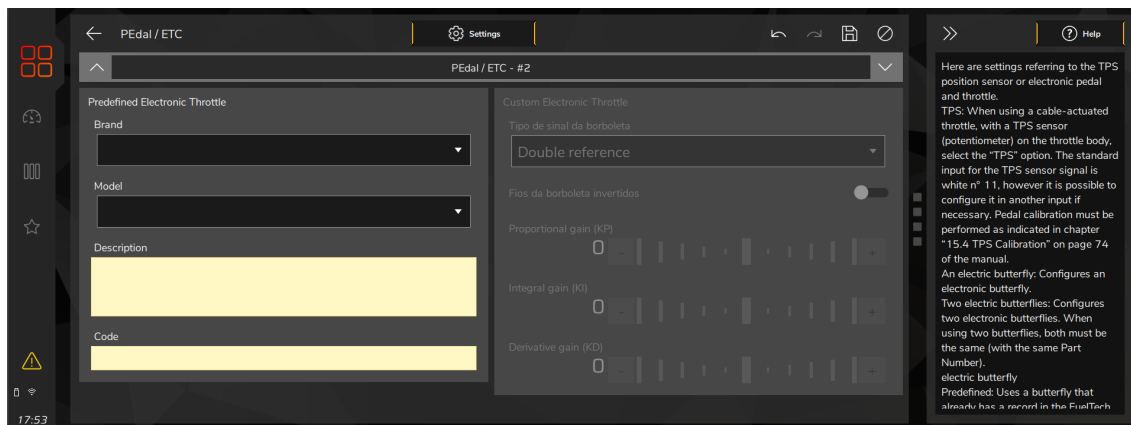

## Throttle speed

There are five control modes.

**Normal:** normal throttle response little bit faster than the stock VCU.

**Fast:** fast throttle response.

**Smooth:** smoother control mode, used on street cars and automatic transmissions.

**Smooth when cold and Normal when hot:** changes the control mode according to the engine temperature, starts with smooth mode, and then changes to normal mode automatically.

**Smooth when cold and Fast when hot:** changes the control mode according to the engine temperature, starts with smooth mode, and then changes to normal mode automatically.

## Pedal mode

This parameter changes the ratio between the pedal and the throttle.

**Linear:** recommended for street cars.

**Progressive:** this mode has a 1:1 ratio between pedal and throttle. Recommended for cars equipped with manual gearboxes.

**Aggressive:** throttle/pedal ratio is 2:1. When pressing 50% pedal, throttle is already on 100%. Used on vehicles equipped with automatic gearboxes.

**Custom:** it is possible to customize Pedal/Throttle reference table.

**Custom pedal position and RPM:** Option to configure throttle opening curve according to gear and engine RPM.

**Throttle opening limit:** The last parameter to be configured is an opening limiter, very useful to limit the engine power by the throttle. Use 100% when no safety limit is wanted.

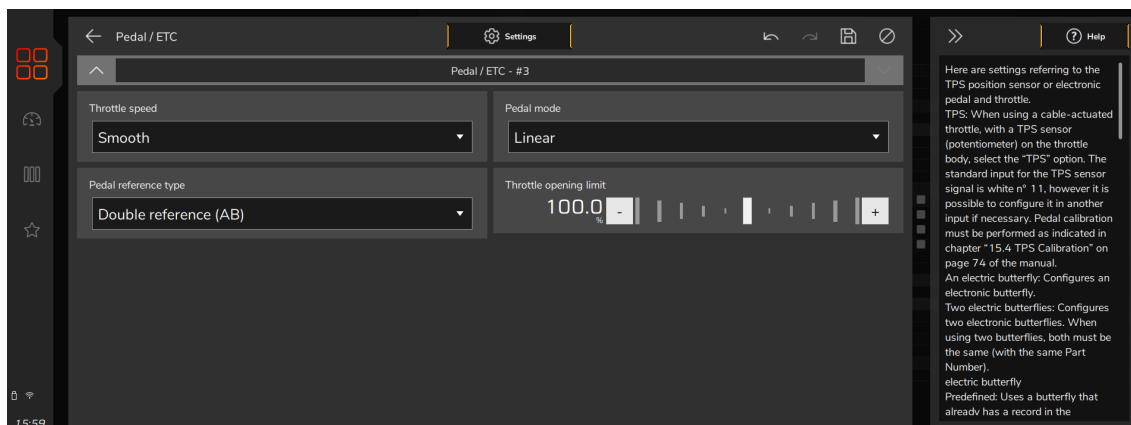

## 7.7 Idle actuators

This menu allows you to select the idle actuator used on the engine and the outputs that will control it. After this quick setup, the idle speed parameters must be done according to chapter 19.2. An important tip is that, when selecting “No Actuator”, it is still possible to control idle speed by ignition timing as configured in the “Other Functions” then “Idle Speed” menus. If any kind of actuator is selected, the idle speed by timing control is automatically enabled. This happens because the idle speed control was specially developed for this FT, integrating the timing control with the actuator reactions

**Electronic throttle:** Select this option, then go to “Idle speed control settings”, under “Other Functions” menu. Check Chapter 19.2 of this manual for more details.

**Stepper motor:** In this option, the four yellow outputs are used. It is necessary to inform which output controls which step motor output and the step motor type. There are predefined actuators for VW and GM models (number of steps) and a “Custom” mode that allows the configuration of steps. As there are many variables in the manufacturing process, if you’re experiencing difficulties at idle tuning, check the “Custom” mode and change the number of steps. In some GM step motors, 190 is the correct number. For some VW step motors, 210 works better. The option “Fully open for TPS over 90%” fully opens the idle valve when TPS is above 90%, increasing the air admitted.

**PWM Valve:** After selecting this option, it will be necessary to set up the output connected to the valve and the control frequency. Small valves usually use up to 2000Hz. For big valves use around 100Hz. If your valve becomes noisy, that means the control frequency is lower than what the valve requires. In this case, increase the control frequency. Be aware that the only outputs that can control these kinds of valves are the yellow ones.

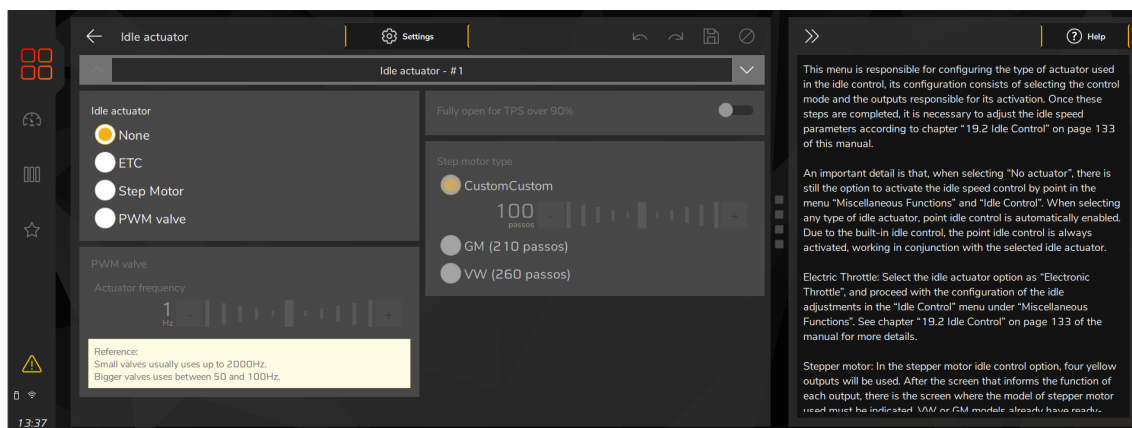

**Idle actuator protection:** after 2s with the engine off, the idle actuator outputs will be disabled. Once the VCU has RPM signal, the actuator is powered again and stays on cranking position.

**Turn off stepper motor when the target position is reached:** Turns off stepper motor power supply to reduce heating

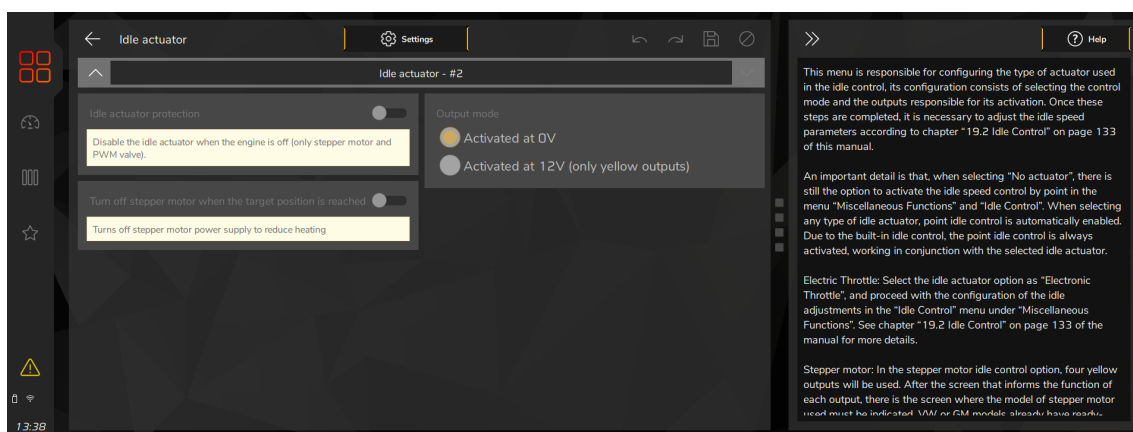

## 7.8 Fuel configuration

This function allows you to configure the type of fuel used in the vehicle. This option is only available if the injection strategy is selected as “*Injector Pulsewidth*”. With this configuration, it is possible to calculate fuel consumption, providing data such as instantaneous consumption, average consumption and vehicle autonomy.

- Ethanol: 0.809 g/cm<sup>3</sup>
- Gas station gasoline: 0.730 g/cm<sup>3</sup>
- Competition gasoline: 0.715 g/cm<sup>3</sup>
- Methanol: 0.792 g/cm<sup>3</sup>

**Atmospheric pressure:** Adjusts the ATM value.

**BSFC:** Used to calculate engine power from fuel consumption. The BSFC index to be configured represents a calibration factor depending on the fuel used, engine type, engine efficiency and ignition and mixture settings.

**AFR scale:** allows you to adjust which fuel will be used.

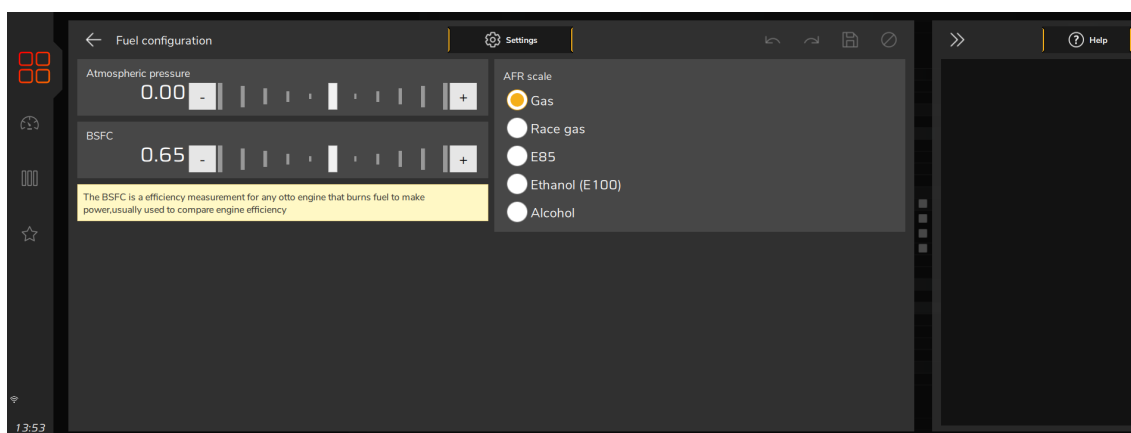

## 7.9 Injector Configuration

This function allows you to configure the injectors installed in the engine. This option is only available if the injection strategy is selected as “*Based on VE*”.

**Primary injector flow rate:** Allows you to configure the injector flow rate in cubic centimeters per minute (cc/min).

**Primary injector pressure:** Adjusts the fuel pressure for the injector bank.

**Primary injector regulated pressure:** Adjusts the base pressure for the injector bank.

**Primary fuel pressure:** Defines where the fuel pressure will come from. There are two options: “*Regulator manifold reference*” or “*Regulator Atmospheric reference*”.

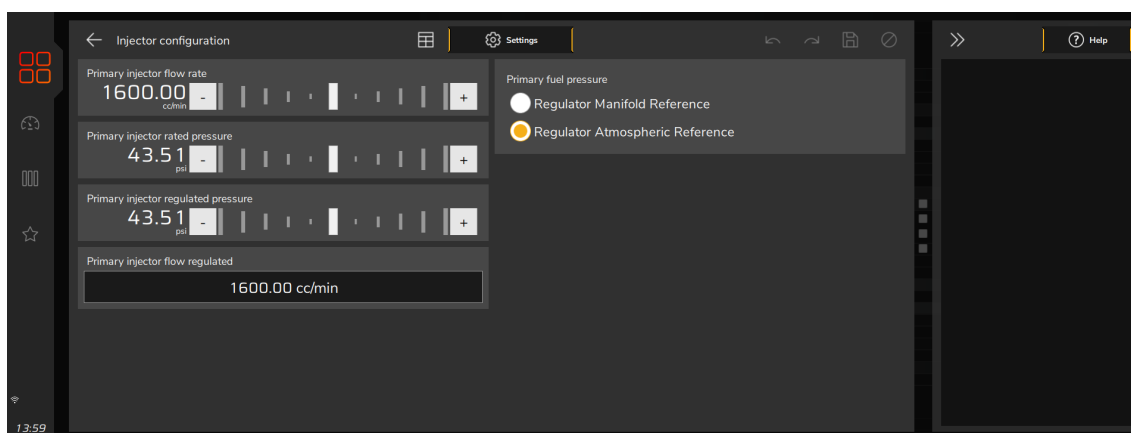

## Adjusts

**Primary injector offset:** Allows you to create a pressure x voltage table to create a time offset for each injector bench.

**Primary injector linearization:** Creates an injector x time table to adjust the opening percentage of each injector based on time.

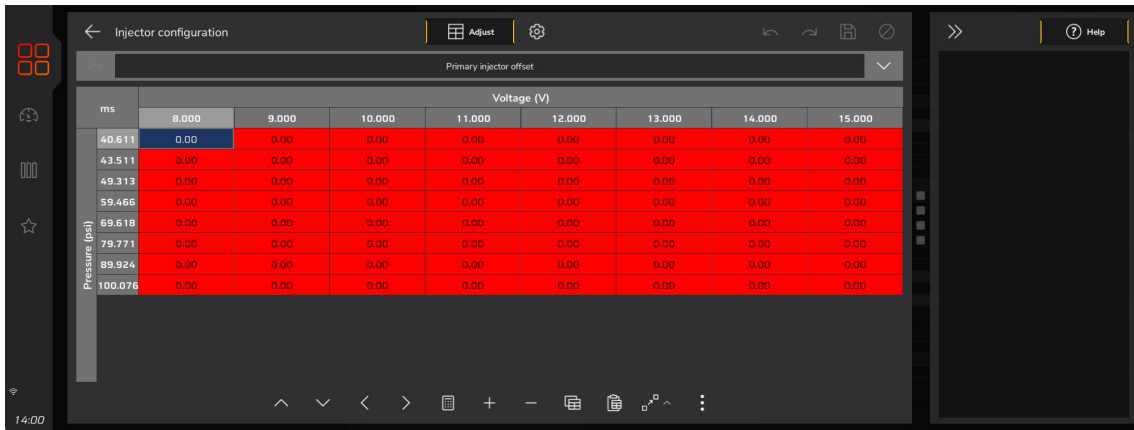

		Voltage (V)								
		8.000	9.000	10.000	11.000	12.000	13.000	14.000	15.000	
Pressure (psi)	ms	40.611	0.00	0.00	0.00	0.00	0.00	0.00	0.00	0.00
	43.511	0.00	0.00	0.00	0.00	0.00	0.00	0.00	0.00	0.00
	49.313	0.00	0.00	0.00	0.00	0.00	0.00	0.00	0.00	0.00
	59.466	0.00	0.00	0.00	0.00	0.00	0.00	0.00	0.00	0.00
	69.618	0.00	0.00	0.00	0.00	0.00	0.00	0.00	0.00	0.00
	79.771	0.00	0.00	0.00	0.00	0.00	0.00	0.00	0.00	0.00
	89.924	0.00	0.00	0.00	0.00	0.00	0.00	0.00	0.00	0.00
	100.076	0.00	0.00	0.00	0.00	0.00	0.00	0.00	0.00	0.00

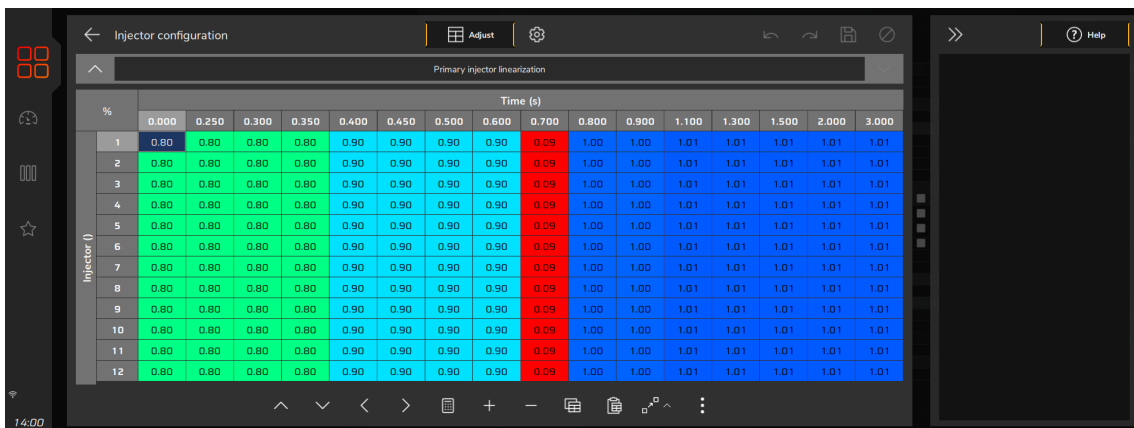

		Time (s)																
		0.000	0.250	0.300	0.350	0.400	0.450	0.500	0.600	0.700	0.800	0.900	1.100	1.300	1.500	2.000	3.000	
Injector (1)	%	1	0.80	0.80	0.80	0.80	0.90	0.90	0.90	0.90	0.09	1.00	1.00	1.01	1.01	1.01	1.01	1.01
	2	0.80	0.80	0.80	0.80	0.90	0.90	0.90	0.90	0.09	1.00	1.00	1.01	1.01	1.01	1.01	1.01	1.01
	3	0.80	0.80	0.80	0.80	0.90	0.90	0.90	0.90	0.09	1.00	1.00	1.01	1.01	1.01	1.01	1.01	1.01
	4	0.80	0.80	0.80	0.80	0.90	0.90	0.90	0.90	0.09	1.00	1.00	1.01	1.01	1.01	1.01	1.01	1.01
	5	0.80	0.80	0.80	0.80	0.90	0.90	0.90	0.90	0.09	1.00	1.00	1.01	1.01	1.01	1.01	1.01	1.01
	6	0.80	0.80	0.80	0.80	0.90	0.90	0.90	0.90	0.09	1.00	1.00	1.01	1.01	1.01	1.01	1.01	1.01
	7	0.80	0.80	0.80	0.80	0.90	0.90	0.90	0.90	0.09	1.00	1.00	1.01	1.01	1.01	1.01	1.01	1.01
	8	0.80	0.80	0.80	0.80	0.90	0.90	0.90	0.90	0.09	1.00	1.00	1.01	1.01	1.01	1.01	1.01	1.01
	9	0.80	0.80	0.80	0.80	0.90	0.90	0.90	0.90	0.09	1.00	1.00	1.01	1.01	1.01	1.01	1.01	1.01
	10	0.80	0.80	0.80	0.80	0.90	0.90	0.90	0.90	0.09	1.00	1.00	1.01	1.01	1.01	1.01	1.01	1.01
	11	0.80	0.80	0.80	0.80	0.90	0.90	0.90	0.90	0.09	1.00	1.00	1.01	1.01	1.01	1.01	1.01	1.01
	12	0.80	0.80	0.80	0.80	0.90	0.90	0.90	0.90	0.09	1.00	1.00	1.01	1.01	1.01	1.01	1.01	1.01

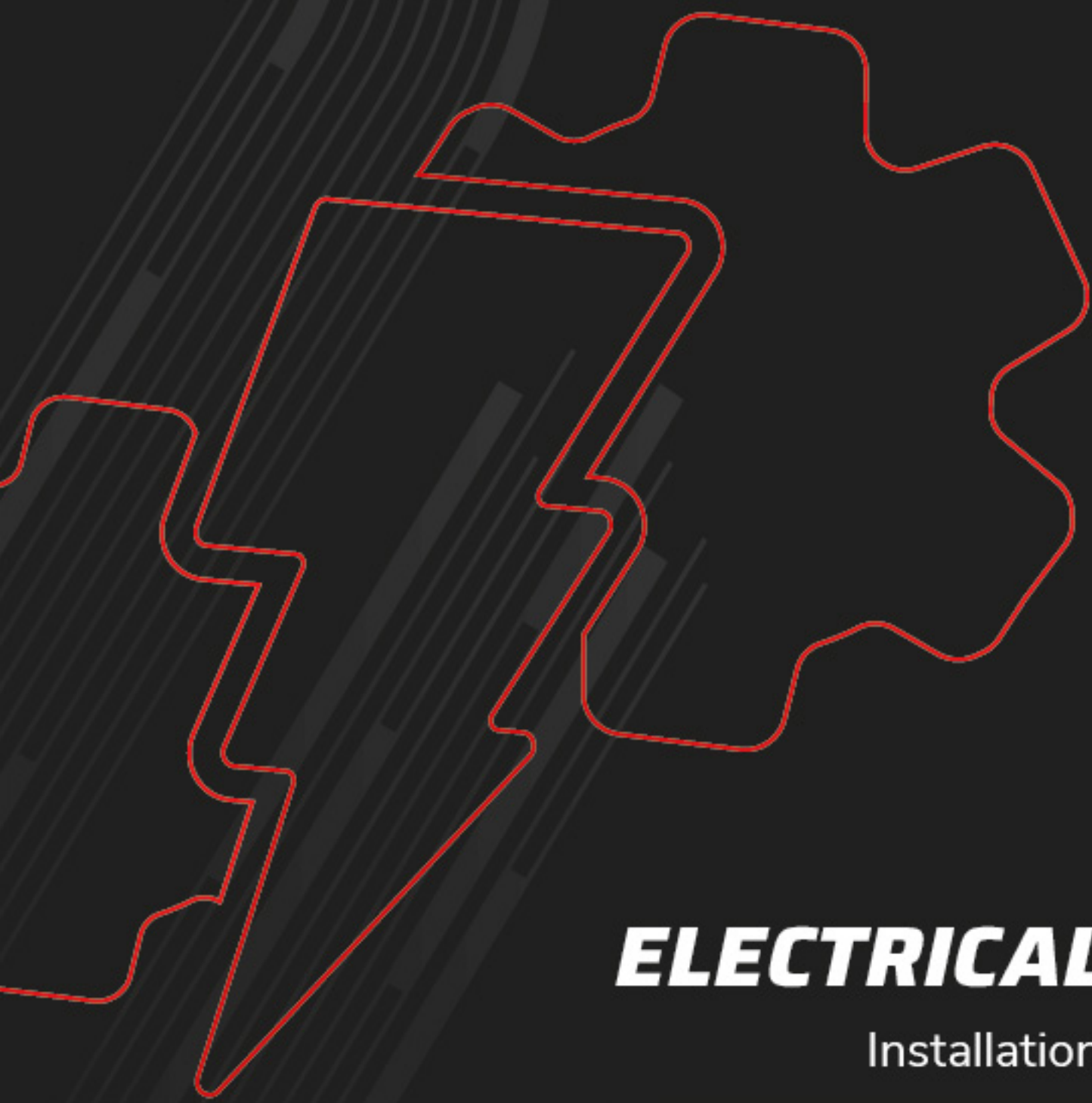

# ***ELECTRICAL***

Installation



## 8. Electrical installation

FT wires are fully configurable according to the installation needs, it is very important that the step by step guide shown on chapter 5 is followed before starting the electrical installation. This way the wiring harness connection table is automatically filled as shows the example below:

The inputs and outputs of the VCU are automatically allocated. To check the inputs and outputs, through the software or the interface, go to the menu “My VCU” and then “Inputs” or “Outputs”.

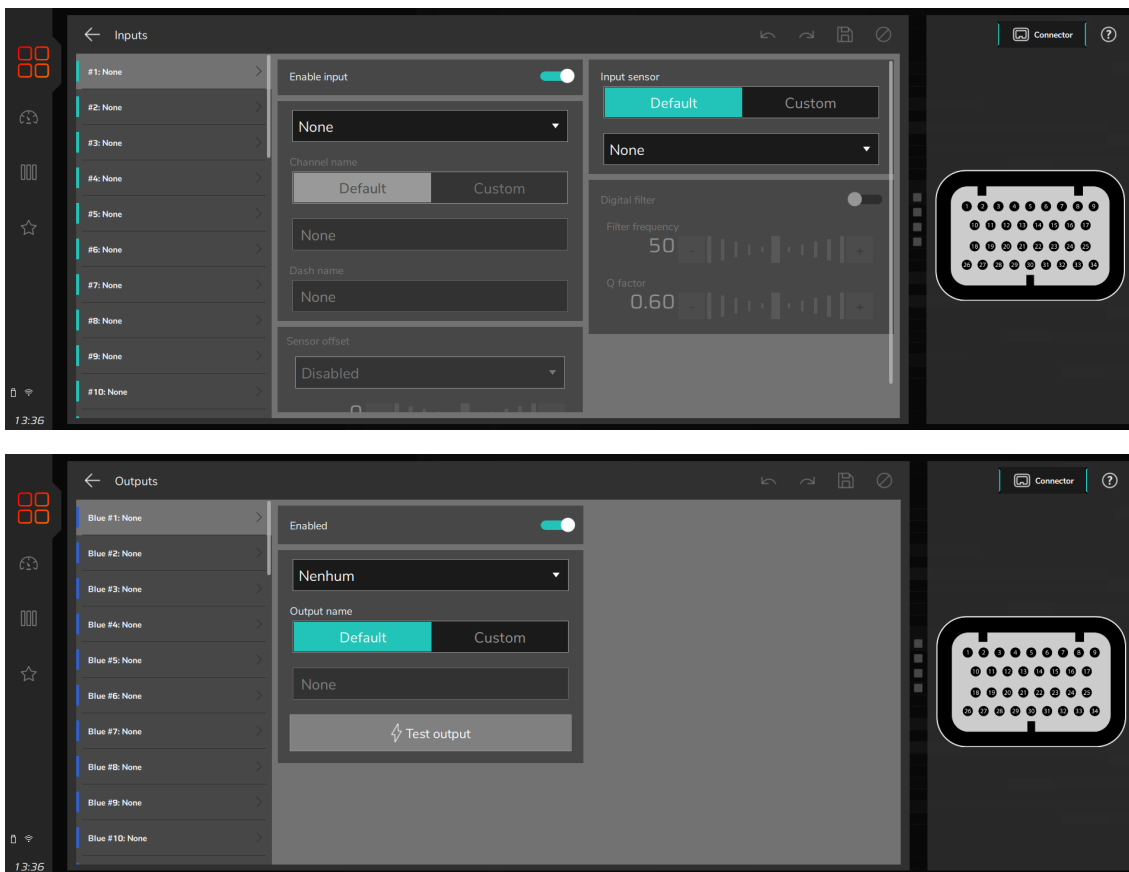

Based on this information, you can start the electrical installation that must be done with the VCU disconnected from the harness and the battery disconnected from the vehicle. It is very important that the harness length is as short as possible and that unused parts of wires are cut off.

Choose an appropriate location to mount the module inside the car, and avoid passing the harness wires close to the ignition wires and cables, ignition coils and other sources of electric noise.

**DON'T EVER**, under any circumstance, install the VCU near ignition modules in order to avoid the risk of interferences.

Harness wires must be protected from contact with sharp edges on the vehicle's body that might damage the wires and cause short circuits. Be particularly attentive to wires passing through holes, and use rubber grommets/ protectors or any other kind of protective material to prevent any damage to the wires. At the engine compartment, pass the wires through places where they will not be subject to excessive heat and will not obstruct any mobile parts in the engine.

### Red wire - 12V input

The 12V input to FuelTech VCU, this wire must be connected to 12V from a relay (Main Relay) and cannot be shared with the positive wire that powers coils, fuel injectors or other actuators.

- **12V for sensors:** use a 22 AWG wire from the same 12V wire that feeds the VCU (Main Relay). Example: Hall Effect sensors, speed/ driveshaft RPM sensors, etc. This wire cannot be shared with the positive wire that powers coils, fuel injectors or other actuators.

- **12V for fuel injectors:** use a 14-16 AWG wire connected to a 40A relay. Protection fuse must be chosen according to the peak current of the fuel injectors Plus a 40% safety coefficient. Example: for 4 injectors that draw 1A of current

per injector on primary bank, and 4 injectors that draw 4A of current per injector on secondary bank:  $(4 \times 1A) + (4 \times 4A) = 20A + 40\% = 28A$ . Use a 30A fuse.

- **12V for coils, fuel pump and other high power actuators:** use a wire appropriately sized connected to a relay and a fuse sized according to the device's current draw. When using individual coils (COP), it is recommended to use a 40A relay per 4 coils.

**NEVER** share the 12V that feeds injectors, coils or other accessories, because, after shutting the engine off, there is a risk of reverse current that may damage a sensor or the ECU.

### Black wire - Battery's negative

This wire is responsible for signal ground to the VCU, so it must be connected straight to the battery's negative terminal, with no seams. Under no circumstances, should this wire be connected to the vehicle chassis or split with the VCU black/white wire (power ground). This will cause electromagnetic interference and other problems hard to diagnose and solve.

The black wire must have permanent contact with the battery's negative terminal, never being connected to switches, battery shut offs or others. To turn a FuelTech VCU on and off, the 12v feed wire(s) should be switched on and off.

- Attach the negative wires to the battery terminal using ring terminals and avoid soldering them. A well crimped terminal has better resistance than a soldered one. Besides that, solder makes the joint stiffer, and less resistant to vibration, typically found in automotive applications.

- Use a proper crimping tool and insulate the wire with insulating tape or heat shrink tubing.

- If there's a need to solder the wire to the terminal, check its resistance after the solder, it should be lower than 0.2 Ohms.

**NOTE:** If corrosion is found (green/white powder) on the battery terminals, clean it with a wire brush and baking soda or contact cleaner spray. Double check the terminal holder and replace it if necessary. Check resistance after the cleaning, it should be lower than 0.2 Ohms.

### Green/Black wire - Ground for Strain gauge sensor

This ground should only be used for the strain gauge sensor when the vehicle is using the integrated GearController function. No other sensors should share this grounding point. In this case, a dedicated grounding point must be added for the other sensors.

If the vehicle is not equipped with a strain gauge sensor, this grounding point can be used by other sensors.

### RPM and CAM sensor Cable Shielded (ground) - Precautions

When using Hall effect RPM and CAM sensors, the shielded cable ground cannot be used under any circumstances; it provides protection against electromagnetic noise from motor components.

### Black/White wire - power ground

These are the VCU power ground wires. They **MUST** be wired to the battery's negative terminal. The power ground (black/white wire) can not be joined to the signal ground (black wire) before reaching the battery's negative terminal.

The three power grounds must have permanent contact with the battery's negative terminal. To turn a FuelTech VCU off, the red wire should be switched on and off.

**NOTE:** It is very important to have at least 2 heavy gauge wires that connect the engine block and to the chassis and to the battery. If this cable is defective or undersized, it may cause serious damage to the VCU and its sensors. For this reason, we recommend the use of at least two of these cables.

## Video wires M connector

The VCU has an exclusive connector for connecting video signals, where it is possible to connect up to 2 cameras integrated with the FT700 log, however, to avoid signal interference, it is necessary that the cables are routed away from the ignition and injection wires.

## Main switch installation (optional) - important tips

Main switches have been used for a long time in competition vehicles for safety purposes in case of an accident.

Just like any other electric accessory, there's a correct way to install it:

The main switch cannot be connected to ground or power ground, under any circumstances!! This is the most common error by installers and can require hours of work to fix all the problems that it can cause, and also a large possibility of damaging all the electronic accessories on the vehicle.

The main switch must ALWAYS control the battery's positive (12V).

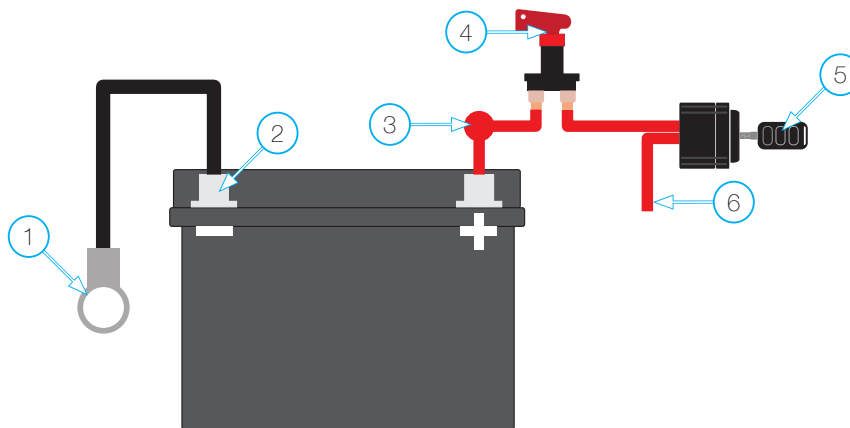

- 1 - Ground connecting battery negative to chassis and engine
- 2 - The ECU's black, and black/white wires must go straight to the battery's negative terminal without being joined together along the way
- 3 - Positive wire to alternator (if applicable)
- 4 - Main switch
- 5 - Ignition Switch
- 6 - Switched 12V



# ***WIRING POWERFT ECUS***

to harnesses from previous ECUs



## 9. Wiring PowerFT ECUs to harnesses from previous ECUs

To install the FT700 and FT700Plus modules, it is possible to use the existing installation of FT450, FT550/LITE and FT600 products together with an adapter harness (sold separately). This way, it is not necessary to redo the electrical harness.

The best option is to perform a new installation, with the FT harness, according to the recommendations contained in this manual. This eliminates the possibility of poor contact and interference problems, common in installations that have been in use for some time.

However, if the option of installing a new harness is not possible, there is another alternative, by pinning the connectors of the old FT harness according to the instructions in item "4.11 Connector disassembly" on page 22 and connecting them according to the diagrams below.

### ! IMPORTANT

- The wire positions are sequentially numbered in back rear of both connectors. The following diagrams show the connectors from a back view, where the pins must be inserted.
- After migrating the harness to a new FT module, it is necessary to calibrate the ignition timing again. To verify the procedure, refer to the chapter "15.3 Ignition calibration" on page 82 of this manual.

### 9.1 Diagram Connector - FT450 to FT700

Color	Function	FT450 Connector A (PINS)	FT700 Connector A (PINS)	FT700 Connector B (PINS)
Blue	Blue Output - #01	01	01	-
Blue	Blue Output - #02	02	02	-
Blue	Blue Output - #03	03	03	-
Blue	Blue Output - #04	04	04	-
Blue	Blue Output - #05	05	05	-
Blue	Blue Output - #06	06	06	-
Black/white	Power Ground	07	-	18
Gray	Gray Output - #01	08	18	-
Gray	Gray Output - #02	09	19	-
Gray	Gray Output - #03	10	20	-
Gray	Gray Output - #04	11	21	-
Black	Battery negative	12	-	10
Red	Switched 12V	13	-	26
Green/Red	5V sensor	14	-	27
Yellow/Blue	CAN LOW	15	-	11
Red/White	CAN HI	16	-	12
White	CAM signal input	17	-	04
White	Crank reference	18	-	02
Red	Crank signal	19	-	01
White	Input - #01	20	-	05
White	Input - #02	21	-	06
White	Input - #03	22	-	07
White	Input - #04	23	-	08
White	Input - #05	24	-	09
White	Input - #06	25	-	13
White	Input - #07	26	-	14

### Connector A FT700 with PINS FT450

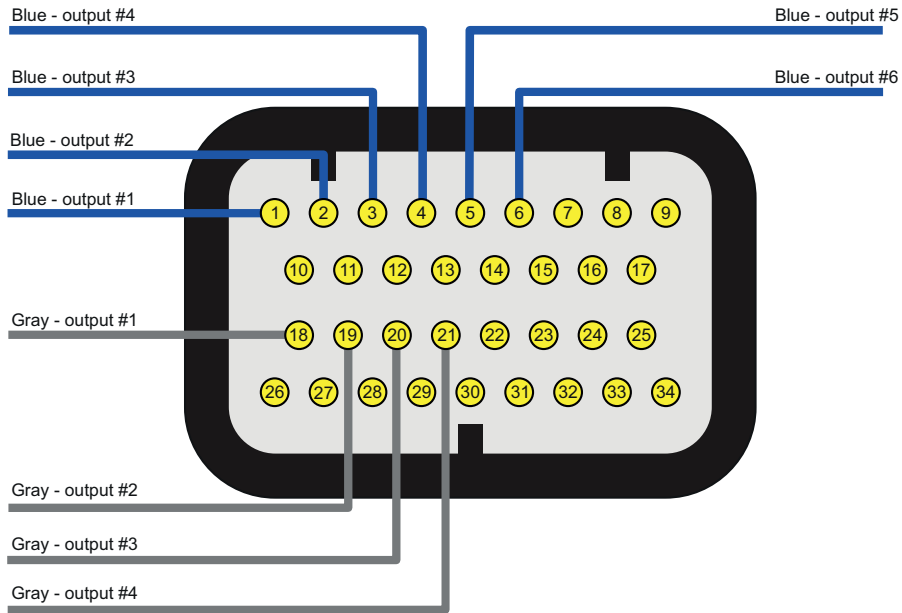

### Connector B FT700 with PINS FT450

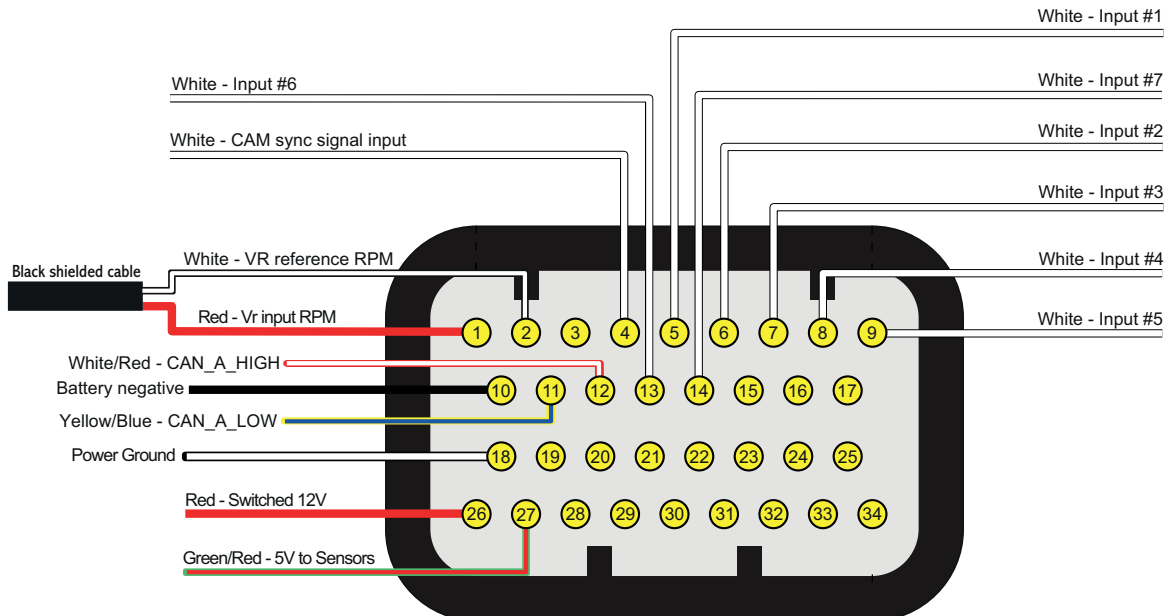

## 9.2 Diagram Connector - FT550 (Connector A) to FT700

Color	Function	FT550 Connector A (PINS)	FT700 Connector A (PINS)	FT700 Connector B (PINS)
Blue	Blue Output - #01	01	01	-
Blue	Blue Output - #02	02	02	-
Blue	Blue Output - #03	03	03	-
Blue	Blue Output - #04	04	04	-
Blue	Blue Output - #05	05	05	-
Blue	Blue Output - #06	06	06	-
Black/white	Power Ground	07	-	18
Gray	Gray Output - #01	08	18	-
Gray	Gray Output - #02	09	19	-
Gray	Gray Output - #03	10	20	-
Gray	Gray Output - #04	11	21	-
Black	Battery negative	12	-	10
Red	Switched 12V	13	-	26
Green/Red	5V sensors	14	-	27
Yellow/Blue	CAN A LOW	15	-	11
Red/White	CAN A HI	16	-	12
White	CAM signal input	17	-	04
White	Crank reference	18	-	02
Red	Crank signal	19	-	01
White	Input - #01	20	-	05
White	Input - #02	21	-	06
White	Input - #03	22	-	07
White	Input - #04	23	-	08
White	Input - #05	24	-	09
White	Input - #06	25	-	13
White	Input - #07	26	-	14

### 9.3 Diagram Connector - FT550 (Connector B) to FT700

Color	Function	FT550 Connector B (PINS)	FT700 Connector A (PINS)	FT700 Connector B (PINS)
Black/white	Power Ground	01	-	19
Black/white	Power Ground	02	17	-
Yellow/Blue	CAN B LOW	03	-	28
Red/White	CAN B HI	04	-	20
White	Input - #08	05	-	15
White	Input - #09	06	-	16
White	Input - 10	07	-	17
Blue	Blue Output - #07	08	07	-
Blue	Blue Output - #08	09	08	-
Gray	Gray Output - #05	10	22	-
Gray	Gray Output - #06	11	23	-
White	Input - 11	12	-	21
White	Input - 12	13	-	22
Blue	Blue Output - #09	14	09	-
Blue	Blue Output - 10	15	10	-
Gray	Gray Output - #07	16	24	-
Gray	Gray Output - #08	17	25	-
White	Input - 13	18	-	23
White	Input - 14	19	-	24
Blue	Blue Output - 11	20	11	-
Blue	Blue Output - 12	21	12	-
Yellow	Yellow Output - #01	22	26	-
Yellow	Yellow Output - #02	23	27	-
Yellow	Yellow Output - #03	24	28	-
Yellow	Yellow Output - #04	25	29	-
Green/Black	Ground for Sensors	26	-	29

### Connector A FT700 with PINS FT550

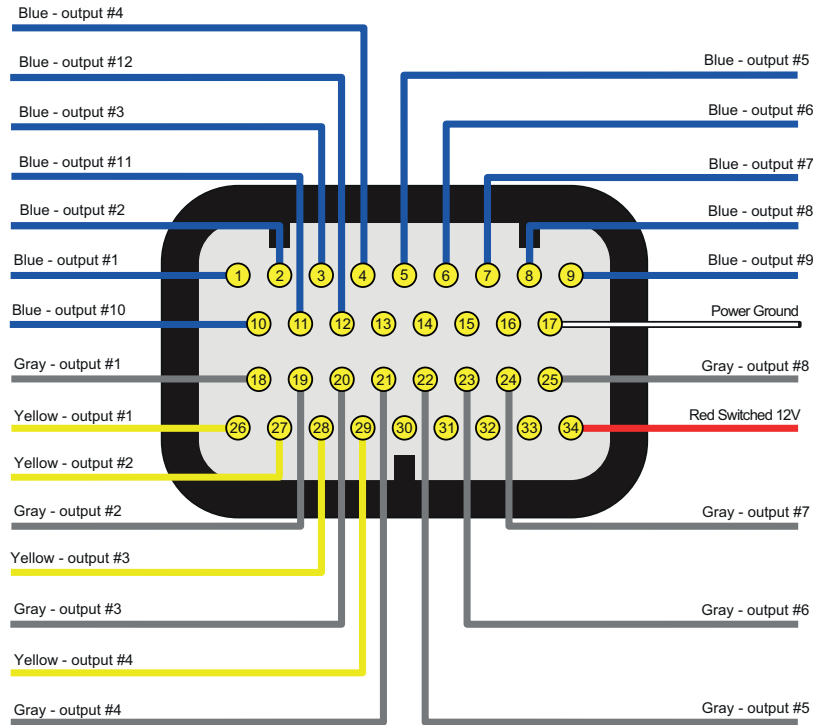

### Connector B FT700 with PINS FT550

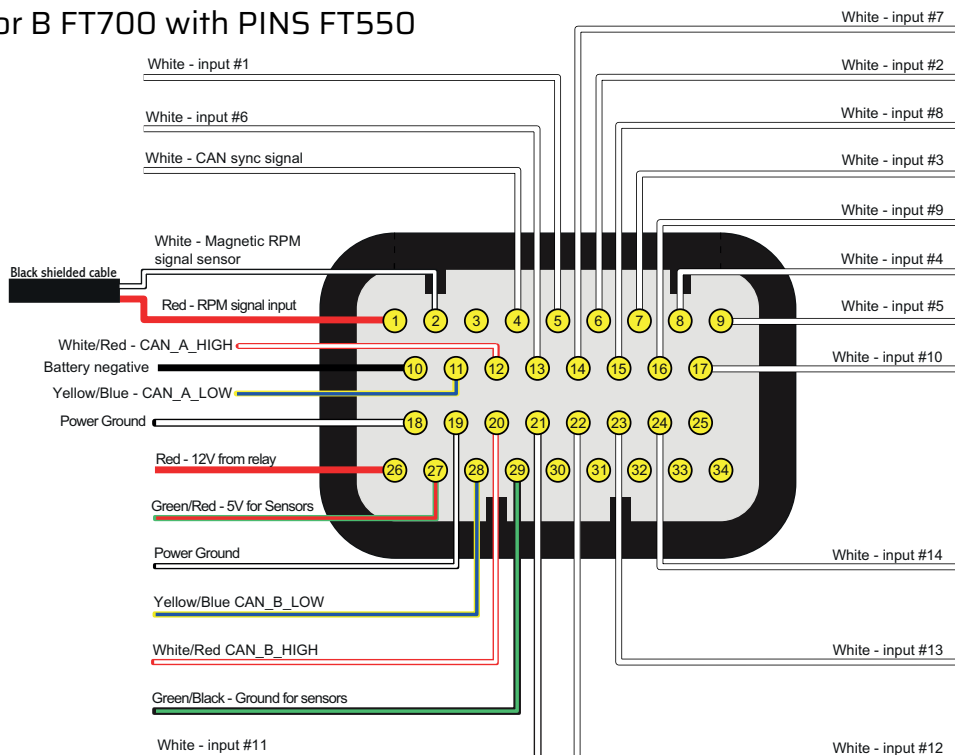

**! IMPORTANT**

The VCU harness is compatible with the FT600 harness, so it is possible to replace the FT600 with an FT700 just by changing the module.

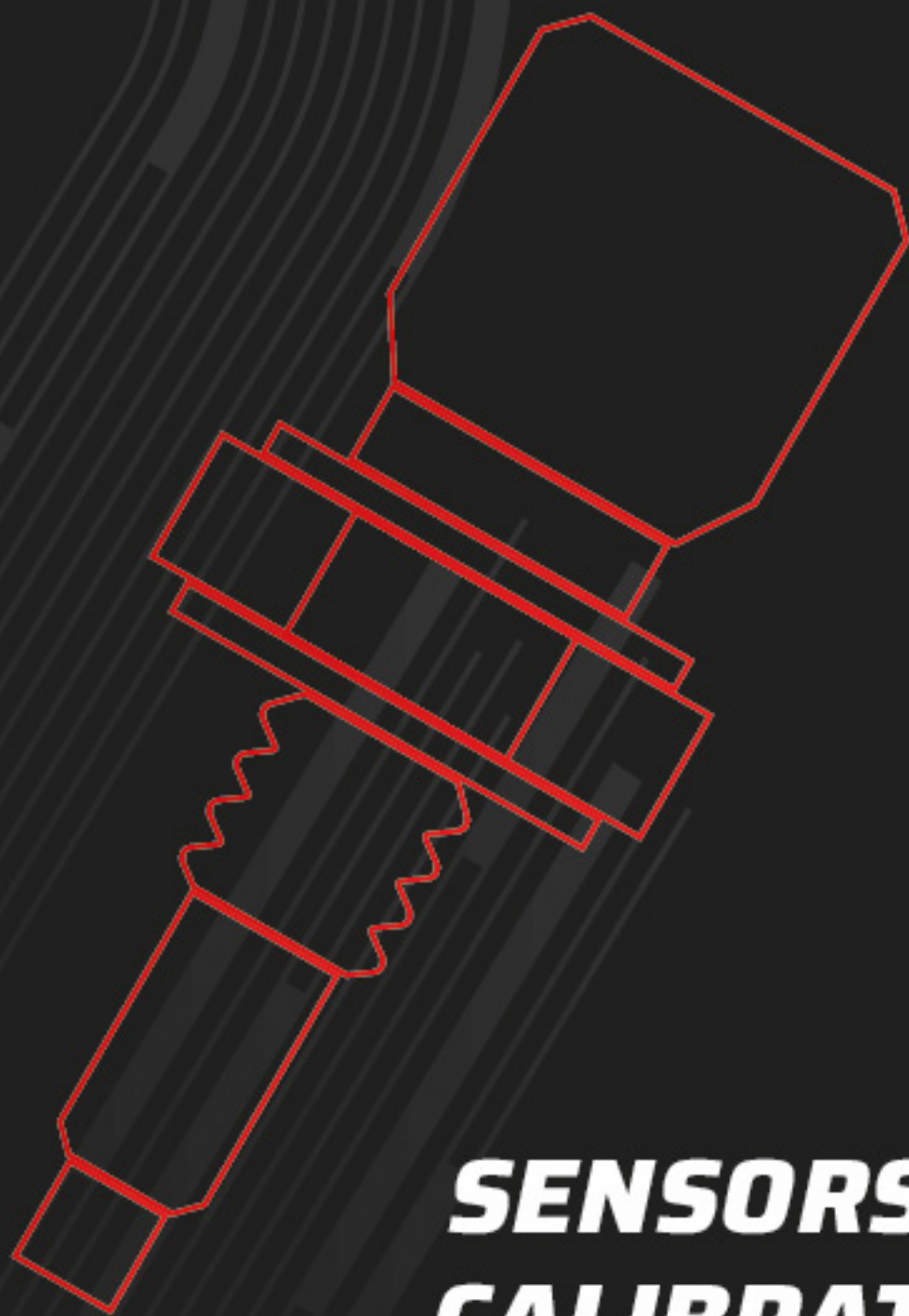

# ***SENSORS AND CALIBRATIONS***



## 10. Fuel injectors

The FT outputs to control fuel injectors (blue wires). Each one of them can control up to 6 injectors with internal resistance above 10 Ohms (saturated injectors) or up to 4 injectors with internal resistance above 7 Ohms. Using a Peak and Hold driver, this capacity varies according to the output and the Peak and Hold current control (2A/0,5A, 4A/1A or 8A/2A).

In situations where more than 16 outputs are needed, the gray or yellow outputs can be set as injector outputs. In this case, the use of a Peak and Hold driver for these outputs is mandatory.

Injectors can be triggered in multipoint, semi sequential or sequential modes.

### Examples of 4-cyl engines running high impedance injectors

- **Individual triggering:** each blue output controls a cylinder. This is the most recommended connection cause is the only one that allows individual per cylinder fuel compensations, amongst other functions.
- **Two injectors per channel:** blue output #1 controls injector of cylinders 1 and 4. Blue output #2 controls injectors of cylinders 2 and 3
- **Four injectors per channel:** use this connection only for compatibility with previous generation FT VCUs. Even with each output controlling only one injector it is possible to change the triggering mode to multipoint (batch fire), semi sequential (outputs triggered in pairs) or sequential.

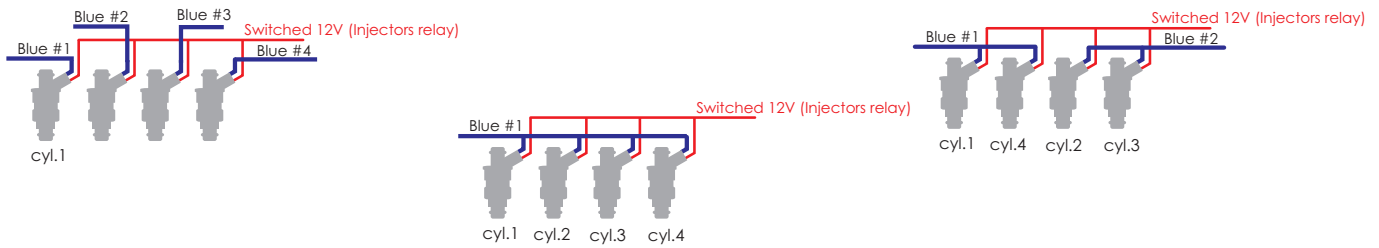

## 11. Ignition

The VCU has ignition outputs that can be used according to the needs of the project, controlling a distributor or a crank trigger.

### Ignition with distributor

When using this VCU with a distributor, the only active ignition output is gray #1. This wire must trigger an ignition module or a coil with integrated igniter. When MSD configured it's utilized Yellow#1.

### Coil with integrated igniter (smart coil)

They are coils with at least 3 pins and only one spark plug wire output. This kind of coil (inductive) must be set as "Falling dwell" in the "Ignition output" menu. In case of selecting the wrong output type, coil will be damaged.

### FuelTech SparkPRO-1 with coil without integrated igniter (dumb coil)

The FuelTech Spark PRO-1 module is a high energy inductive igniter which has an excellent cost/benefit and can be used with any 2-wire dumb coil (without internal igniter). Coils with primary least possible resistance are recommended for maximum SparkPRO-1 potential. The minimum resistance of the coil primary should be 0.3 ohms, below this the SparkPRO will be damaged. Try to place SparkPRO-1 as close as possible to the coil.

## IMPORTANT

*An excessive charging time (Dwell) can damage the SparkPRO and the coil. It is recommended to use a Dwell map with 6ms at 8V, 4ms at 10V, 3.60ms at 12V and 3.00ms at 15V and check coils temperature at the beginning. In the "Ignition" menu, select the ignition output as "Falling dwell". In case of selecting the wrong output type, coil will be damaged.*

### Capacitive discharge ignition module (MSD 6A, MSD 7AL, Crane, Mallory)

FuelTech's ignition output must be connected to the MSD ignition module, (usually, the white wire is the points input). When using a MSD ignition box, the yellow #1 is automatically set up as ignition output.

The installation of ignition modules must always follow what is indicated by its manufacturer in the instructions manual. This ignition module will receive a Points signal from FuelTech. Ignition coil must follow the ignition module manufacturer recommendations as well.

#### Important Notes:

- The module must be placed as close as possible to the ignition coil, and never inside the car, in order to avoid the risk of interference with electronic devices.
- The length of the wires that connects the ignition module to the ignition coil must be as short as possible.
- In "Ignition Setup," select the output "Rise (CDI)".
- It is not possible to control the ignition Dwell when using this type of module.
- To use the ignition cut through MSD, check Chapter 7.3
- When using MSD ignition modules with a distributor, it is necessary to connect a FuelTech white wire to the MSD Legacy input. Doing so improves the response of timing control, which is especially necessary when using Drag Race Features.
- When experiencing problems with the cut through MSD like no cut at all or RPM limit always 500 RPM above what was setup, use the other MSD pin.

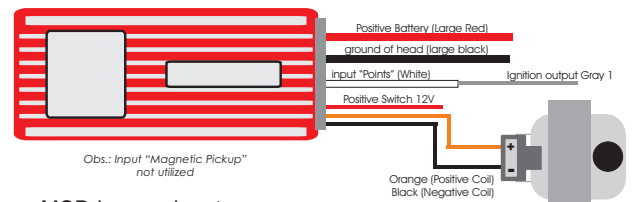

### Ignition with crank trigger

When controlling the ignition in distributor less systems, wasted spark or individual coils per cylinder are needed. In this case, coils are triggered by different outputs, according to the number of cylinders. Ignition outputs (gray wires) are triggered according to the firing order set up on the VCU

Example: 4 cylinder engine with individual coils:

Gray outputs are selected automatically, according to the number of cylinders.

Gray wires that will not be used for ignition control can be set up as injectors outputs (Peak and Hold driver is mandatory) or auxiliary outputs (relay needed).

### Individual coils - electrical connections

These connections must be done by matching the output number with the cylinder number:

- Ignition output #1 controls cylinder #1 coil;
- Ignition output #2 controls cylinder #2 coil;
- Ignition output #3 controls cylinder #3 coil.

When working with dumb coils, an external ignition module must be used (as the FuelTech SparkPRO). In this case, ignition outputs from VCU are connected to the ignition module inputs.

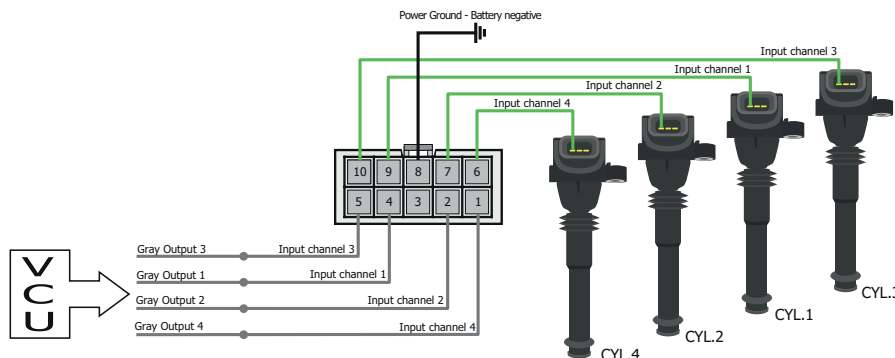

## Wasted spark coils - electrical connections

In this case, ignition output #1 controls cylinder #1 and its twin, ignition output #2 controls cylinder #2 and its twin, etc.

When using dumb coils, an external igniter must be used, such as FuelTech SparkPRO. The FT ignition outputs (gray wires) will be connected to the igniter inputs and the igniter outputs will be connected to the coil.

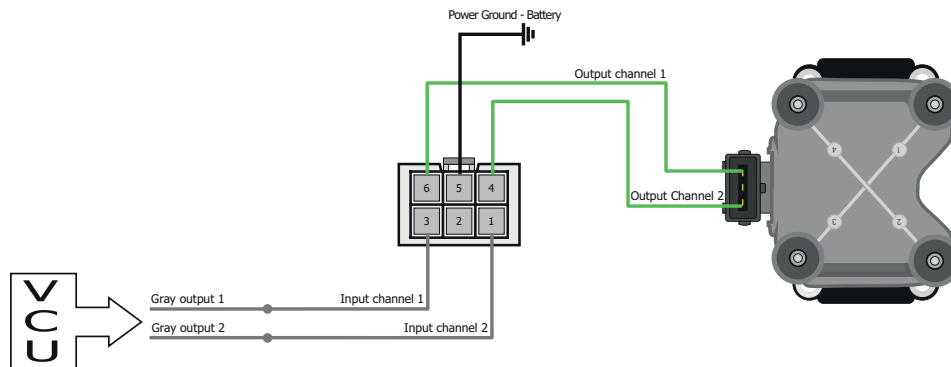

## 12. Sensors and actuators

The VCUs has some pre-defined sensors available as standard, but, it's possible to setup any kind of analog sensor on its inputs or even to connect it and read a sensor in parallel with the OEM VCU. This configuration is done on the custom mode through software FTManager and USB cable on a PC.

### 12.1 Intake air temperature sensor

With this sensor, the VCU can monitor the intake air temperature and perform real time compensations.

Models:

- Fiat: Delphi / NTK (3,3k $\Omega$  a 20°C);
- GM (American): ACDelco: 213-190 / GM n°25036751.

One of its pins is connected to the battery negative. The other to the white #7 wire (standard – can be changed).

### 12.2 Engine temperature sensor

This sensor is very important for a good running engine, as varying engine temperatures dramatically affect an engine's fuel and timing requirements.

On water cooled engines, place this sensor near the engine head, reading the water temperature. On air cooled engines, install this sensor reading the engine oil temperature.

Models:

- Fiat: Delphi / NTK (3,3k $\Omega$  a 20°C);
- GM (American): ACDelco: 213-928 / GM: 12146312 (or 15326386).

One of its pins is connected to the battery negative. The other to the white #5 wire (standard – can be changed).

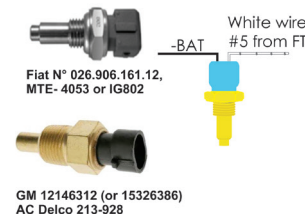
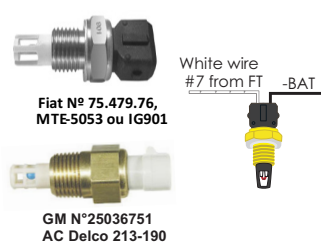

### 12.3 Fuel and oil pressure

FuelTech PS-150/300/1500 is a high precision sensor responsible for general pressure readings (fuel, oil, boost, exhaust back pressure, etc.)

It can be purchased Online at [www.fueltech.net](http://www.fueltech.net) or from an authorized FuelTech dealer (check the website to locate the dealer nearest to you).

FuelTech PS-150/300/1500 sensor below:

- Connection: 1/8" - 27NPT
- Pressure Range: 0 to 150/300/1500psi
- Power Voltage: 5V
- Output Scale: 0.5-4.5V
- Electric Connector: 3-way Metri Pack 150

Pin A: Battery's Negative

Pin B: 5V supply

Pin C: Output signal

FuelTech part numbers:

5005100020 - 0-150 psi sensor

5005100021 - 0-300 psi sensor

5005100022 - 0-1500 psi sensor



The VCU is fully configurable, practically any automotive pressure sensor can be used – if the voltage x pressure table is known, you can setup through FTManager software.

### 12.4 Throttle position sensor (TPS)

This sensor is a potentiometer installed on the throttle to inform the VCU about its position. If needed, it is possible to run the engine without this sensor, but, it is very important for a fine tuning. When possible, use the OEM TPS. This VCU is calibrate to any kind 0-5V TPS sensor. Anyway, FuelTech products are compatible with any 0-5V TPS sensor, since they have calibration function.

#### Finding connections for TPS sensors

Using a multimeter, select the 20k Ohms range, unplug the VCU harness and leave the ignition off. Put the test probes on 2 different pins of the TPS sensor and then open the throttle. You must find 2 pins that will not make any change to the measure when opening and closing the throttle body. One of these two pins must be connected to a 5V output from the VCU and the other one to the signal ground. The third pin is the TPS signal to the VCU.

The TPS signal voltage should vary according to the throttle opening, with voltage differences higher than 3V between fully closed and wide open throttle.

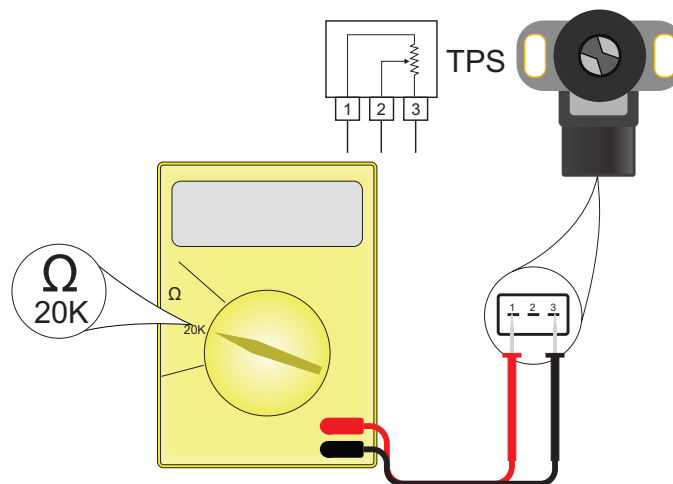

## 12.5 Crank trigger/RPM sensor

To control fuel and ignition, this VCU is able to read magnetic and Hall Effect sensors.

### Distributor

To read RPM signal from a Hall Effect distributor, it should have a sensor with at least 3 pin and have the same number of reading windows (or “triggers”) than the engine has number of cylinders.

VW Hall Effect distributor connections

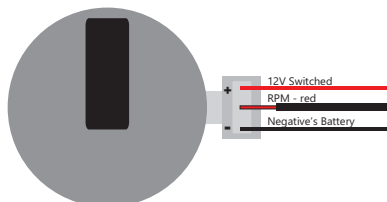

### Crank trigger

The crankshaft trigger wheel is responsible for informing the exact position of the crankshaft to the electronic ignition management system, in such a way that this system is able to determine the ignition timing in the engine. The trigger wheel is installed on the crankshaft, outside or inside the engine block, with a specific alignment. Usually, the Crankshaft Trigger Wheels placed on the outside of the block are put in front of the engine, by the front crankshaft pulley, or in the rear of the engine, by the flywheel. There are many types of Trigger Wheels, but the compatible ones are mentioned below

**60-2:** this is, in general, the most used type of trigger wheel. It is a wheel with 58 teeth and a gap (fault point) equivalent to two missing teeth, therefore called “60-2”. This trigger wheel is found in most Chevrolet (Corsa, Vectra, Omega, etc.), VW (Golf, AP TotalFlex, etc.), Fiat (Marea, Uno, Palio, etc.), Audi (A3, A4, etc.) and Renault (Clio, Scènic, etc.) Models, among other car makers. Ford Flex models with Marelli VCU use this type of trigger wheel also.

**36-2:** standard in Toyota engines, being 34 teeth and a gap equivalent to two missing teeth.

**36-1:** 35 teeth and a gap equivalent to one missing tooth. It can be found in all Ford vehicle lines, with 4 or 6 cylinders (except the Flex models with Marelli injection, which use the 60-2 trigger wheel).

**12 teeth:** this type is used by AEM's Engine Position Module (EPM) distributor. In this case, the CAM sensor from the EPM must be used. This distributor has 24 teeth, but as it rotates half-way for each full engine RPM, there will only be 12 teeth per RPM. Setup the Ignition with 12 teeth at crank (24 at CAM) and the 1st tooth alignment with 60°.

Setup VCU as 12 teeth (at crank) 24 (at cam) and use 60° for 1st tooth alignment.

**Mitsubishi 1G CAS:** due to the fact the CAM signal has two slots on this CAS, it's only possible to control the ignition on wasted spark mode and the fuel injection on multipoint or semi-sequential. No sequential fuel or ignition will work on this CAS with 2 slots on the CAM.

### NOTES

*This crank trigger will only work with a single tooth cam sync. On stock engines it is needed to remove the smaller tooth from the cam trigger wheel.*

## Cam sync sensor:

Not utilized, unless you are running crank trigger and distributor (or a dedicated cam sync sensor) with a single tooth.

**48-2, 30-2, 30-1, 24-2, 24-1, 15-2, 12-3, 12-2, 12-1, 12+1 and 4+1 teeth:** These are less common types, but they are perfectly compatible. These trigger wheels can operate without a camshaft position sensor, as they have a gap that indicates the TDC on cylinder 1.

In order to correctly inform the engine position to the injection module, it is necessary that the injection has the right information about the alignment of the trigger wheel in relation to the TDC on cylinder 1. The image below shows a 60-2 trigger wheel with the sensor aligned on the 15th tooth after gap. In this image, for example, the engine is on the TDC on cylinder 1. Notice that the RPM is clockwise, and therefore, the TDC on cylinder 1 is set 15 teeth after the sensor passes the gap. That is exactly the number of teeth that must be informed to the injection upon its configuration.

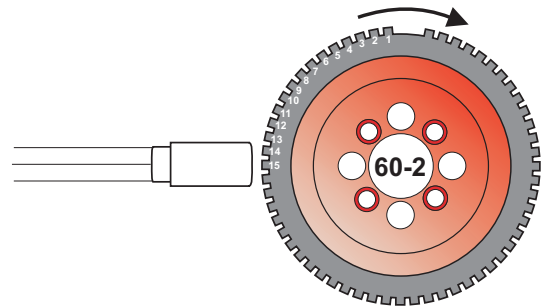

60-2 Trigger Wheel Aligned on the 15th tooth after the gap

Of the space in between them. The minimum diameter for the fabrication of a 60-2 trigger wheel is 125mm (5").

For 36-1 trigger wheels, the minimum diameter recommended is 100mm (4"). Trigger wheels with smaller diameters can be fabricated, but reading errors may occur and the engine may not work.

## Crankshaft trigger sensor

When controlling the ignition with a trigger wheel, it is necessary to have a sensor that reads the signal from its teeth and informs the engine position to the injection. There are two types of crankshaft trigger sensors:

**VR sensor:** this is the type that is most commonly used in cars nowadays, especially with 60-2 and 36-1 trigger wheels. One of its main characteristics is that it does not receive 12V or 5V; it only generates an electromagnetic signal based on induction. It might have 2 or 3 wires (the third wire is an electromagnetic shield).

**Hall Effect sensor:** it is usually found on 2, 3 and 4-tooth trigger wheels and some 36-1 and 60-2 types. It receives a 5V or 12V feed and emits a square wave signal. It invariably has 3 pins: voltage, negative and signal.

## NOTES

*If a VR sensor doesn't pick up RPM signal, try to swap the sensor wires (red and white wires). Or install resistor of 560ohms between red and white wires.*

A very simple test using a tester can identify if a Crankshaft Trigger Sensor is an inductive or a Hall Effect sensor. Turn the tester on the resistance measurement mode at a 2000 $\Omega$  scale and connect its probes to the sensor's pins. Test pin 1 with the other two. If a resistance of 600-1200 $\Omega$  is found, the sensor tested is of inductive type.

If no resistance is found among any of the pins, or if the resistance found is much higher than 1200 $\Omega$ , it is either a Hall Effect sensor, or an inductive sensor with a broken coil. Notice that, when finding the resistance between pins 2 and 3, for example, pin 1 must be connected to the battery's negative terminal and the other 2 to FT shielded cable. If the module does not capture the signal, invert the white and red wires connections.

## 12.6 Camshaft position sensor

This sensor tells the VCU when the cylinder #1 is reaching its TDC on the compression stroke. With this information it is possible to control ignition and fuel injection in sequential mode.

Installation and alignment of this sensor are pretty simple. The only requirement is that this sensor is triggered before the crank trigger sensor goes through the gap on the crank trigger wheel.

## 12.7 O2 sensor

**Wideband O2 sensor:** The use of wideband lambda sensors on VCUs input requires an external conditioner (WB-O2 Slim or WB-O2 Datalogger). It is important to verify the measurement range of conditioner analog output, as this will be informed during the configuration of VCUs O2 input (0,65-1,30, 0,65-4,00 or 0,65 to 9,99)

**Narrowband O2 sensors:** Although less precise than the wideband lambda sensor, narrowband O2 sensors can be connected to the VCU input for the display of values (in Volts) at the Dashboard and at the Diagnostic Panel. Narrowband O2 sensors usually follow a standard set of colors, facilitating the wiring. The table below shows the wiring instructions based on the color scheme generally used for O2 sensor wires:

Wire Color	4-wire O2 sensor	3-wire O2 sensor	1-wire
Black	Signal Output	Signal Output	Signal
White (2 wires)	Switched 12V and ground (connect one wire onto the 12V and the other to ground – there is no polarity)		Not featured
Gray	Battery's negative terminal	Not featured	Not featured

As a general rule, if there are two wires with the same color, one is the switched 12V and the other is the ground. After connecting the O2 sensor to the VCU, the O2 sensor input must be set up as guides chapter 15.5.

## 12.8 Step motor - idle speed

Its control is done through the four yellow outputs of the connector A, also used for electronic throttle control. After selecting the idle speed control as step motor the four yellow outputs are automatically set up as “step motor” on the harness connection table. Below are some known step motor connections.

### IMPORTANT

*Step motor is calibrated every time the VCU is turned on, so, before cranking the engine, it is recommended to wait about 2s after turning the ignition switch on. If this procedure is not respected, the engine may be revved up unwittingly during the step motor calibration, coming back to normal within seconds.*

If your step motor is different from the ones listed here, do what follows:

1. Put a tester on the 200 Ohms range.
2. Measure the step motor actuators until you find a resistance of approximately 50 Ohms. That's one pair of coils.
3. Connect yellow #1 and yellow #3 to a pair of coils and yellow #2 and yellow #4 to the other pair.
4. If the step motor remains fully opened after the calibration, change yellow #1 by yellow #3 position.

FT700 step motor control is compatible with the great majority of actuators nowadays.

Usually, with this simple test you're able to make the step motor work normally.

### 13. Auxiliary outputs

The installation of a fuse equivalent to the charge is recommended. The auxiliary outputs have an overload protection system, with automatic current cut-off. They trigger the charges (lamps, relays, etc.) With a negative signal. Thus, the positive terminal must be connected to a switched 12V.

The auxiliary outputs must be set manually according to the desired function in the outputs (blue, gray or yellow wires) that are not being used as injector or ignition outputs.

In case of having back current and keeping relays switched on with VCU powered off, use a 1N4004 diode.

Each output must be configured in accordance to its function.

For more information about the outputs programming, see chapter 20.

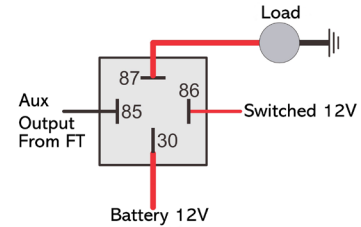

#### 13.1 Cooling fan 1 and 2

This output is responsible for switching an electric fan according to the module's settings. The relay used must be adequate to the electric fan's current (50A, for example). The relay is switched by negative (sourced by the output), and the positive a switched 12V.

**Important Note:** the electric fan must not be connected directly to the auxiliary output without the use of a relay; otherwise, the output will be damaged.

#### 13.2 Idle valve

This function opens a valve which increases the air flow in the intake, helping the engine to idle.

We recommend normally closed valves, such as boost or purge (EVAP) solenoids.

An appropriate relay must be used according to current and voltage. The FT output switches ground and the 12V must be a switched 12V.

#### 13.3 Air conditioning

This auxiliary output option allows for a much more intelligent control of the vehicle's air conditioning compressor, as the FT controls its activation only when the engine is already on and the idle speed has stabilized and turns off the air conditioning when the valve exceeds a predetermined value (a resource commonly used in low-powered engines).

#### A/C button

In order to have the air conditioning control, the A/C button on the dashboard must be connected to a white input of FT. The two connection options are:

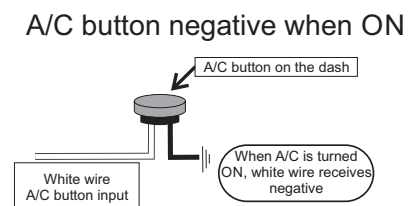
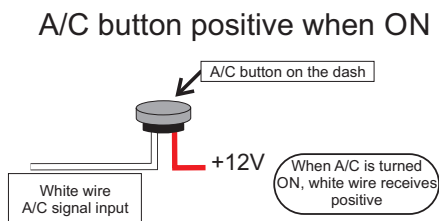

The air conditioning will remain turned on as long as the A/C Signal Input receives signal from the button. The signal polarity can be chosen and it varies depending on the installation.

#### A/C Compressor

A/C compressor must be controlled with a relay, triggered by an auxiliary output (sends negative when activated).

The auxiliary output that was setup as A/C will activate the A/C compressor relay and the A/C fan. For more information on how to setup this output, check chapter 13.

### 13.4 Shift Alert

This function activates an external shift light and works by sending negative when turned on. Any of the options below can be used:

- 12V light: switched 12V directly connected to the light bulb and the negative connected to the blue or yellow outputs.
- LED working as a Shift Light, which must be connected with a serial resistance (if used in 12V, resistance from 390Ω to 1kΩ) to the switched 12V.
- Any “Pen” Shift Light – working in the same way as a light bulb.

### 13.5 Fuel pump

The fuel pump control must be done through a relay sized in accordance to the pump’s working current. The output sends out negative to activate the relay, which stays activated for 6 seconds and turns itself off if the VCU does not receive any RPM signal. When the VCU reads RPM signal, it activates the fuel pump once again.

### 13.6 Variable camshaft control/Powerglide gearbox

The camshaft control systems that use solenoid valve type NO/NC such as Honda’s VTEC can be controlled through this output. The user only needs to inform the solenoid’s turn on RPM.

It is important to notice that the impedance of the variable control system’s solenoid must respect the auxiliary output limits, which requires a minimum impedance of 25Ω, or the use of a relay. For valve timing control systems switched by PWM (such as Toyota’s VVTi), it is possible to manage it through the Boost Control function, as long as its characteristics (power, current, etc.) Are within the auxiliary output limits.

This resource can also be used to switch the control solenoid from the 2-speed automatic gear control, Powerglide type. Configure the RPM to turn on the solenoid responsible for engaging the second gear, only for drag racing applications.

### 13.7 Progressive nitrous control

This function drives the solenoids used for the injection of nitrous oxide in the engine.

As these solenoids have high power (90W) and low impedance (~1.6Ω), they cannot be connected directly to the auxiliary output. A solid state relay with appropriate max current and voltage must be used to power the nitro and fuel solenoids.

Set the output as progressive nitrous output.

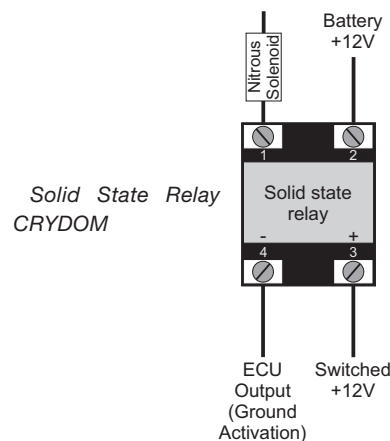
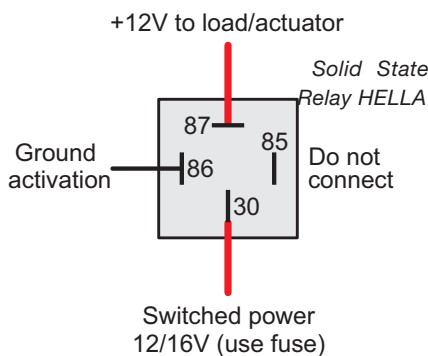

In the second option, the fogger only injects nitrous (dry nitrous). Fuel enrichment is managed by the injection, increasing injection times based on what has been programmed. The dry nitrous system has reached better results in tests, giving the engine a more linear power than the first option. It is important to clarify that in order to use the dry nitrous system, the fuel injectors must be correctly sized for the power maximum with the nitrous system operating.

There is a difference in the operation of solenoids that control nitrous injection and the ones that control fuel injection: nitrous solenoid starts pulsing after 5%; fuel solenoid only pulses after 20%. Variations may occur among solenoids from different brands/manufacturers.

When applying the conventional nitrous control, one must start with a minimum injection time of 20%, but when using dry nitrous, it is possible to start with 5%, as the injectors – and not the solenoid – will control fuel injection.

### 13.8 Boost Control - N75

This auxiliary output configuration allows the driving of a boost pressure control solenoid. FuelTech recommends using a 3-way N75 solenoid, found in the original 4 and 5-cylinder

VW/Audi Turbo models, which can be directly switched through the auxiliary output. Such solenoid valve controls the pressure on the top and bottom parts of the wastegate valve, changing the engine manifold pressure with which the latter opens.



N75 Solenoid Valve  
VW 058-906-283F

#### Wastegate at the exhaust manifold

This type of valve is used on most cars with adapted turbo, in competitions, etc.

Example 1: the first way to install a boost valve is connecting it to the bottom of wastegate valve, similar to the OEM installing in the VW 1.8T. Select the output signal as activated at 0V and frequency at 20Hz.

This way the boost valve will decrease the pressure under the wastegate to increase boost pressure.

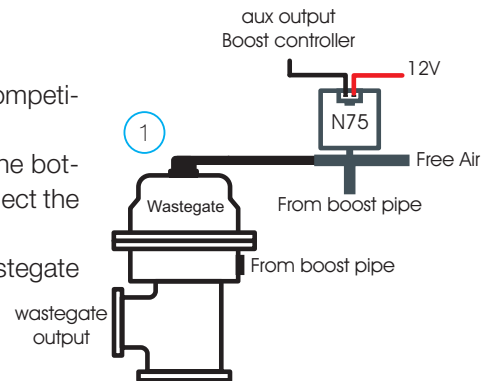

Example 2: the second way is to connect the boost solenoid to the top of wastegate.

Select the output signal as activated at 12V and frequency at 20Hz.

This way, the boost valve will increase the pressure at the top of wastegate to increase boost

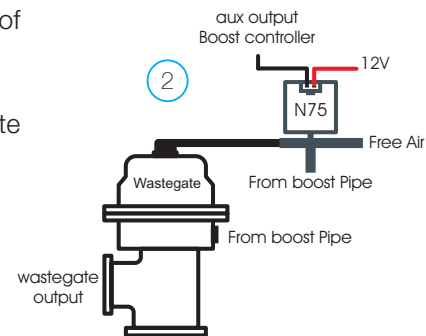

#### Wastegate integrated to the turbine

This valve has a different operation system, as it relieves the boost pressure when pressure is put on its top part, which is the opposite of what happens to the wastegate installed at the exhaust manifold.

Select the output signal as activated at 0V and frequency at 20Hz

With this kind of wastegate, the boost valve relieves the pressure in top of wastegate to increase boost pressure

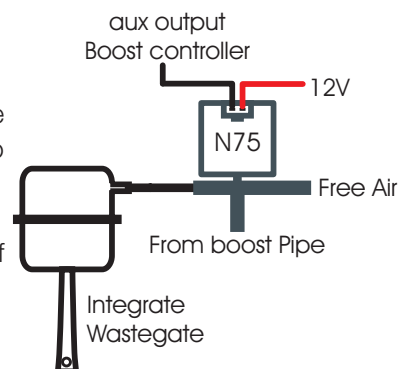

### 13.9 BoostController

The BoostController is used for more precise control of the turbo pressure in street cars, circuit and drag races. The control can be performed by time after 2-step, RPM and gear, gear and time after change, unique value and engine RPM, as well as the control with specific targets for drag race (2-step, 3-step and burnout).

See more information in chapter 19.15 BoostController diagrams.



## 14. Electronic throttle control

### 14.1 Electronic throttle control

Electrical installation of an electronic throttle on FT600 is pretty simple. Check the example diagram below:

#### Connectors rear view

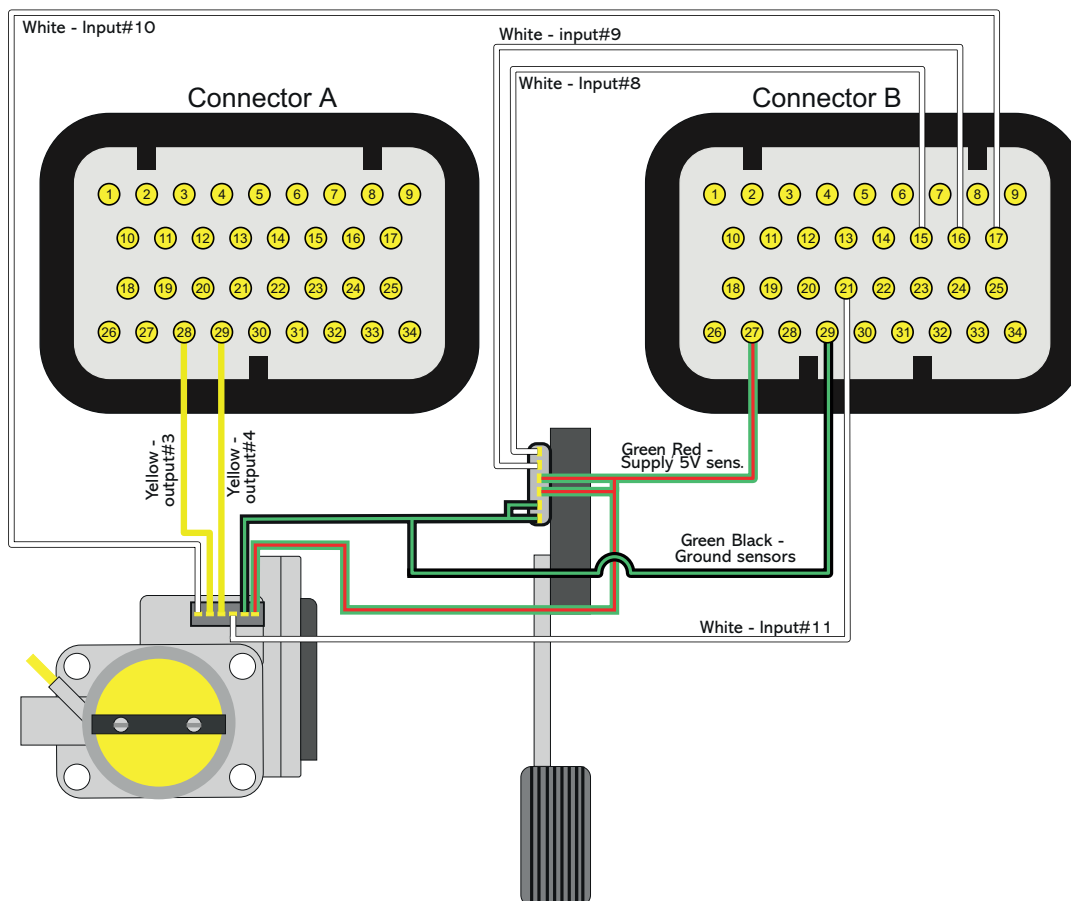

- The yellow wire #3 (pin 28 of connector A) must be connected to one of the pins of the electronic throttle motor.
- The yellow wire #4 (pin 29 of connector A) must be connected to the other pin of the electronic throttle motor.
- The green/red wire (pin 27 of connector B) of the FT700 is a 5V output and must be used to power the pedal and throttle position sensors. It must be divided and connected to both.
  - The green/black wire (pin 29 of connector B) must be connected to the negative for sensors, it can also be shared between the electronic throttle and pedal position sensors.
  - The numbered white wires correspond to the sensor inputs, connected to the pedal position sensors (Pedal 1 and Pedal 2) and throttle (Throttle 1A and Throttle 1B). After connecting and configuring the inputs, it is necessary to calibrate the electronic throttle according to chapter “15.2 Calibration of the electronic pedal/throttle” of this manual.
  - Pins 26 and 27 of connector A (yellow outputs), which will not be used in this case, can be configured as injection outputs or auxiliary outputs.

### 14.2 Connection - throttle bodies and pedals

Check the throttle and pedal wiring before disconnect it from the OEM VCU. If you need, contact our tech support to get more information about throttles and pedals.

With the electrical connections ready, go back to chapter 7.5 and insert the throttle code (FT) that you found on the throttle table connection

If your throttle is not listed in our table, it might be necessary to send it to our tech team to have them check compatibility and research its control parameters. In this case please contact our tech support.

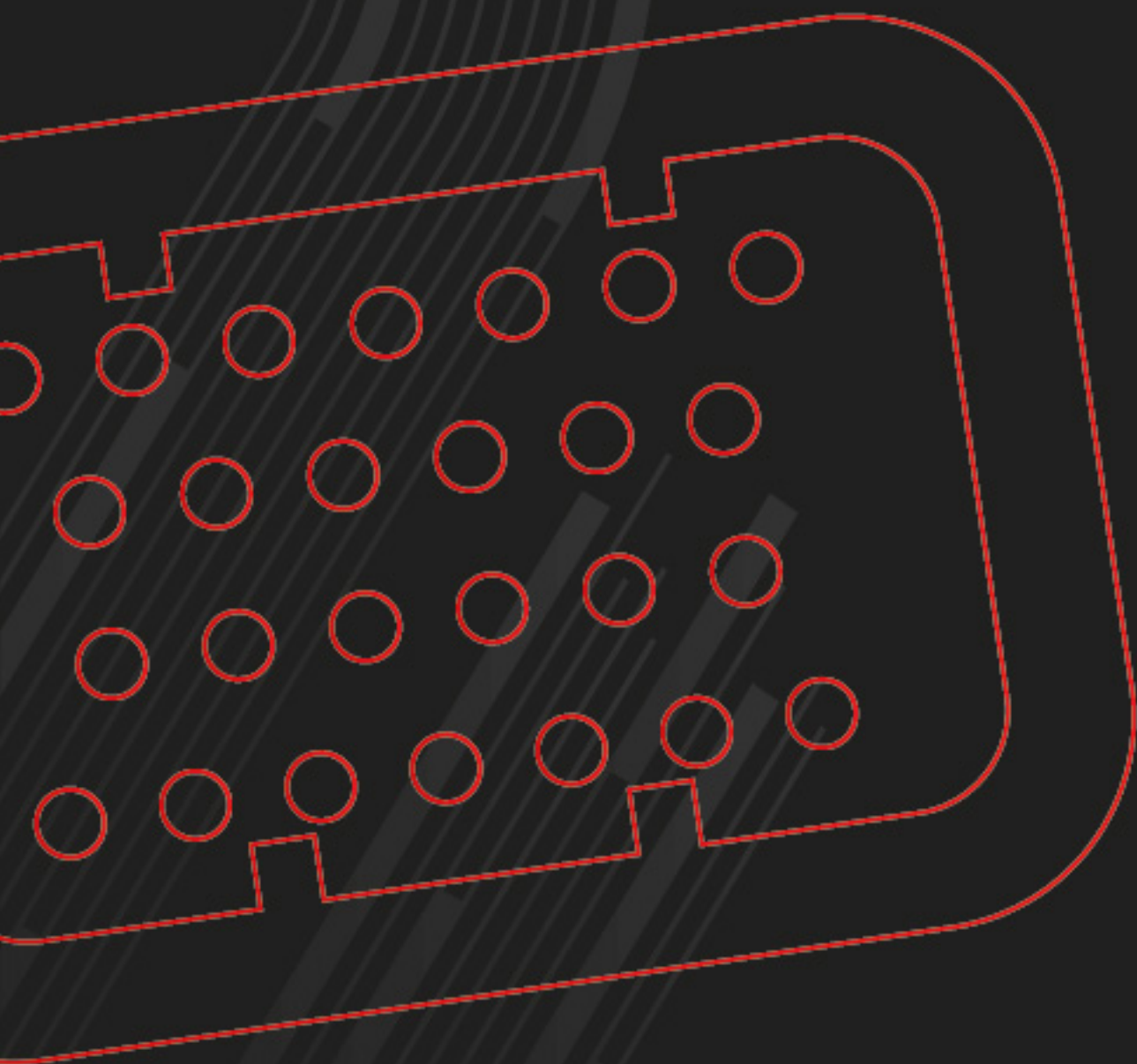

# ***CALIBRATION***

Inputs and Outputs

## 15. Inputs/outputs and calibrations

This section describes an input, an output is and how to configure them correctly, as well as TPS / Electronic Throttle and ignition timing calibration procedures.

These procedures are essential for the VCU to operate correctly on the vehicle.

### 15.1 TPS calibration

Go to “Sensors and calibrations” and then “Calibrate throttle/pedal”.

1. With the pedal on idle position, click button “calibrate” beside the field “Idle: 0%”
2. Push throttle to the maximum and click “calibrate” button beside the field “WOT: 100%”.
3. Press “Save”. Message “Calibration done!” is shown if the process is OK.
4. In case an error message is shown, check TPS connections..

#### IMPORTANT

*To perform this calibration, it is very important that the engine is not running, because the throttle is fully opened and closed*

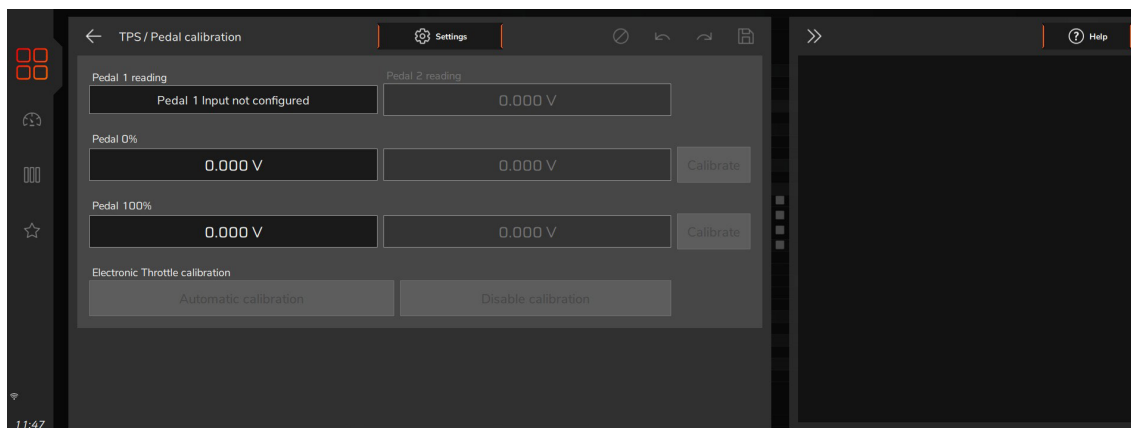

### TPS calibration errors may be:

**Inverted and calibrated:** means the TPS is connected the wrong way, but is working normally. Double check connections, but, know that it will work normally connected this way.

**Possibly disconnected:** check TPS connections. Maybe there is a broken wire or one of the connectors does not reach the TPS pins.

Check with a tester to see if the voltage on the orange wire varies according to the throttle position.

TPS sensor must be calibrated on the first time the ECU is turned on only, and should be recalibrate only when it has to be replaced or the throttle opening on idle was changed. TPS calibrations are individual by map file.

TPS signal voltage must go up, as the pedal is pressed, and must have at least a 3V difference between the idle and WOT positions

### TPS errors and diagnostics

Error message	Diagnostic
TPS range must be higher than 1.5 Volts	The TPS value from 0% to 100% has a smaller difference than 1,5V
TPS signal may be shorted to ground	Ground short circuit for TPS input
TPS signal may be disconnected	TPS input disconnected or short circuited to 5V
TPS calibration is required only when activated	No input configured as TPS.

## 15.2 Electronic throttle/pedal calibration

This calibration procedure is exactly the same as the mechanical throttle calibration. The only difference is that the calibration screen shows voltage value on both TPS's of the electronic pedal.

With this done, it is necessary to adjust idle speed control parameters as guides chapter 20.2

### IMPORTANT

*Every time the pedal calibration is done the throttle automatically calibrates its opening limits. It is very important that during this calibration the engine is turned off because the throttle is fully opened and closed.*

### Throttle body error and diagnostic messages

Error Message	Diagnostic
Throttle #1 channels not found	There is no input configured as throttle input
ETC motor #1 signals may be disconnected	ECU Failed to actuate the throttle motor
Throttle #1A signal may be shorted to ground	Throttle Input A short circuited to GND
Throttle #1A signal may be disconnected	Throttle input A disconnected or short circuited to 5V
Throttle #1B signal may be shorted to ground	Throttle Input A short circuited to GND
Throttle #1B signal may be disconnected	Throttle input A disconnected or short circuited to 5V
ETC 1 code error	Throttle code error

### Electronic Throttle security behaviors

#### Correlation error between throttle and pedal signals

- Happens when the difference between pedal and throttle is higher than 20% for more than 200ms
- The electronic throttle is turned off and returns 500ms after the difference between the signals is below 20%.

#### ETC position tracking error

- Happens when the difference between the desired position and the throttle position is higher than 10% for more than 1 second
- The electronic throttle control is turned off and only returns 0,5s after the difference between the desired position and the throttle position is lower than 10%

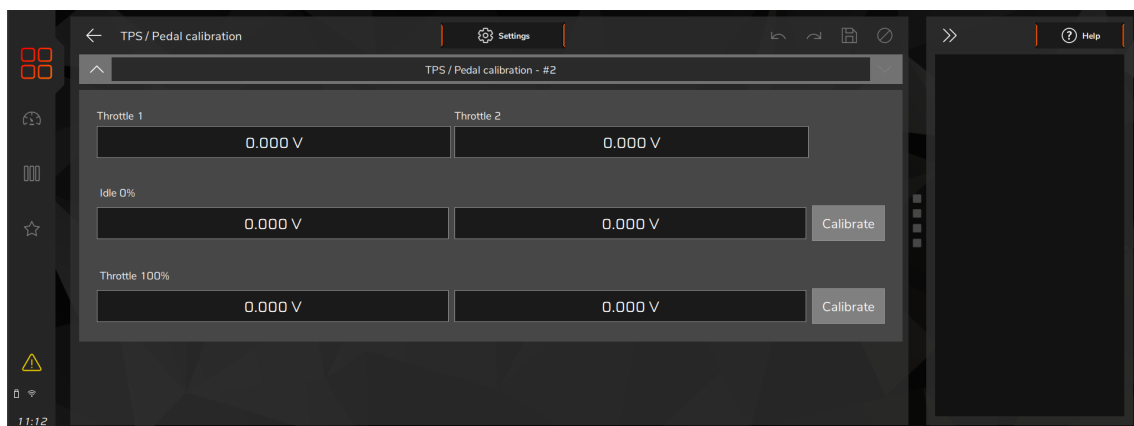

### 15.3 Ignition calibration

As it is not possible to turn the crank trigger as we do on distributor systems, the ignition calibration screen has a compensation that must be changed until the timing light shows 20° BTDC (or 40°, according to the timing light). Let's say you read a timing of 24° BTDC, a compensation of -4° is needed to read 20° BTDC on the crankshaft TDC mark. When the timing light is reading double the real timing (wasted spark), if the timing on the timing light is 46°, the compensation that must be set is -3°, instead of -6°.

This function locks the timing to 20° (or 0°) on any RPM, this means, if the engine starts but has no idle, you can rev it up and keep it in something around 2000rpm to perform the calibration. Avoid RPM variations as this causes variations on the timing light readings.

The rotation can be at any value, as long as it is maintained with the minimum possible variation, as this can cause errors in the gun reading.

Calibration can be performed through the VCU screen or through the desktop software, both have the same parameters used in previous modules of the PowerFT line, the difference is that these parameters are located on the same screen.

Another change is that, after modifying the tooth alignment or correction, this change will also be registered in the alignment menu present in the "Engine Settings" menu.

In cases of distributors, it is also possible to carry out this calibration, instead of turning the distributor, to find the point fixed at 0° or 20°.

#### Procedure for using the timing light

1. Connect the timing light to the battery.
2. Connect the clamp to cylinder cable 1.
3. Separate spark plug wires for reading.
4. Start the engine.
5. Lock the FT in the calibration screen.
6. Keep rotation stable.
7. Look for the TDC mark on cylinder 1.

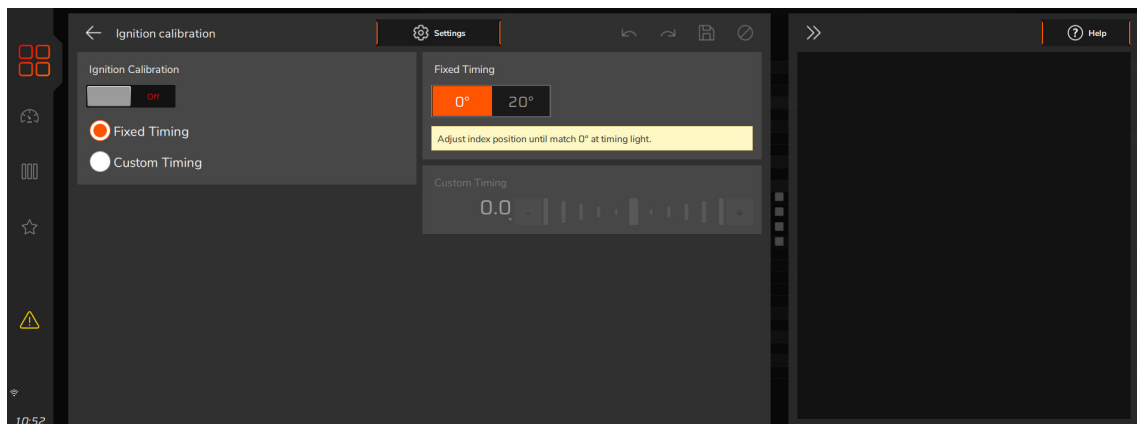

## 15.4 Calibrating eGate #1 and #2 Position

After defining the eGate position control input, calibration is required. This procedure adjusts the valve's opening and closing limits.

There are two ways to perform this calibration: Manual or Automatic.

**Manual Calibration:** Follows the same procedure as the TPS calibration.

**Automatic Calibration:** In FTManager, access the "sensors and calibration/Inputs" menu. Configure the input connected to the wastegate.

**Signal Mode:** For the TurboSmart eGate, select the "Voltage falls when valve opens (default)" option.

**eGate Temperature:** This sensor reads the valve temperature through the wastegate's internal sensor. To use this sensor, connect the eGate's orange or yellow wire to a white input.

If there is any error between the FT reading and the actual value (compared to a pressure gauge), it can be easily corrected by adjusting the sensor offset. The adjustment can be made in volts or in pressure units. Simply toggle the button at the top of the screen between "Input Value" (set in Volts) and "Output Value" (set in pressure units). The "Current Reading" field displays the real-time pressure reading.

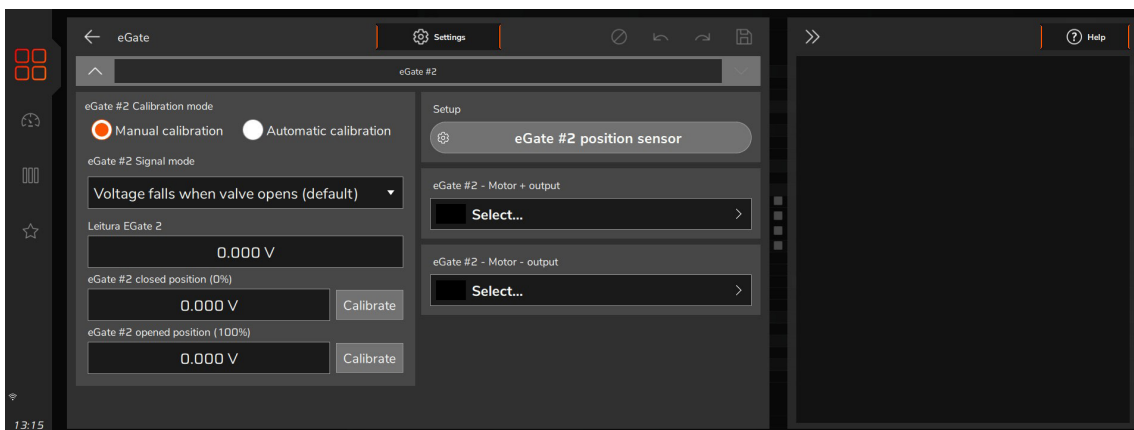
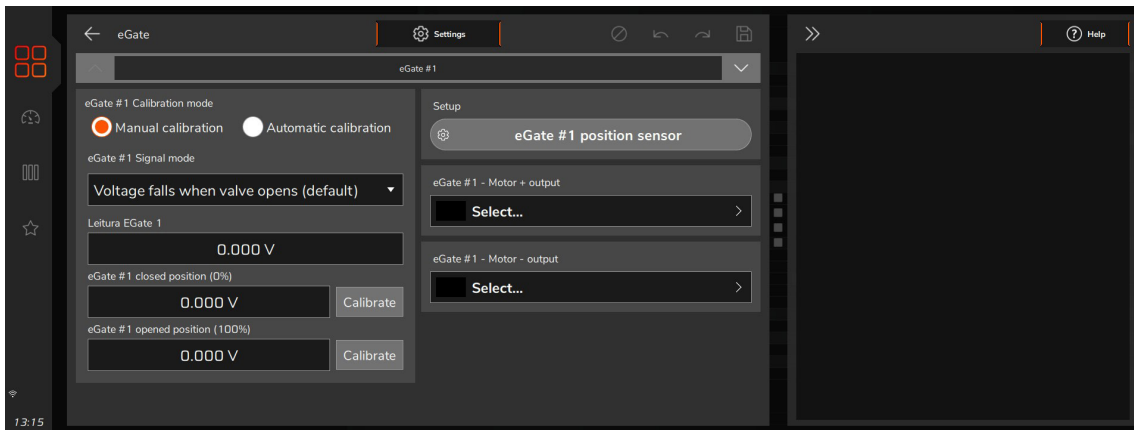

## 15.5 Fuel/oil pressure sensors inputs

In this menu are the settings for fuel and pressure sensors. There is a predefined configuration for PS-150/300/1500 pressure sensors, but any kind of analog sensor with 0-5V signal can be used. This configuration is done through the VCU and software VisionFT.

In case there is a reading error between the FT screen and the real value of the sensor (comparing to an external gauge), this compensation is easily done by adjusting the sensor offset. It is possible to edit this compensation in mV or in pressure offset. Just change the button on the top part of the screen between “*Input value*” (mV adjust) and “*Output value*” (pressure offset). The field “*Read value*” shows readings in real time.

Make sure your external gauge is correctly calibrated and that the correct sensor is selected, as incorrect use of this function can cause significant error in pressures reported.

The FT has fully customizable inputs, which allows to read any 0-5V analog pressure sensor, since its pressure vs voltage table is known. In this case, just select the custom option and fill the interpolation table through VisionFT.

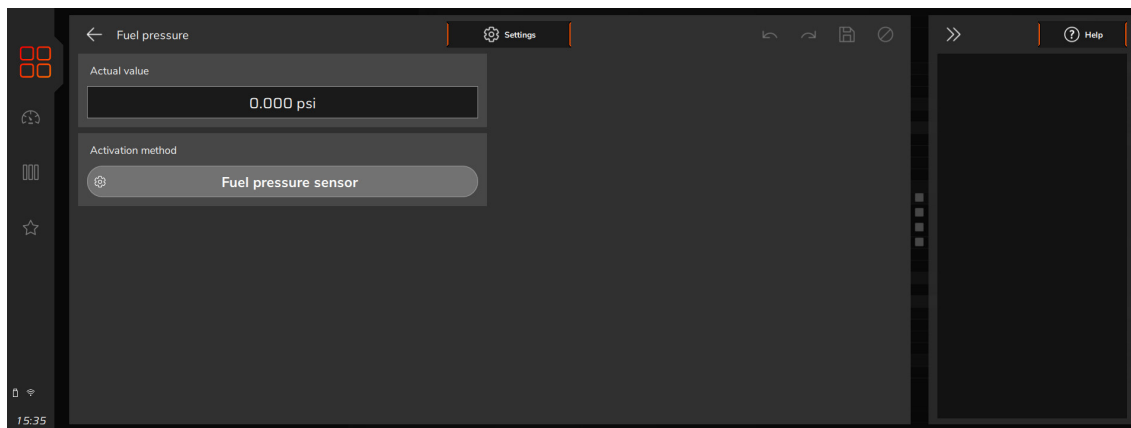
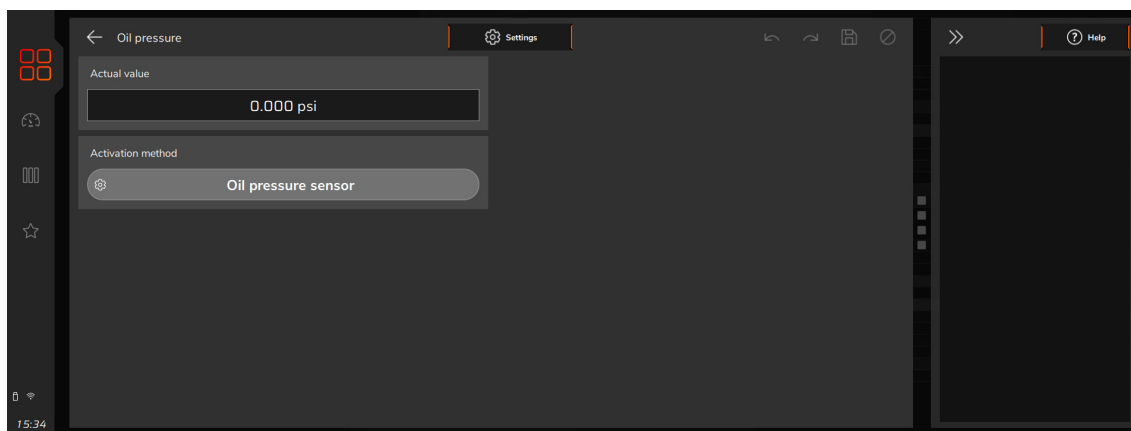

## 15.6 Intake air and engine temperature sensors

In this menu are the settings for intake air and engine temperature sensors. There is a predefined configuration for GM and Fiat sensors.

In case there is a reading error between the FT and the real value of the sensor (comparing to an external gauge or to the dashboard), this compensation is easily done by adjusting the sensor offset. It is possible to edit this compensation in mV or in degrees. Just change the button on the top part of the screen between “*Input value*” (mV adjust) and “*Output value*” (temperature offset). The field “*Read value*” shows readings in real time.

Make sure your external gauge or dashboard is correctly calibrated and that the correct sensor is selected, as incorrect use of this option can cause significant error in reported temperatures and possible engine damage.

The FT has fully customizable inputs, which allows to read any 0-5V analog temperature sensor, since its temperature vs voltage table is known. In this case, just select the custom option and fill the interpolation table through VisionFT.

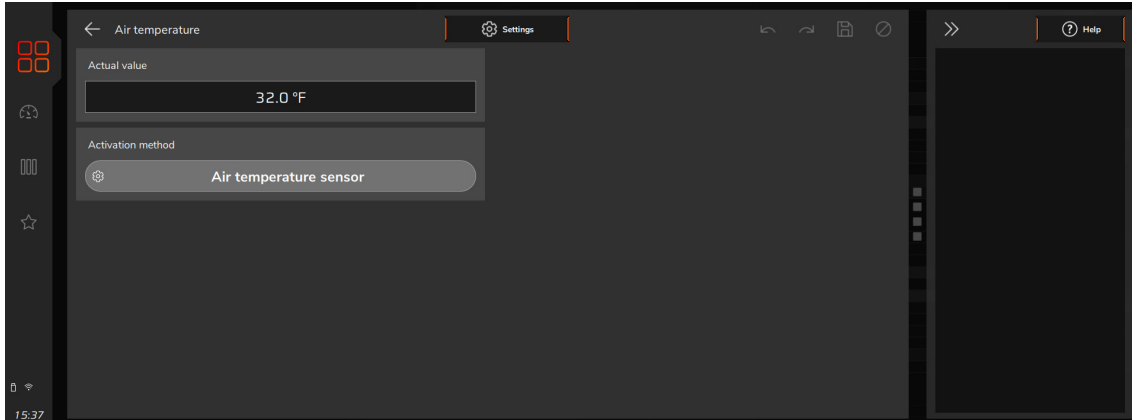
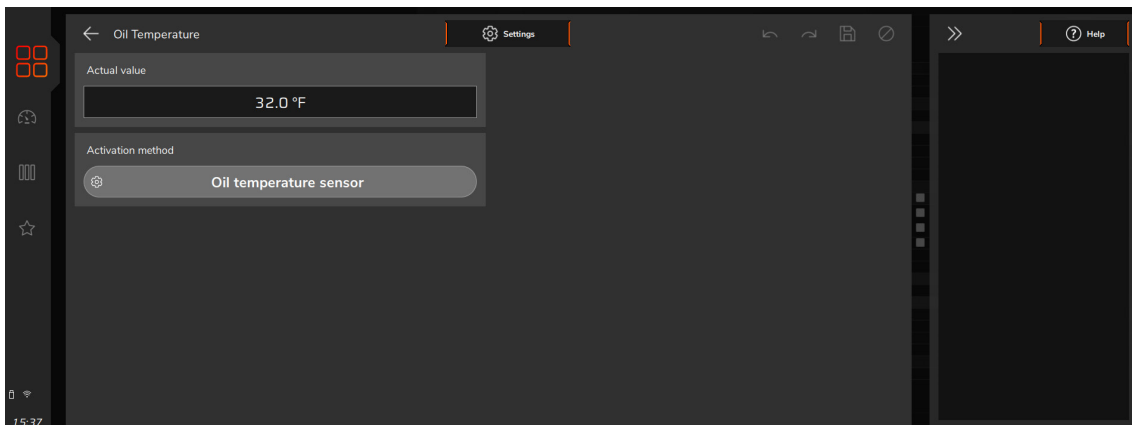

## 15.7 O2 sensor inputs

O2 sensor signal input can be setup on any sensors input of this FT it is even possible to read fifteen O2 sensors simultaneously and show them on the screen. For wide band O2 sensors, it is necessary to use a wide band conditioner, for narrow band O2 sensors, direct connection is allowed.

Be sure to connect the O2 conditioner to FT according to the Chapter 12.7 of this manual.

### CAN network reading

Through CAN network the reading is sent directly to FT, the only configuration necessary is to indicate what is the position of each sensor, this procedure is called "Association".

The association procedure is executed by disconnecting from the conditioner a single sensor at time, this way the FT identifies and associates that sensor to the position of the engine (cylinder 1, general O2 sensor).

Follow the steps and repeat for each O2 sensor:

1. Keep the conditioner connected and turned on and disconnect the O2 sensor;
2. Press the Associate button on FT or on the "CAN communication of VisionFT" window;
3. Reconnect the O2 sensor and repeat the process for all other O2 sensors;

### Analog input reading

The O2 sensor reading through an analog input is used either to narrow band or wide band with conditioners that have analog output (FuelTech WB-O2 Slim WB-O2 Nano WB-O2 Datalogger and Alcohol O2), Simply set the sensor in any input of FT (white wires).

It's necessary to set the input scale according to the analog output of conditioner used. If it's a FuelTech conditioner select one of the preset scales. For other manufacturers use the custom table. The narrow band sensor reading is displayed directly in Volts.

Analog scales compatible with the FT are:

Scale	Output voltage
0,35 - 1,20	0,35 = 0,2V - 1,20 = 4,8V
0,59 - 1,10	0,59 = 0,2V - 1,10 = 4,8V
0,65 - 1,30	0,65 = 0,2V - 1,30 = 4,8V
0,65 - 4,00	0,65 = 0,2V - 4,00 = 4,8V
0,65 - 9,99	0,65 = 0,2V - 9,99 = 4,8V

### WB-O2 Nano, Slim or Datalogger calibration

Offset calibration is needed to compensate analog signal loss. With O2 sensor connected and configured go to "Calibrate O2 sensor" (through display) or click in "Calibrate sensor" in VisionFT software.

To calibrate O2 sensor, proceed as follows:

1. Check the scale of FT with external conditioner, they must be equal.
2. With the engine running, stabilize the O2 reading.
3. Adjust the offset until the reading in the conditioner matches the reading in the VCU.
4. If the calibration and configuration are correct, there will be no reading difference.

## NOTES

*If the difference is greater than 0.02 between the readings, it means that the scales are different.*

## 15.8 Wheel speed

This function allows you to configure the front and rear wheel speeds through sensors connected directly to the vehicle's wheels.

**Number of teeth:** Configures the number of teeth that the sensor will read until it completes a turn. The higher this number is, the faster and more accurate the speed detection is.

**Tire type:** Lastly are the tire size settings.

**Slick/DragRace:** It is only necessary to inform the tire diameter (in inches). See the first image where the front tire size is 34" and the rear tire size is 24.5"

**Radial:** In addition to the wheel rim, the width of the tire and its profile must be configured. See the second image for the front tire, the size 315/60 R15 was configured and for the rear 205/65 R15.

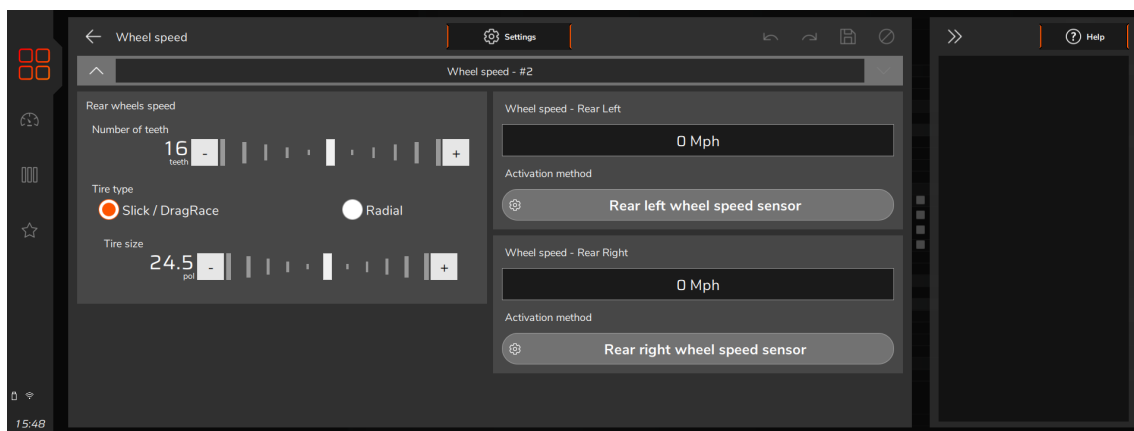
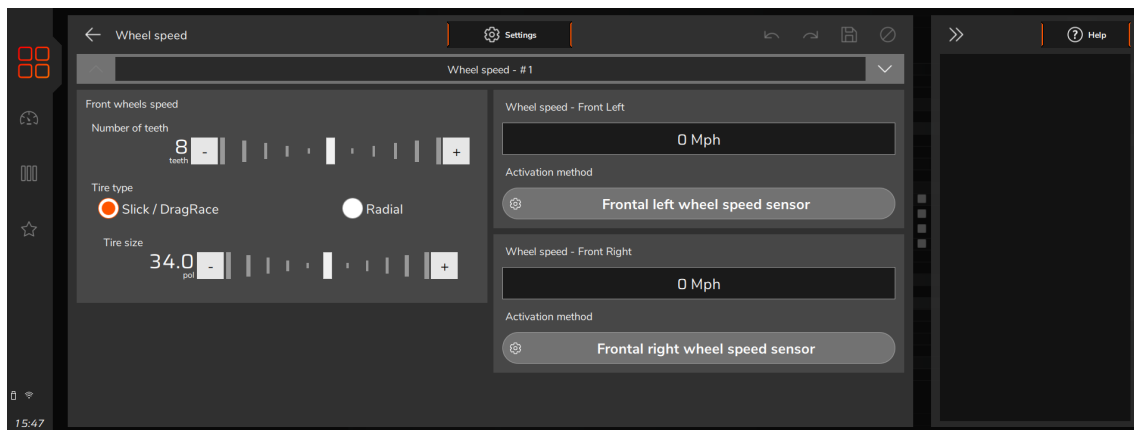

### 15.9 Drive shaft RPM

With the driveshaft RPM and the tire size, it's possible to calculate the traction wheel speed. If you want to use the driveshaft RPM sensor to get wheel speed instead of using a wheel speed sensor, just check the "Calculate wheel speed" check box.

**Number of teeth:** Insert the number of teeth read per revolution.

**Calculate wheel speed:** If you want to use the Drive shaft speed instead of a wheel speed sensor, enable this option. To do so, enter the ratio of the differential used. In this case, it is necessary to have a speed sensor installed on the Drive shaft.

**Tire type:** Insert the tire size settings.

For Slick/Drag Race tires it is only necessary to inform the tire diameter (in inches).

For radial type tires, it is necessary to configure, in addition to the wheel rim, the width of the tire and its profile. In the example on the screens, there are the settings for a tire with a 15-inch rim, 315mm wide and a 60 profile (315/60 R15).

**Signal Filter:** Select the type of filter for reading

**Legacy high average points:** Smoother signal but may be delayed, default filtering method on 4.11 update and older.

**Noise rejection filtering:** Quicker response, more detailed signal.

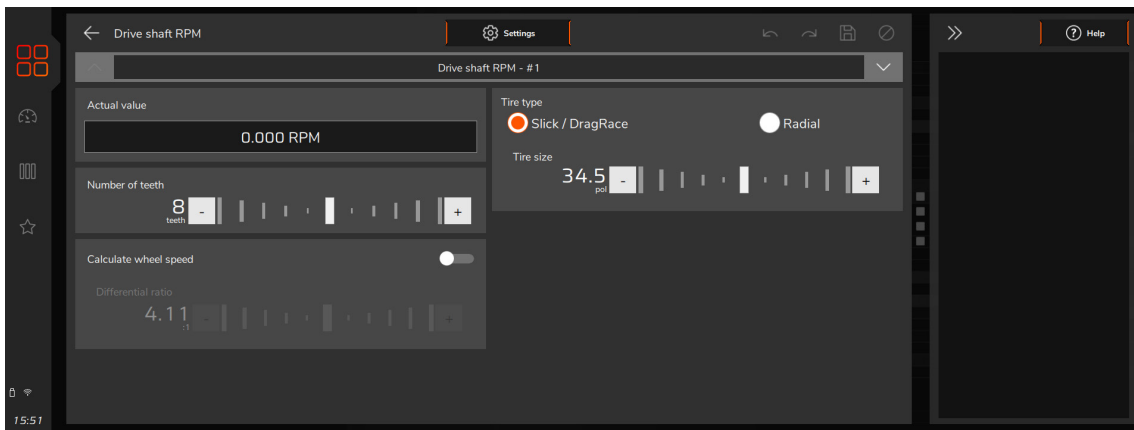

### 15.10 Input shaft RPM

This option lets you read the gearbox input shaft RPM through a white input. It's very useful to analyze the clutch slip during launch.

Setup a white input as "Input shaft" and enter the number of teeth per revolution.

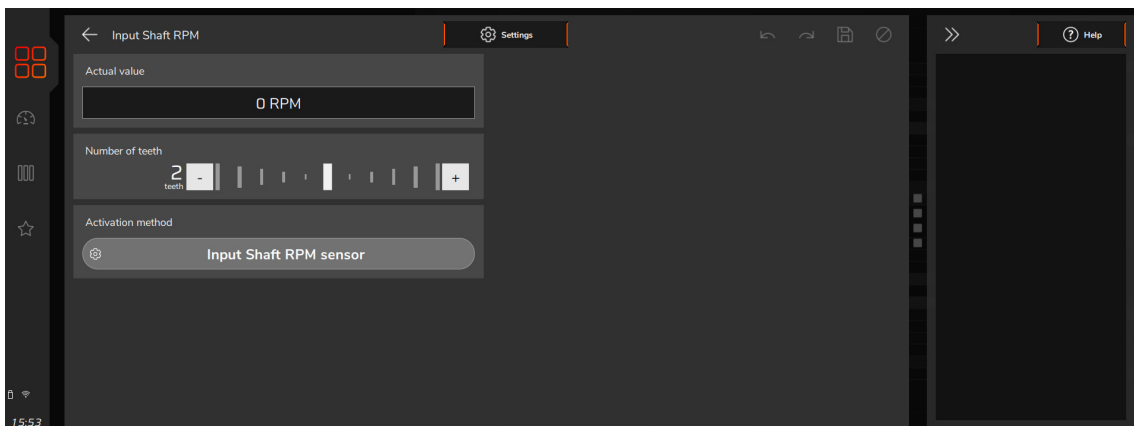

### 15.11 MAP Sensor

This menu allows to setup the internal MAP or an external one.

**Internal MAP:** Can read up to 87PSI and it's average points and Q factor can be changed for smoother readings on engines with high cam profiles.

**External MAP:** Can usually read pressures higher than 87PSI, a white input must be used to setup an external MAP sensor for more than 87PSI.

When using internal MAP is possible to change average points, higher the number, smoother the reading.

Digital filter activated means the VCU will ignore readings over filter frequency set. Q factor is how aggressive the filter acts, higher the number more aggressive it will be, recommended values around 0.60.

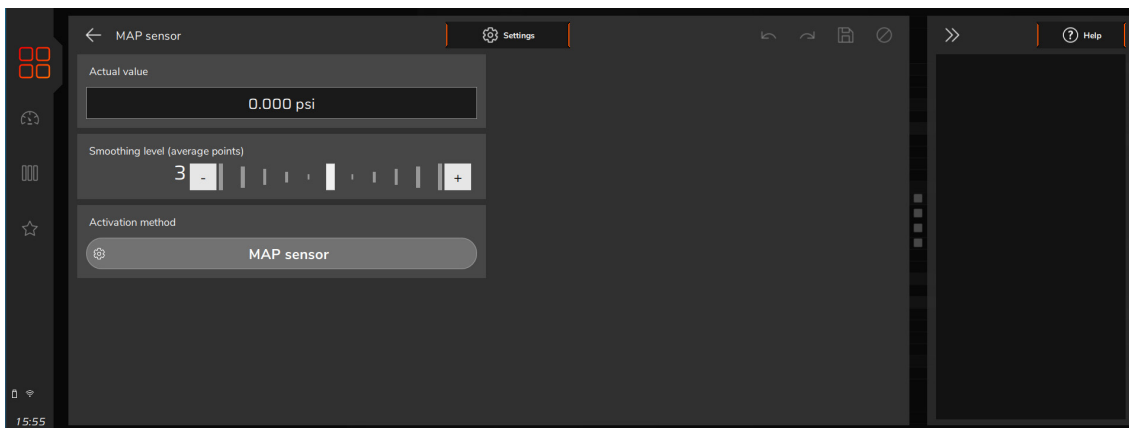

### 15.12 Gear detection

In this menu are the settings for detecting the gear currently engaged for display on the VCU display and on the internal Datalogger.

There are ten ways to make this detection: by RPM drop (for drag race only), by analog gearshift sensor (only for gearshifts already equipped with the sensor), by interpolation of current speed versus engine RPM, and by pulses, by FTCAN 2.0, an output for gear shifting (for cars that have GearController), an integrated GearController or even an automatic transmission control.

To view the engaged gear at the time, go to the dashboard configuration and add the "Gear" gauge in any position.

**Number of gears:** Set the number of gears.

**Differential ratio:** Configures the differential ratio, this value will be used to calculate which gear is engaged.

**Gear detection delay:** It is possible to configure a delay in milliseconds for gear detection.

**Gear reset source:** To inform the status of the 1st gear to the VCU you can press the 2-step button or a dedicated external button.

**2-step:** 2-step button triggered by 0V

**Gear reset input button:** Select the active mode of the button, in 0V or in 12V.

**Gear reset button activation mode:** Select which will be the activation, in 0V or 12V.

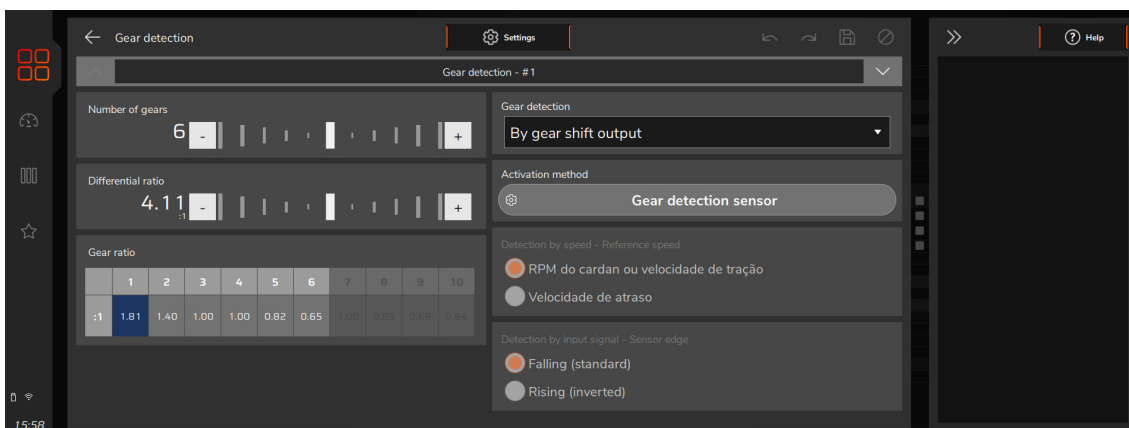

**RPM drop:** This mode uses the RPM drop when up shifting to detect a gear change. Cannot detect downshifts and requires the 2-step to be activated to reset the counter, so it is best suited for drag race cars.

After setting the RPM drop according to each gear, set the minimum “duration” each gear – this feature that helps if there is traction loss, preventing false change detection.

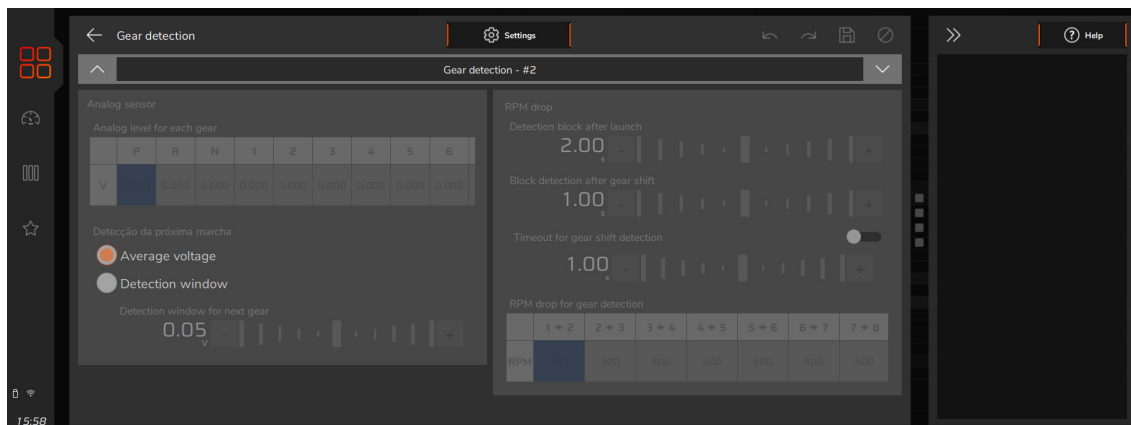

**Analog sensor:** This mode uses an input that reads a potentiometer that indicates the engaged gear in transmissions already equipped with this sensor. Select the input that will read the sensor signal and then configure each gear voltage. To find the gear voltage, use a multimeter connected to the output of the gear position sensor and engage a gear at a time.

**Next gear detection:** To obtain voltage values, engage gear by gear and take measurements with a multimeter on the 20 Volt scale.

**Average voltage:** works with voltages between the defined values of the levels for gear detection.

**Detection window:** Defines a voltage window where detection can occur.

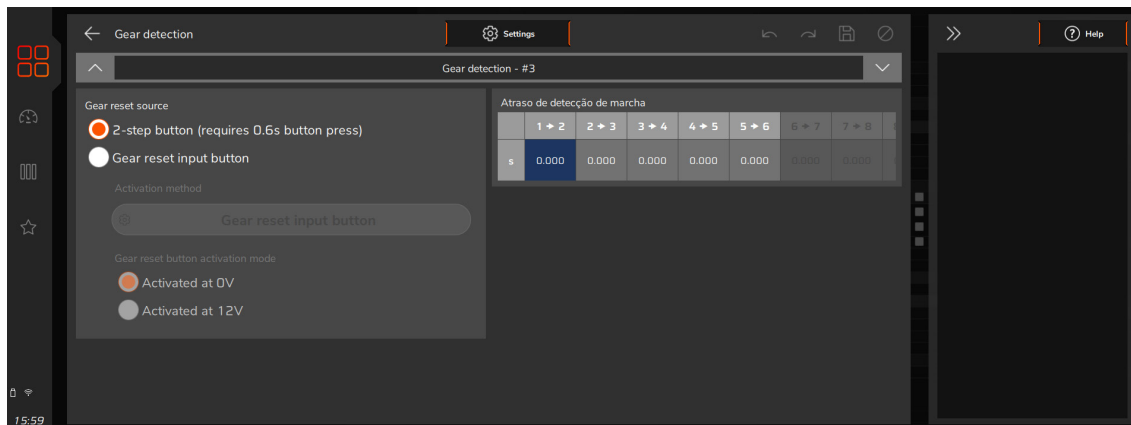

**By input signal:** This mode increments the gear count for each pulse received at a white VCU input. Configure on which of the signal edges the count should be incremented (default: falling edge). Configure an input as “Gear Detection” and turn on the button that will increase gears on it. It cannot detect downshifts and requires 2-step to be activated to reset the count, so it is best suited for drag vehicles.

**By wheel speed or driveshaft:** This mode interpolates wheel speed information with gear ratio information and thus detects the gear currently engaged. Wheel speed reading is mandatory for this mode. Go to Speed Inputs and configure a speed reading mode (white input connected to a wheel speed sensor or speed reading through CAN port – vehicles with GearController and wheel sensors installed).

Basically, it is necessary to configure the vehicle’s differential ratio and the gear ratios that the gear detections start working with the vehicle in motion. When the speed reading is 0, the display reads “N” (neutral).

**By gear shift output:** in this case, at each pulse sent by the gearshift output, the gear detection is automatically incremented. It cannot detect downshifts and requires 2-step to be activated to reset the count, so it is best suited for drag vehicles.

**By gearshift output (Liberty):** This mode must be used when the car is equipped with a Liberty gearbox, where a solenoid will be responsible for gear-shifting.

**FTCAN 2.0 (External GearController):** This mode is for when gear detection comes through an external GearController.

**By integrated Power Shift (GearController):** This option was developed for the FT450, FT550 and FT600 that have the function already integrated into the VCU.

**By automatic transmission control:** This option allows you to detect the gear change through an automatic transmission.

**By Gear control management:** This function allows the control of sequential racing gearboxes, with paddle shift actuation, gear sequence in drum R-N-1-2-3-4-5-6 and solenoid actuation by pneumatic system or electric.

### 15.13 Nitrous bottle pressure

In this menu there are settings to measure the pressure of the nitrous bottle, in this way you can make a compensation Menu “*Drag Race Features*”, “*Pro-Nitrous*” due to the nitrous pressure. To carry out this reading, a PS-100 Sensor or similar must be used.

If there is any reading error between the FT and the real value (compared to a pressure gauge), it can be easily corrected by adjusting the sensor offset. You can adjust in Volts or in Pressure Units. Just change the button at the top of the screen between the options “*Input value*” (adjustment in Volts) and “*Output value*” (adjustment in pressure units). The “*Current Reading*” field shows the real-time pressure reading.

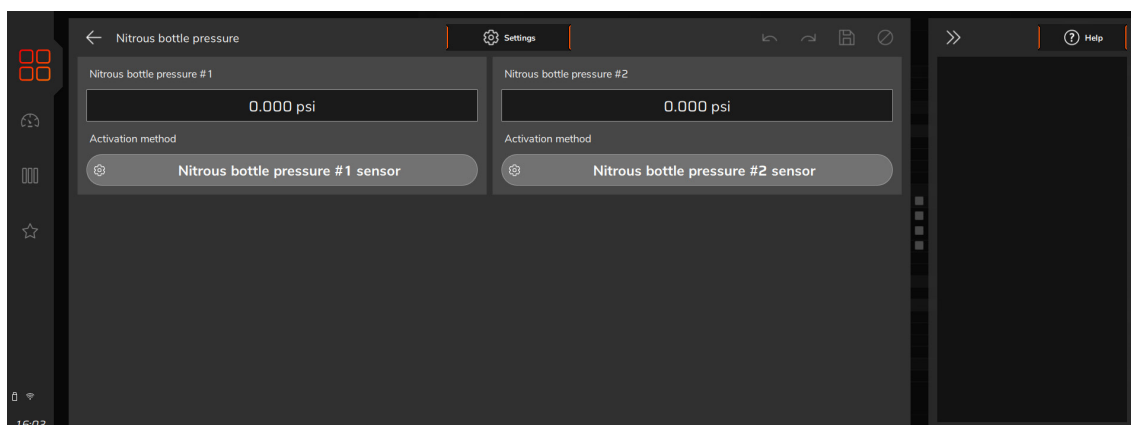

## 15.14 Clutch

**Clutch Position:** In this menu are the settings to read the clutch position. A potentiometer must be used, similar to a TPS. After the wiring done, the calibration is required.

**Clutch Pressure:** This function allows to measure the pressure of the liquid on hydraulic assisted clutches. To read the pressure, use a PS1500 sensor or a similar one.

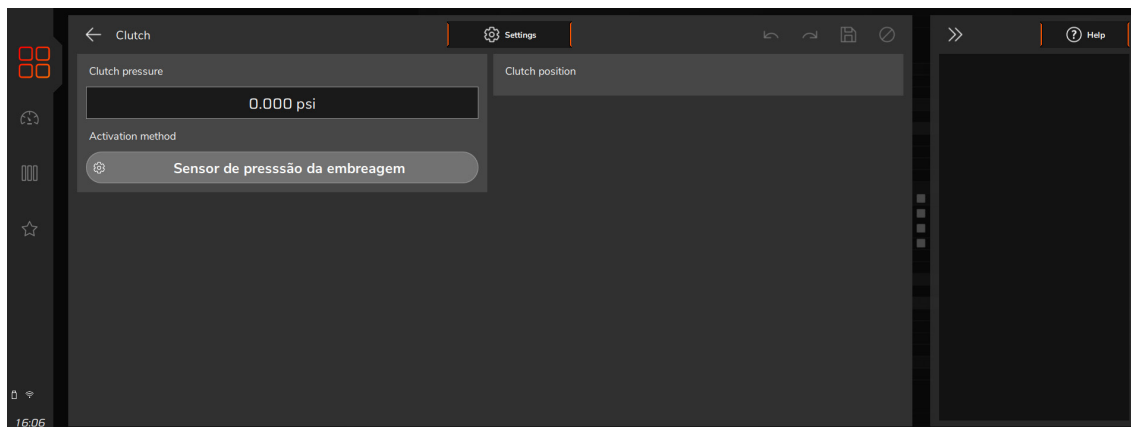

## 15.15 Height

This function allows to read the front end height from the ground. The “wheelie control” is based on this input and you can find more on this at Chapter 21.9. Normally, a laser height sensor is used.

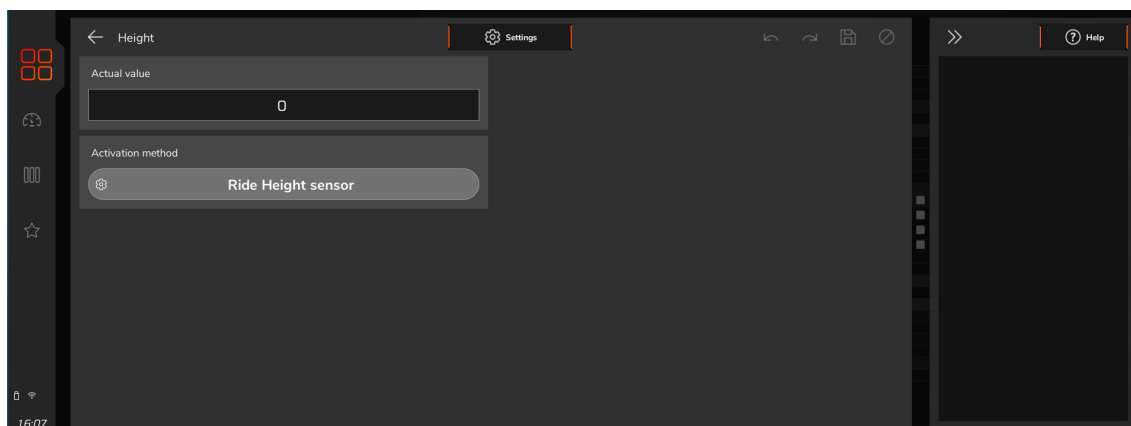

## 15.16 Pitch

This function reads the rate at the front end pitches and is given by degrees per second.

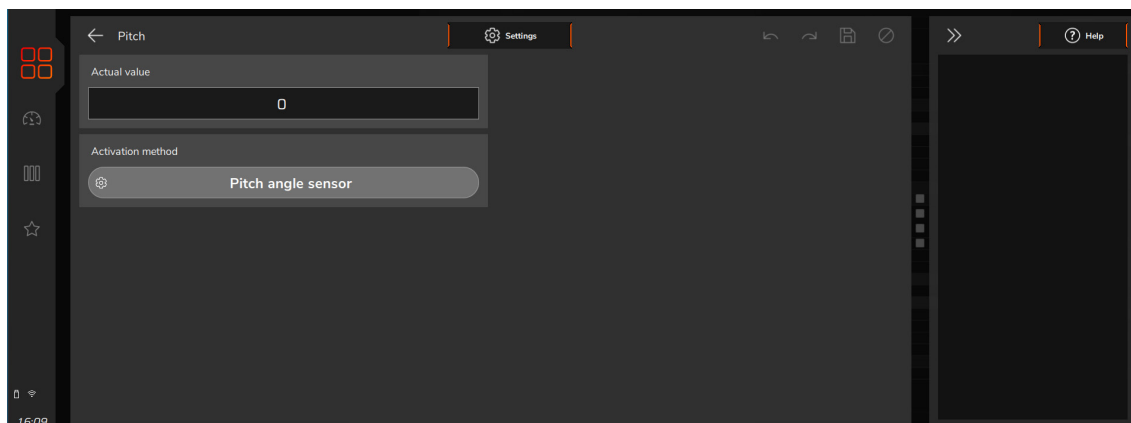

### 15.17 EGT

This menu allows to setup the EGT conditioners (ETM-1 or EGT CAN) and to perform the cylinder attribution. To do it, simply select the cylinder where the EGT is placed and what is the conditioner.

The attribution can be done using the CAN network with EGT CAN or using the white wires inputs with ETM-1.

To use EGT CAN, FTCAN 2.0 must be selected, then which model is being used (EGT A or B - for EGT-8, and the channel) or (EGT A, B, C and D - for EGT-4, and the channel).

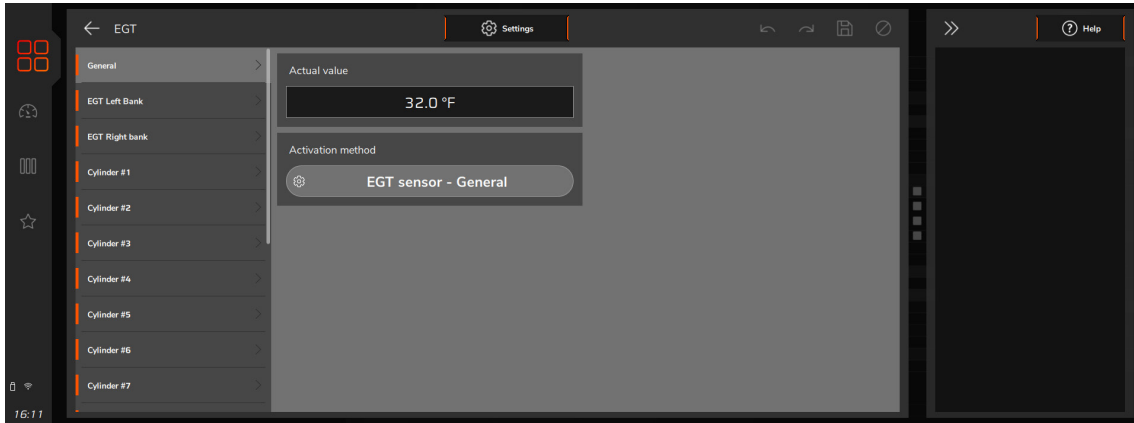

### EGT Settings

To configure EGT, access the menu “Sensors and Calibration / CAN communication/ EGT” an EGT image appears, click on the channels you want to configure and select from the list which will be sensor associated with this channel.

### 15.18 Wastegate Pressure

Configure the sensors for controlling the pressure in the wastegate. For more information, see chapter “20.16 Boost-Controller 1 and 2” for more information.

If there is any reading error between the FT and the real value (compared to a pressure gauge), it can be easily corrected by adjusting the sensor offset. You can adjust in Volts or in Pressure Units. Just change the button at the top of the screen between the options “Input value” (adjustment in Volts) and “Output value” (adjustment in pressure units). The “Current Reading” field shows the real-time pressure reading.

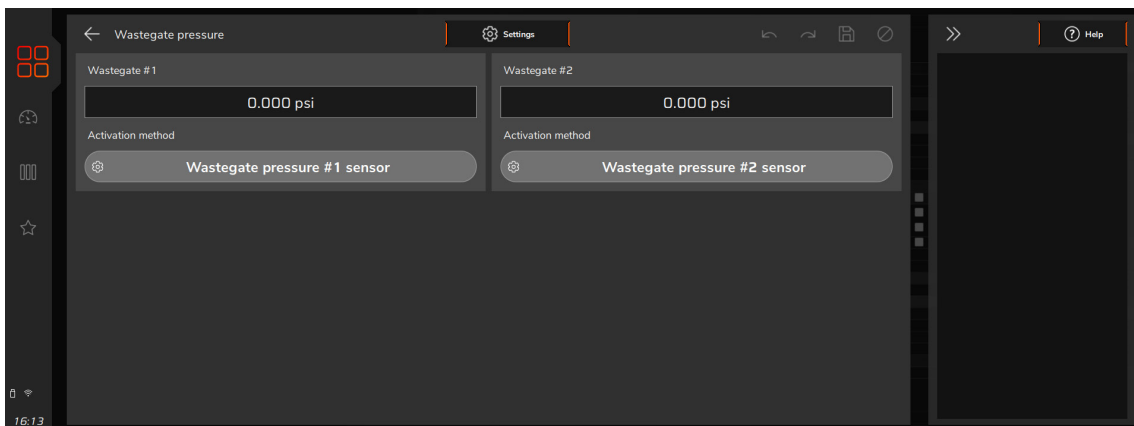

### 15.19 Internal accelerometer

**Accelerometer multiplier factor:** it is typically 1.00, meaning that no multiplier factor will be used and that readings will be the original ones, from the accelerometer. If you notice that the calculated “Accel speed” from accelerometer is not matching a known vehicle speed reading (i.e. time slip showing 220mph on 1/4 mile but your datalogger Accel speed by accelerometer says 200mph) and you have already performed the accelerometer calibration and adjusted the filter frequency, then the multiplier factor must be changed from 1.00 to 1.10 in order to make Accel G readings increase by 10%, consequently increasing the calculated Accel speed also by 10%. This is very helpful when the active traction control is using the Accel speed as Reference speed and traction wheel speed (calculated by the driveshaft rpm) to calculate the wheel slip %, or when you have another external accelerometer device you are used to and want to make both match.

**Calibration:** The first step is to calibrate the accelerometer to compensate a tilted installation of the VCU, it must show 0G when vehicle is stopped and leveled.

**Filter frequency:** The filter is used to remove unwanted vibration so, if you have the VCU mounted on an OEM dash that is very isolated from chassis vibration you can probably use a higher filter frequency (62Hz or 125Hz) so it will improve reading of the small accelerometer changes. If you experience vehicle chassis vibration transferring and affecting the accelerometer readings, then a lower filter frequency (example as 15hz) is recommended.

! IMPORTANT

*A greater filter frequency will result in signal reading delay.*

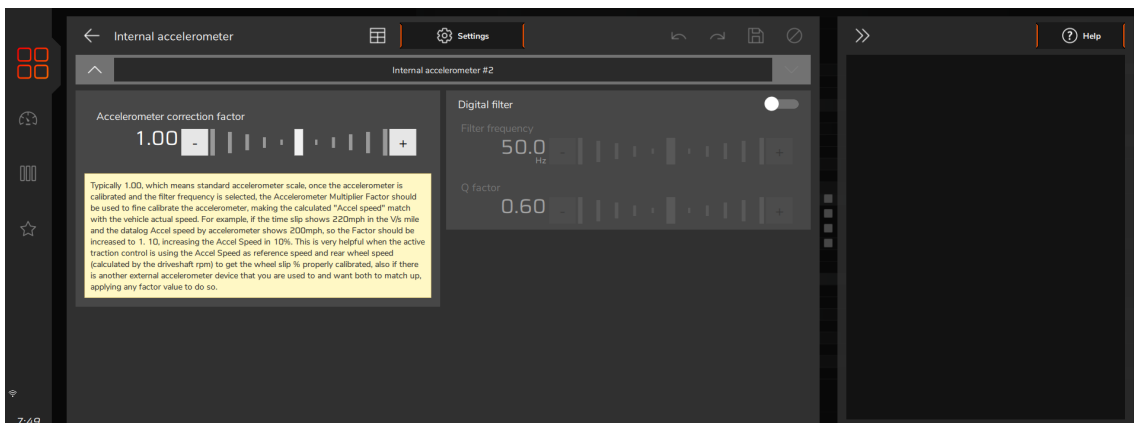
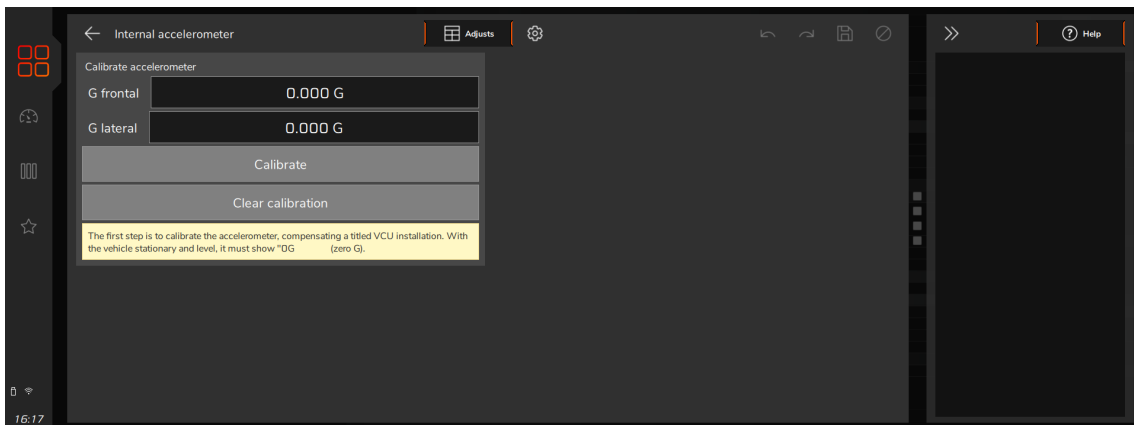

**VCU position:** choose between vertical or horizontal.

**Acceleration direction:** choose between Side of the VCU or perpendicular to the screen.

**Acceleration signal:** choose between normal or inverted.

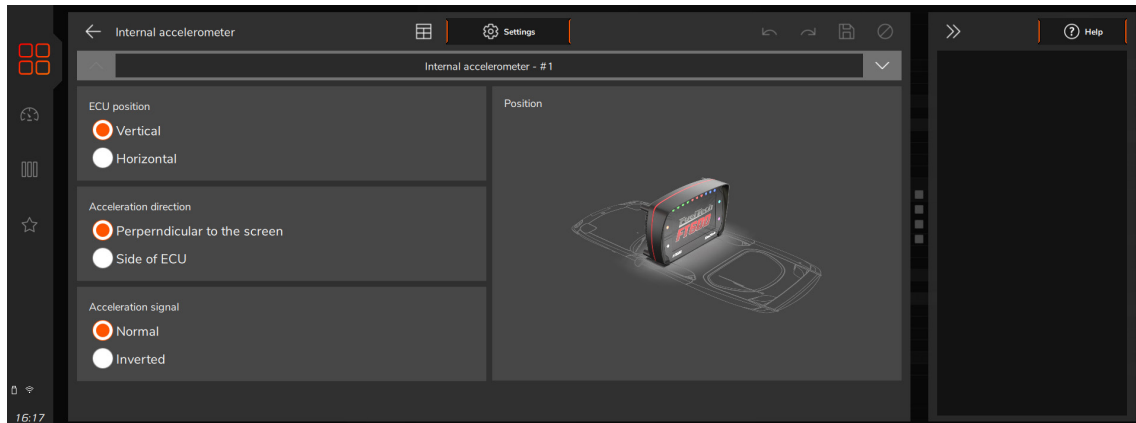

## 15.20 Shocks

Configure the shock absorber stroke sensor for each vehicle wheel, define which stroke will be used by the sensor.

If there is any reading error between the FT and the real value (compared to a pressure gauge), it can be easily corrected by adjusting the sensor offset. You can adjust in Volts or in Pressure Units. Just change the button at the top of the screen between the options “*Input value*” (adjustment in Volts) and “*Output value*” (adjustment in pressure units). The “*Current Reading*” field shows the real-time pressure reading.

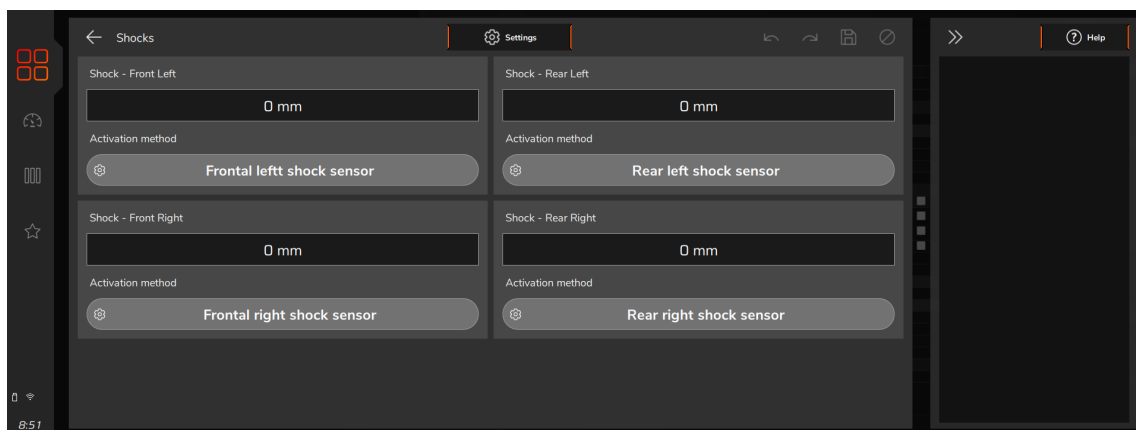

### 15.21 Flex Fuel

This function allows the use of a GM Flex Fuel sensor to measure the ethanol density that the gasoline has on the fuel line.

**Discard reading during engine start:** (where the drop on battery voltage may affect the sensors 12v power supply) and use values read before cranking.

**Discard reading under high load:** (where the high flow of fuel may affect the sensor readings) and use only below 2500rpm.

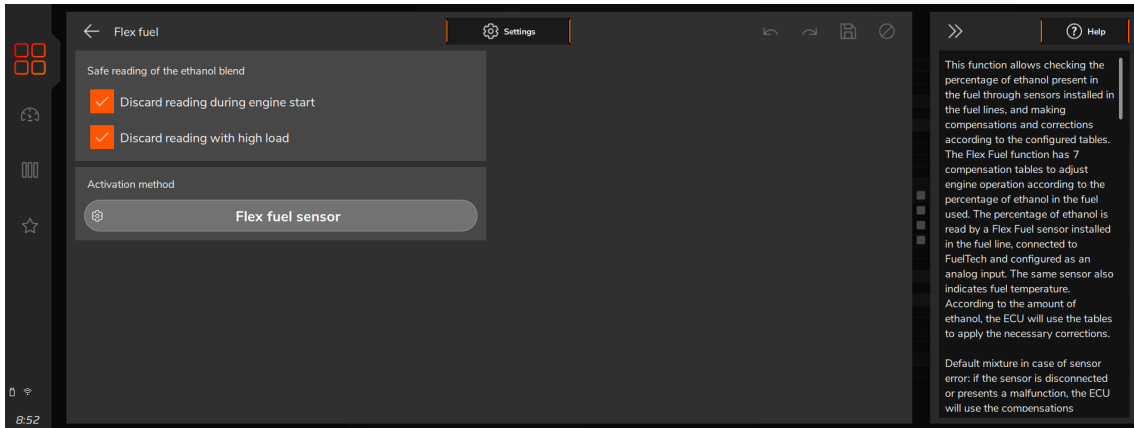

### 15.22 Backpressure

This function allows to set up a pressure sensor to be used on the exhaust to measure back pressure.

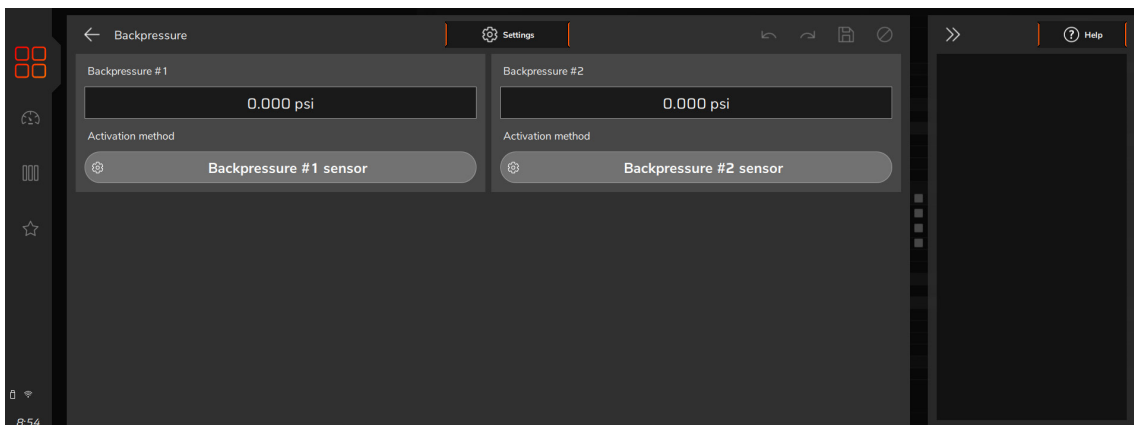

### 15.23 Pan vacuum

Used to measure pressure inside the oil pan.

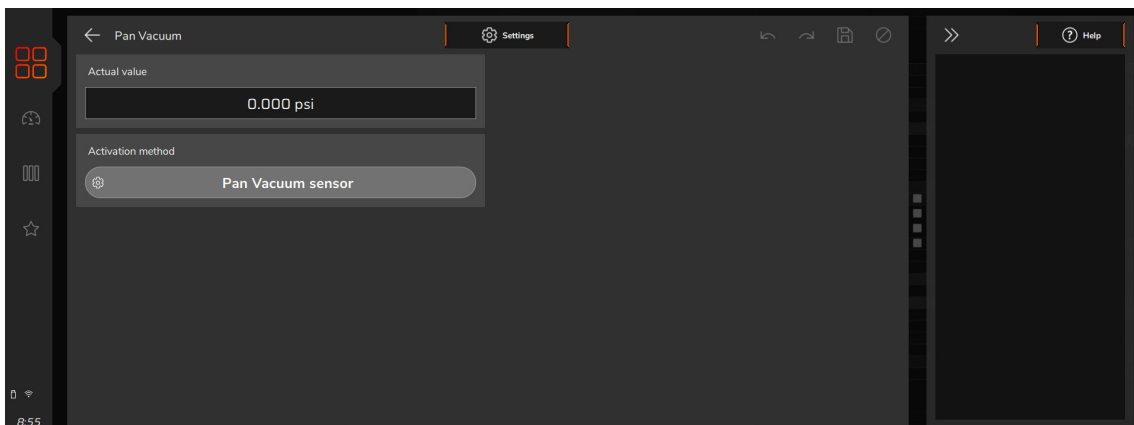

## 15.24 Transmission pressure

Monitors the pressure inside the transmission.

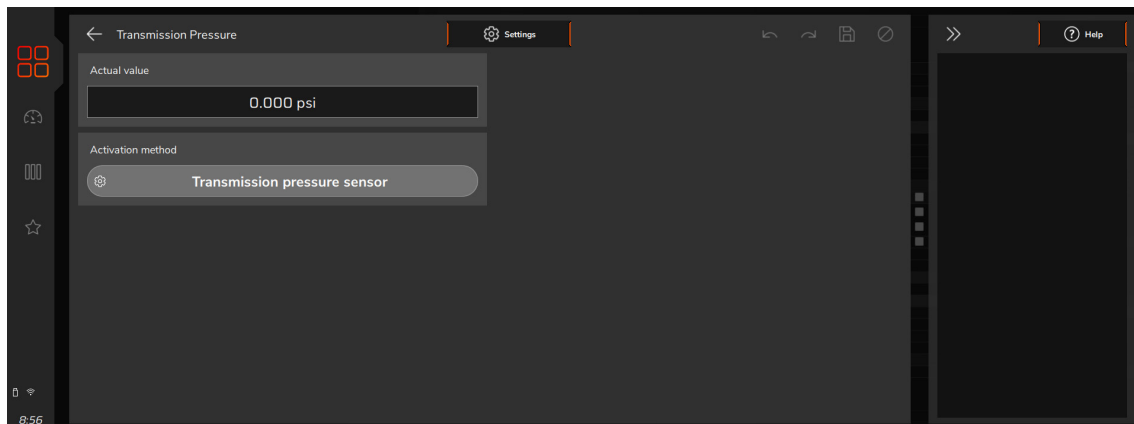

## 15.25 Transmission temperature

Allows to set a sensor to measure the oil temperature

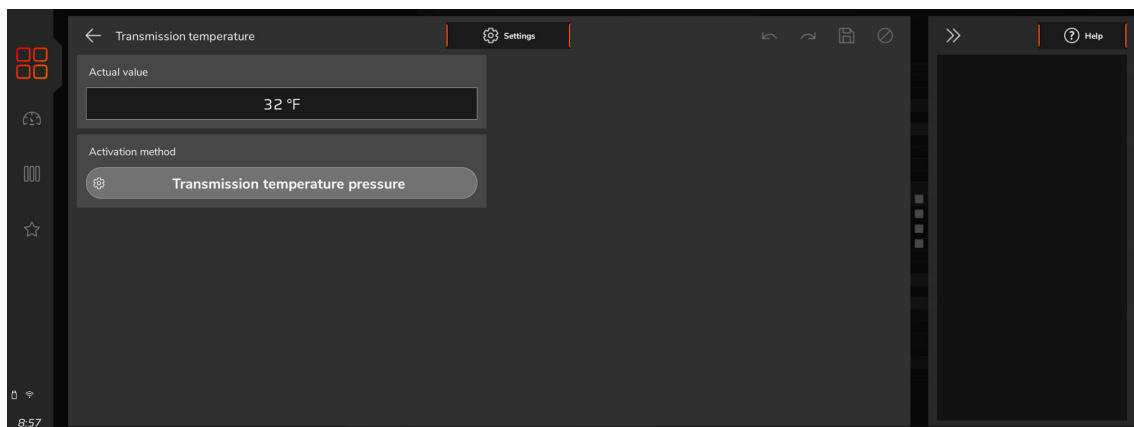

## 15.26 Torque converter pressure

This function allows to set up a pressure sensor to be used to measure torque converter pressure.

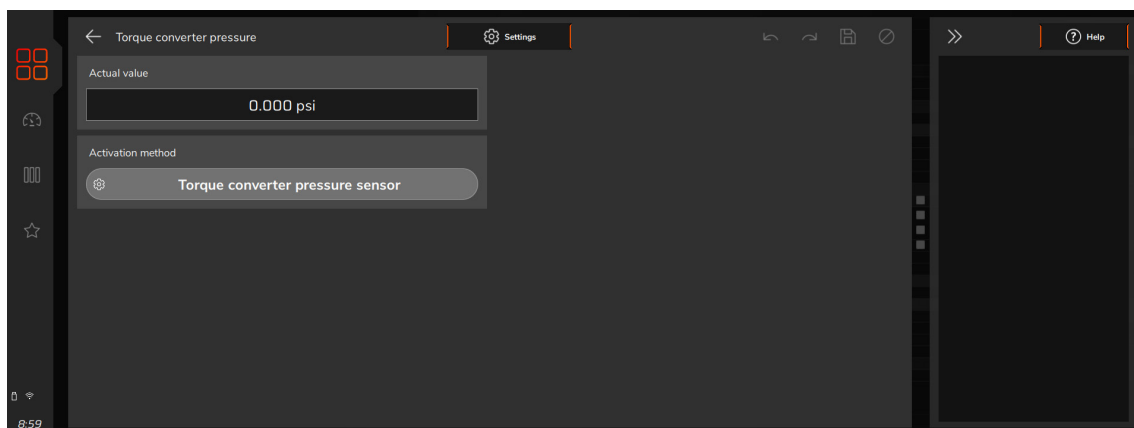

## 15.27 Intercooler temperature

Used to monitor intercooler temperature.

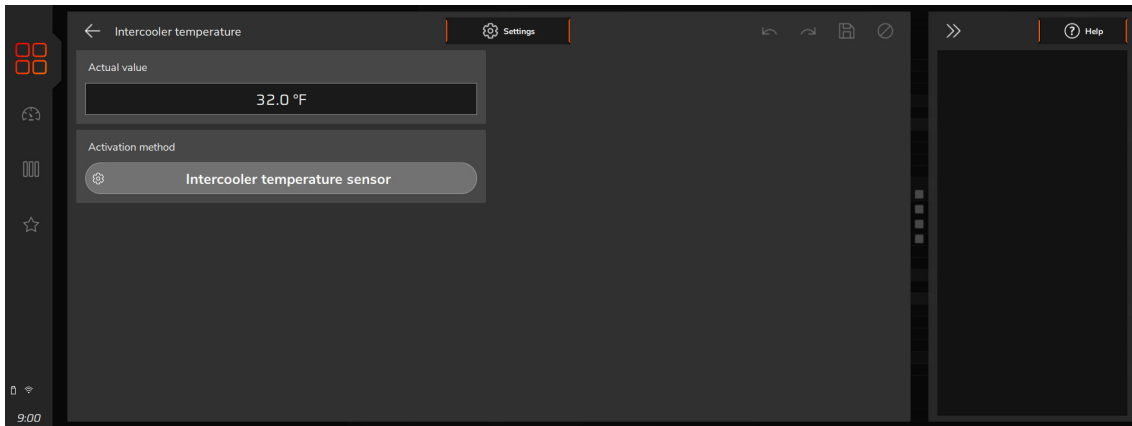

## 15.28 Wheel temperature

Allows to monitor tire temperature using a laser sensor with either an ETM-1 wired into a white input or an EGT-4 via CAN.

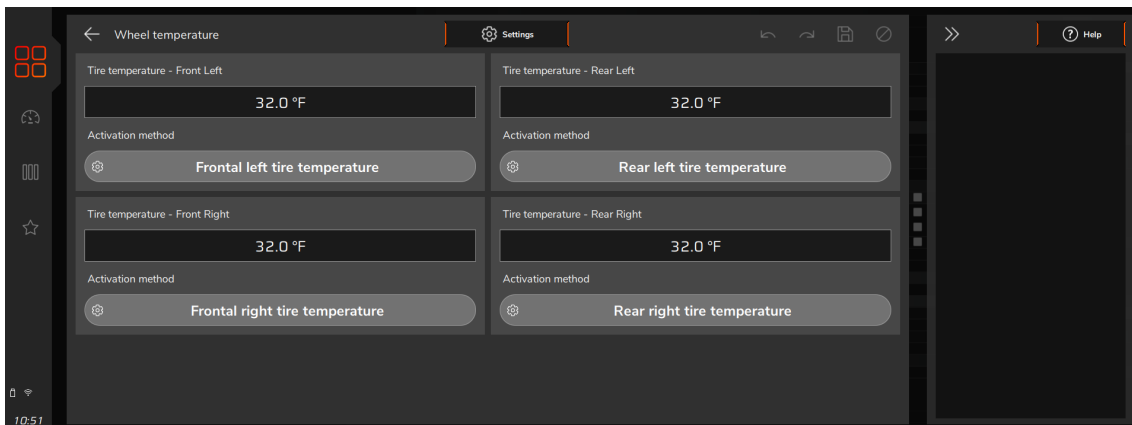

## 15.29 Track temperature

Allows to monitor track surface temperature using a laser sensor with either an ETM-1 wired into a white input or an EGT-8 via CAN.

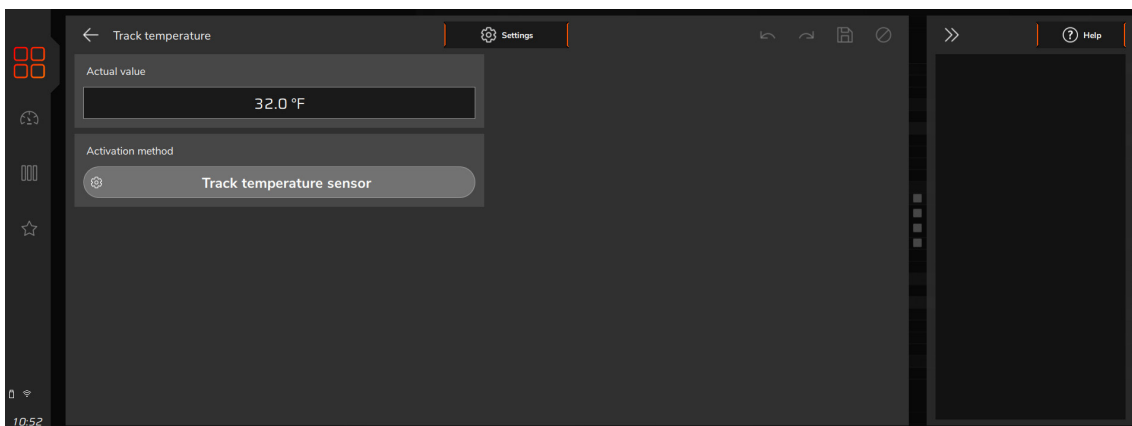

### 15.30 Water pressure

This function it is possible to configure a sensor for monitor of the pressure to the engine cooling system. Set the sensor used if necessary, to adjust the offset.

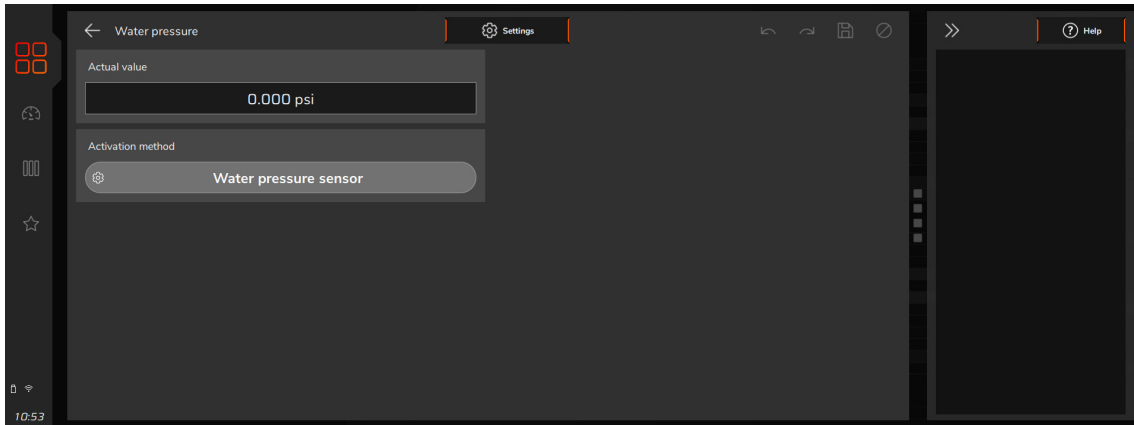

### 15.31 Turn signals

Set an input for each turn signal (left and right) and whether it'll be activated at 0V or 12V. Go to "Interface settings" and then "Side LEDs" to set up LEDs for each one of them.

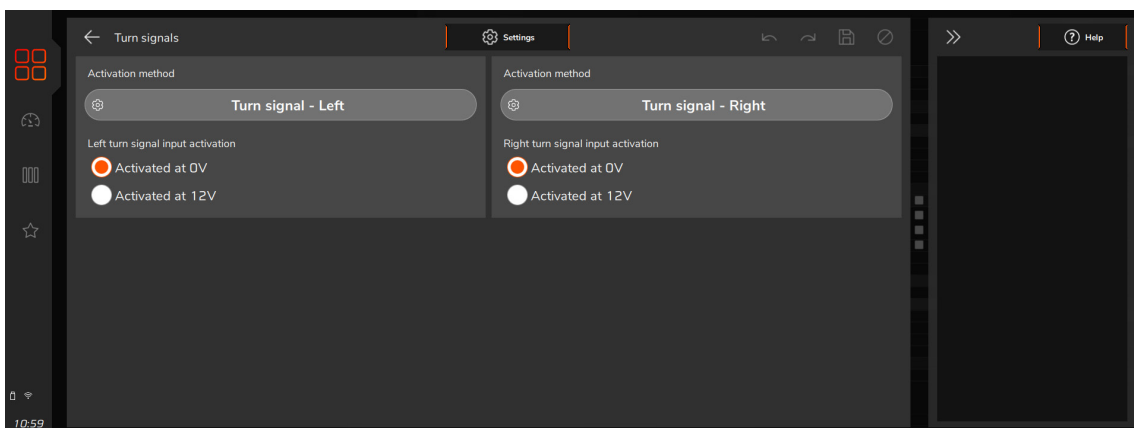

### 15.32 Low beam / High beam

Set one input for the low beacon and one for the high beacon, set whether the drive will be 0V or 12V. Access the "Interface Settings" menu then "LED Configuration" to adjust the high and low headlight drive indication LED.

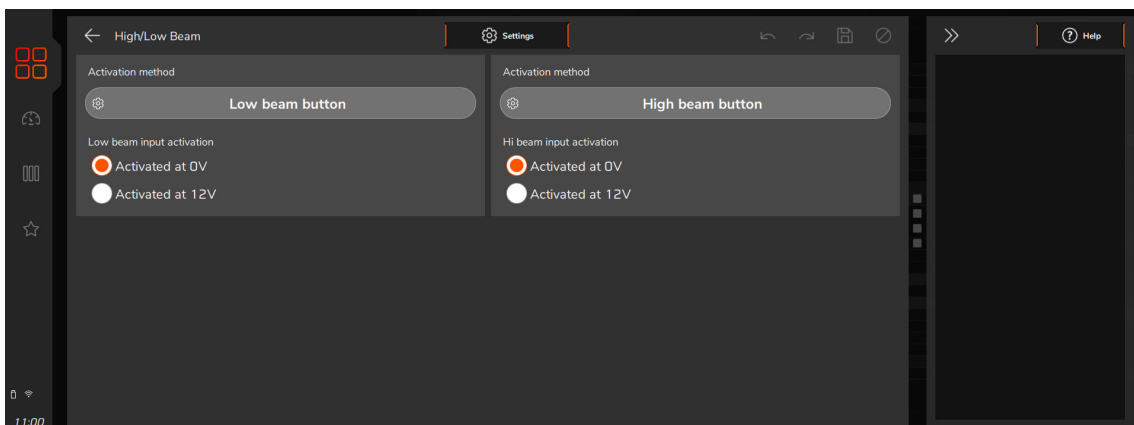

### 15.33 Turbo speed RPM

This feature reads the turbocharger compressor wheel speed. In order to use it a white wire input must be set as Turbocharger RPM.

Set the internal divisor (provided by the manufacturer) and the number of blades of the compressor.

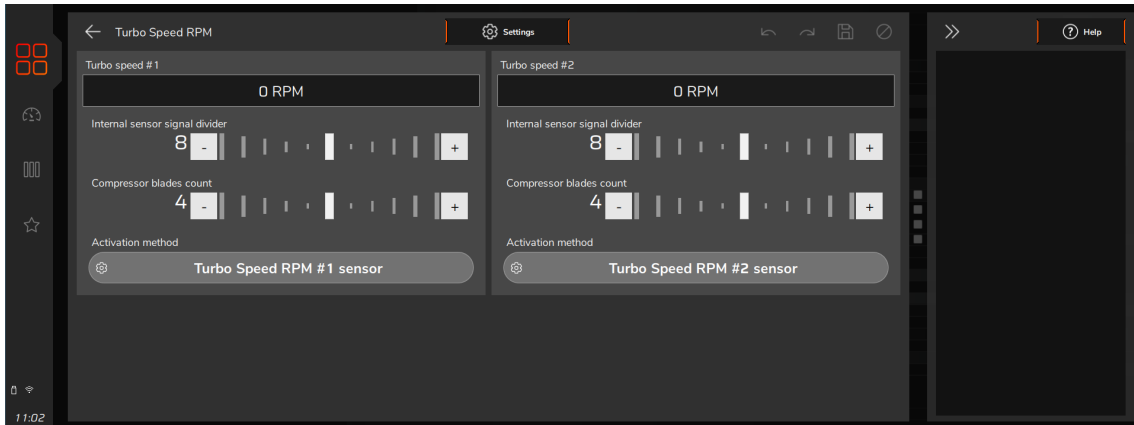

### 15.34 Fuel flow

Any sensor configured will be shown in the unit display and/or recorded in the datalogger, to display fuel consumption, at least 1 sensor in the pressure line and 1 in the return line is needed. In the event of having 2 separated fuel feeds, like blower hat and intake runners, it is required to have 4 individual sensors to be able to measure fuel delivery per line.

**Fuel flow pump A:** Pulses from the sensor to measure 1 US Gallon, so its possible to evaluate pump A fuel flow in the log.

**Fuel flow pump B:** Pulses from the sensor to measure 1 US Gallon, so its possible to evaluate pump B fuel flow in the log.

**Fuel flow return A:** Pulses from the sensor to measure 1 US Gallon, so its possible to evaluate fuel flow return A in the log.

**Fuel flow return B:** Pulses from the sensor to measure 1 US Gallon, so its possible to evaluate fuel flow return B in the log.

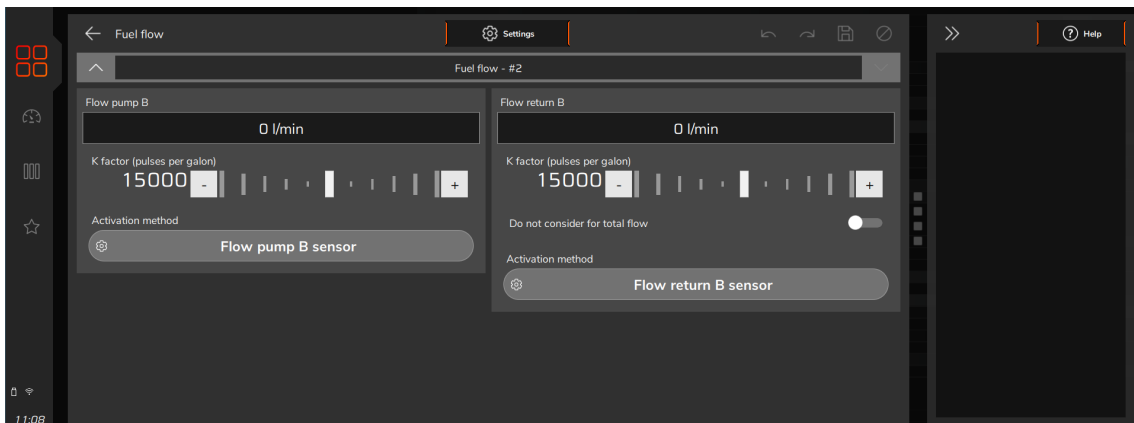
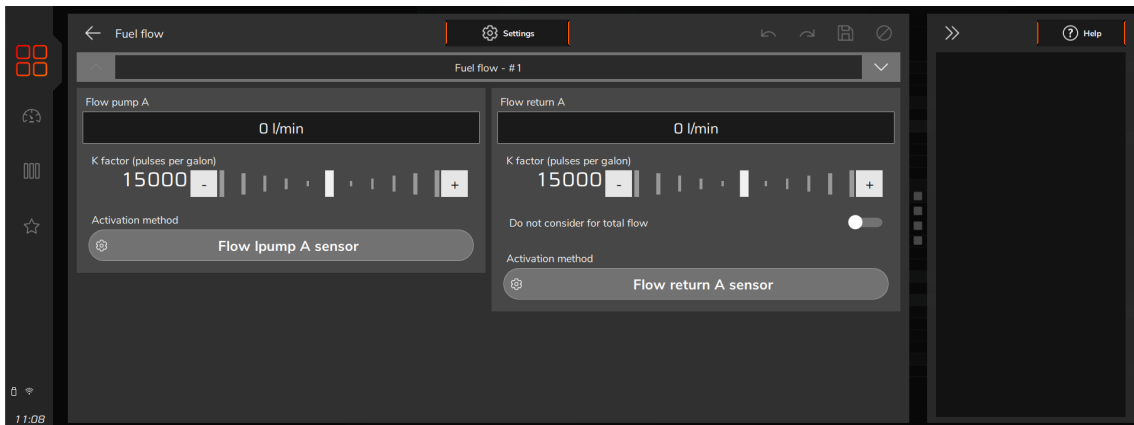

### 15.35 Flywheel RPM (Clutch basket)

Used primarily on motorcycles that have a gear ratio between the crankshaft and the input shaft/clutch basket. To use this feature in a car, a 1:1 ratio must be used.

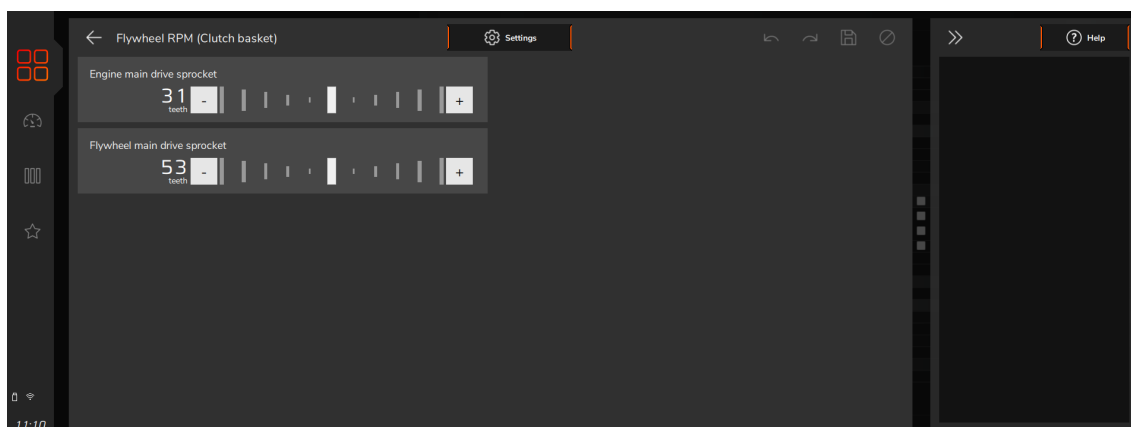

### 15.36 Battery temperature

This function configures a sensor to monitor the temperature of the battery.

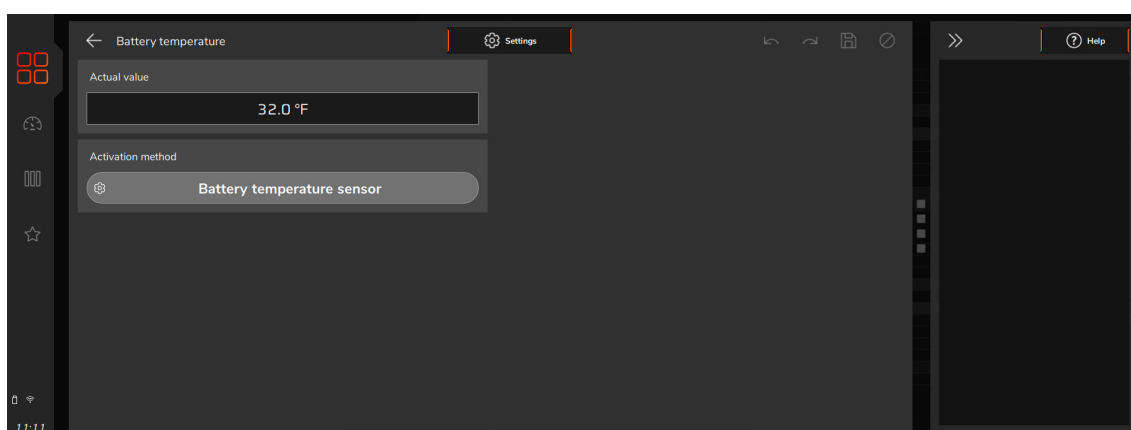

### 15.37 Automatic transmission range selector

This setting is required so the VCU can associate the inputs to the shifter position. The automatic transmission controller applies the parameters set in this tab to control the transmission.

There are four different settings: Digital, Analogical voltage level, CAN 2.0 Network and Duty cycle (PWM).

#### Digital

This option is the most complex to set up and requires some attention. The first step is to select which inputs correspond to each shifter position.

**Input activation:** This is directly related to the previous settings and assumes that if “Activated at 0v” is selected, then all the options with a checked box will be activated at 0v. If “Activated as 12v” is selected, then all checked boxes will be activated at 12v

**Inputs position configuration:** After checking the boxes to all shifter positions, select which inputs will be assigned to each position.

**For example:** For “D” position, A and B inputs will be activated. For “N” position, only input “B” will be activated and so on.

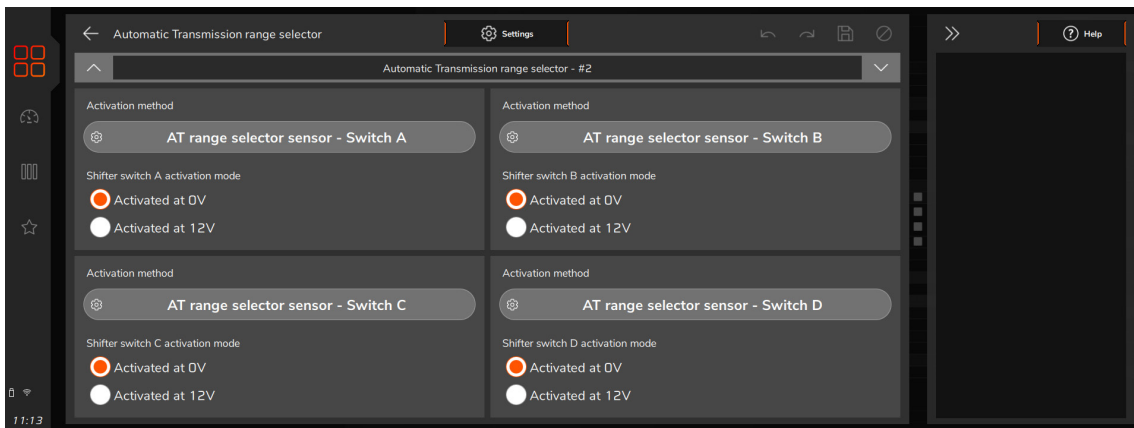
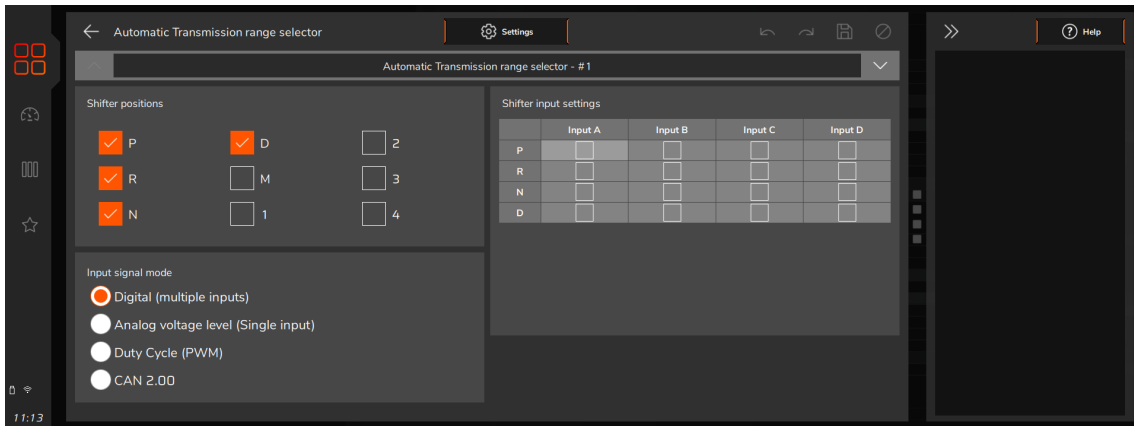

**Analogical:** This option must be used when there is only one input (white wire) dedicated for the VCU to identify the shifter position. The shifter sensor must be a potentiometer that will vary the voltage and therefore send different values for the VCU according to each position. Each voltage must be set up in the VCU, as well as each detection window between the positions.

**Duty cycle:** This option can be used when there is only one input (white wire) identifying the shifter positions through a PWM percentage. To set this up, it's necessary to set up the input, define the shifter positions, adjust the Duty cycle percentage for each position and set the detection window around each percent.

**CAN 2.0 Network:** This option allows the use of a SwitchPanel to select gears. After the positions are selected, you must set a SwitchPanel button to activate each one.

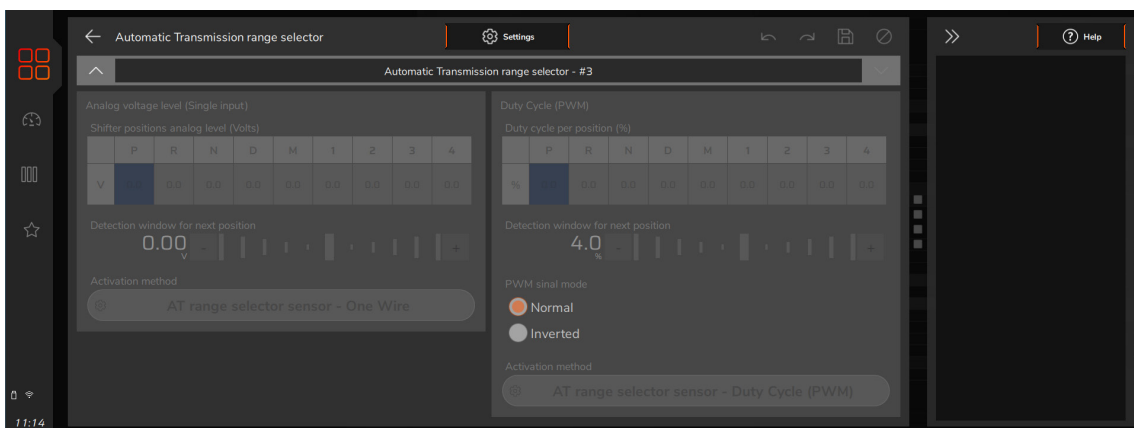

### 15.38 Paddle Shift

This option allows the driver to perform gear shifts by paddle shifters. You must set up an input for up-shifts and another for downshifts.

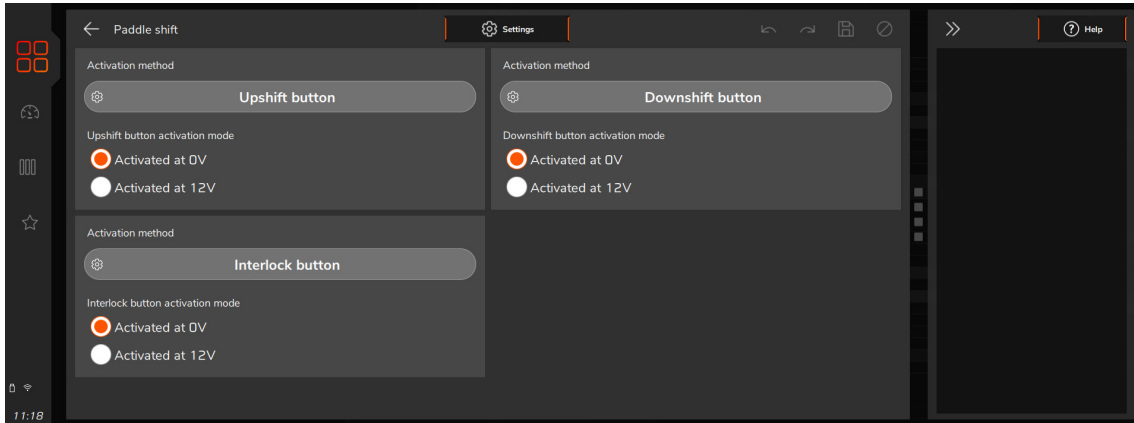

### 15.39 Brake

This function is related to the Lockup system. A sensor can be used to read the line pressure and adjust a ON and OFF range or just a brake switch to activate/deactivate the Lockup.

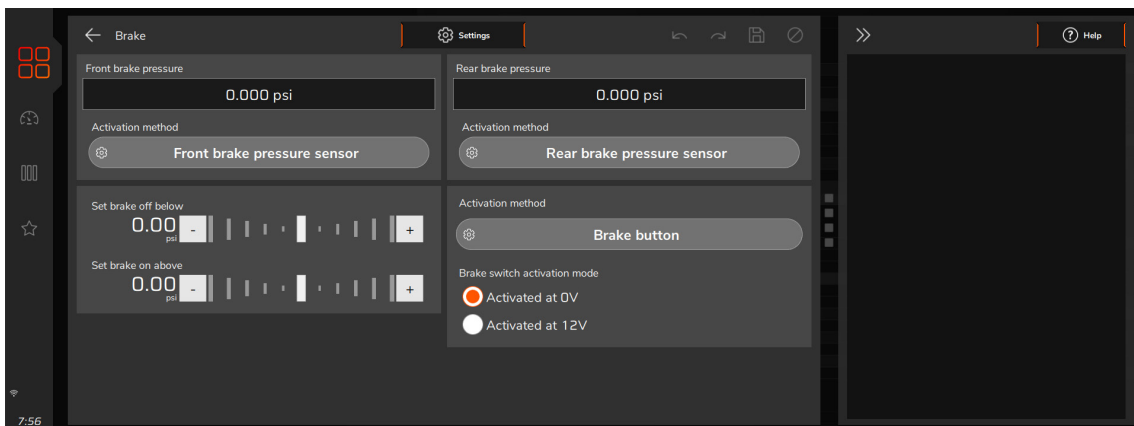

### 15.40 Compressed air pressure

This function monitors the pressure in a compressed air tank, very useful for vehicles equipped with pneumatic gearboxes.

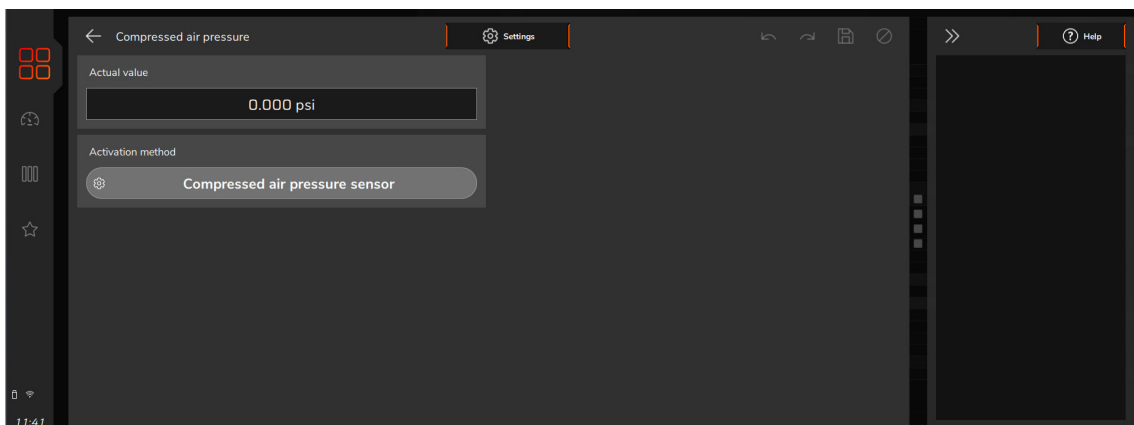

### 15.41 Internal lambda probe conditioner 1 and 2

This function allows you to read up to two probe conditioners integrated in the FT700.

**Sensor type:** Select which Lambda sensor is used, there are four options: Bosch LSU 4.2, Bosch LSU 4.9, Bosch 5.2 and NTK

**Outdoor calibration voltage:** this option is for NTK sensors that require a specific calibration procedure

**Heating mode:** allows you to adjust the heating current for the probe

**Normal:** standard heating currently used by the WB-O2 NANO. This is the recommended mode for FuelTech, ensuring a longer probe lifespan.

**Fast:** fast heating, uses a high current to reduce heating time. When using this option, the probe lifespan will be drastically reduced

**Current limit:** Limits the heating current to 2, 2.5 and 3mA.

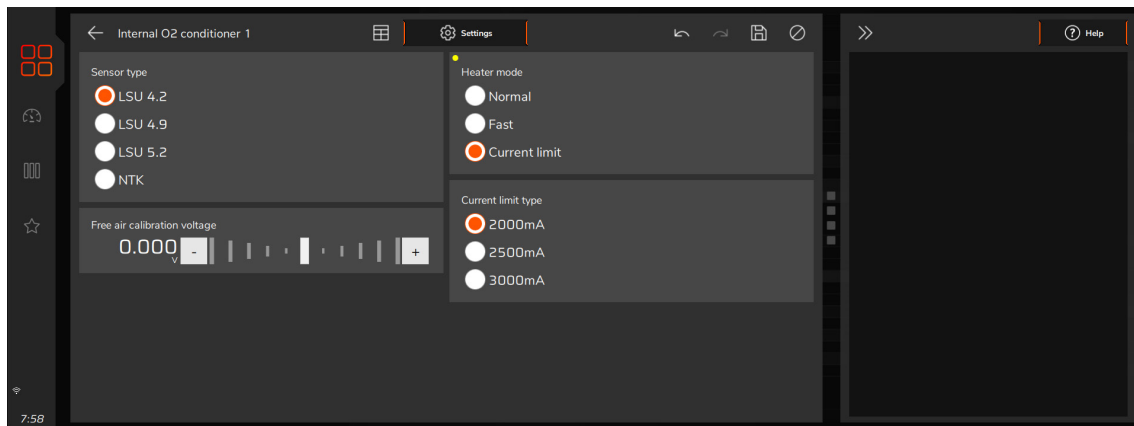

### 15.42 Brake disc temperature

This function was developed to monitor the operating temperature of the brake discs. This control helps to increase their useful life and prevent possible future problems.

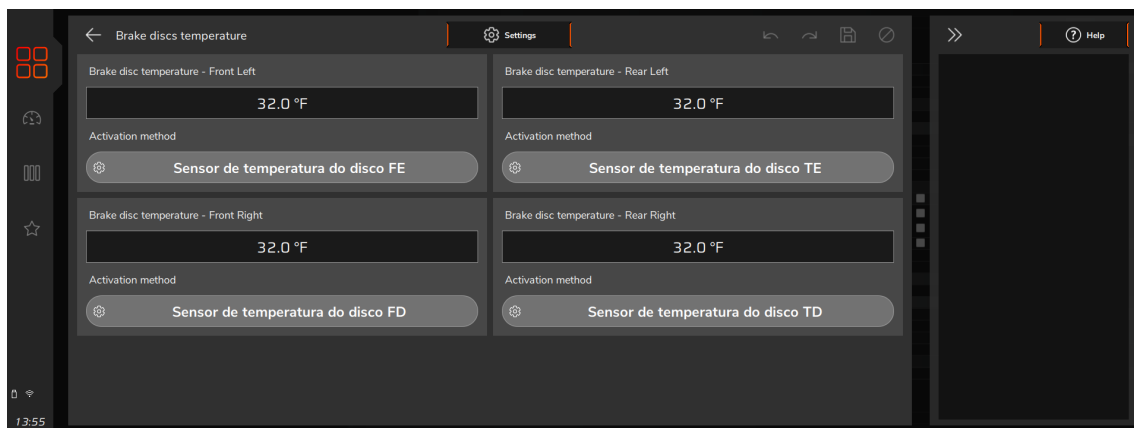

### 15.43 BlowOff Position

This function allows you to monitor the position of an electronic BlowOff valve.

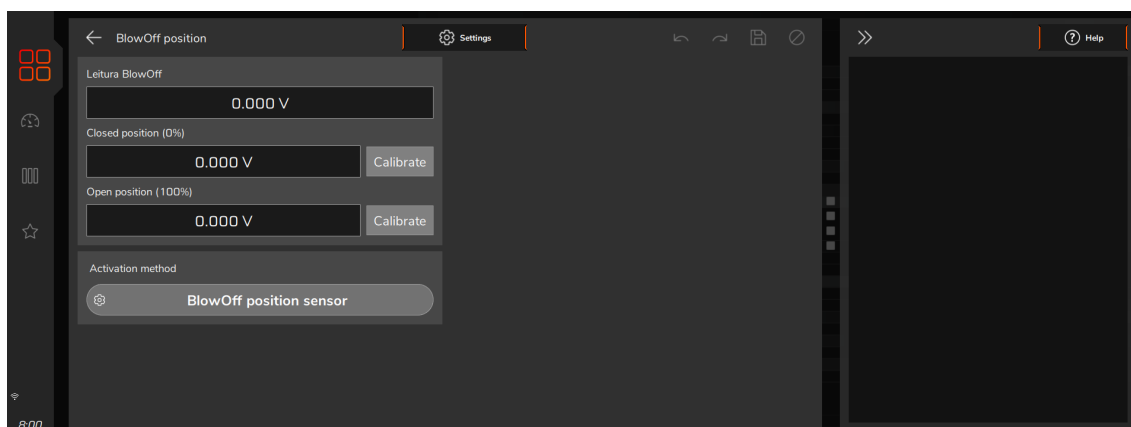

### 15.44 Fuel consumption control

The Fuel consumption control function allows the ECU to estimate engine consumption in 2 different ways:

- **By fuel flow and injection time:** calculation of fuel consumption based on injectors opening time during engine operation.

- **By fuel flow sensor:** a flow sensor is needed in the fuel supply line from the tank and another in the return to calculate the amount used by the engine.

**Calibration factor:** the calibration factor exists so that it is possible to compare and correct possible differences between the consumption value calculated by FuelTech and the amount of fuel really consumed, since information such as flow and deadtime of the injectors have a great influence on the calculations and are usually difficult to parameterize very precisely. If the calculated consumption is lower than the real consumption, a calibration factor greater than 1.000 must be applied, if the calculated consumption is greater than the real consumption, a correction factor smaller than 1.000 must be applied.

Fuel specific gravity is a very important part of the fuel consumption calculation. The default mode considers the fuel selected in the Injection menu. When the Flex Fuel function is enabled, the sensor reading will interpolate the specific gravity according to the % ethanol in the fuel, not being possible to change specific gravity for custom numbers. If it is necessary to use a specific gravity value different from the standard fuels, it is possible to customize this number by selecting the Custom fuel specific gravity option.

Pre-set specific gravity for the selected fuel:

Ethanol: 0.809 g/cm<sup>3</sup>

Pump gas: 0.730 g/cm<sup>3</sup>

Race gas: 0.715 g/cm<sup>3</sup>

Methanol: 0.792 g/cm<sup>3</sup>

The Fuel consumption control function can be used as an on-board computer, showing information on Total fuel consumption, Real time fuel consumption, Average fuel consumption and Estimated Range on the dashboard and in the log.

To calculate the estimated range, it is necessary to select how the fuel level is indicated.

- **By fuel consumption calculation:** from the indication of the tank capacity in the specific field, the ECU considers that when the consumption counter is reset, the tank will be full, and the remaining volume is obtained by subtracting the total consumption of tank capacity. This means that the engine consumption calibration needs to be consistent with the real consumption, avoiding incorrectly informing range or remaining volume of fuel.

- **By fuel tank level sensor:** the fuel level is measured by the sensor in the tank which is connected to FuelTech on an analog input and must be calibrated to indicate the correct volume.

The estimated range considers the average fuel consumption so far to calculate the distance that can still be covered until the end of fuel volume present in the tank.

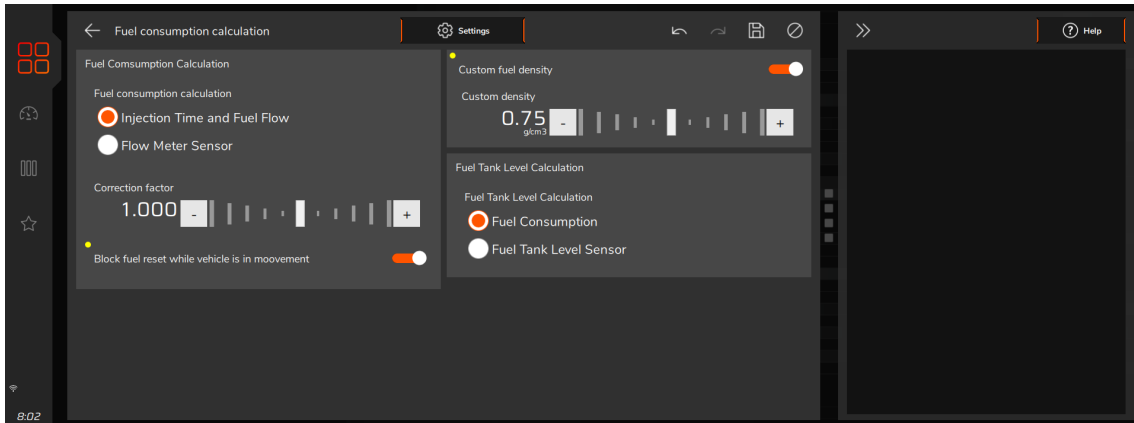

### 15.45 Fuel level

The fuel level is measured by the sensor in the tank which is connected to FuelTech on an analog input and must be calibrated to indicate the correct volume.

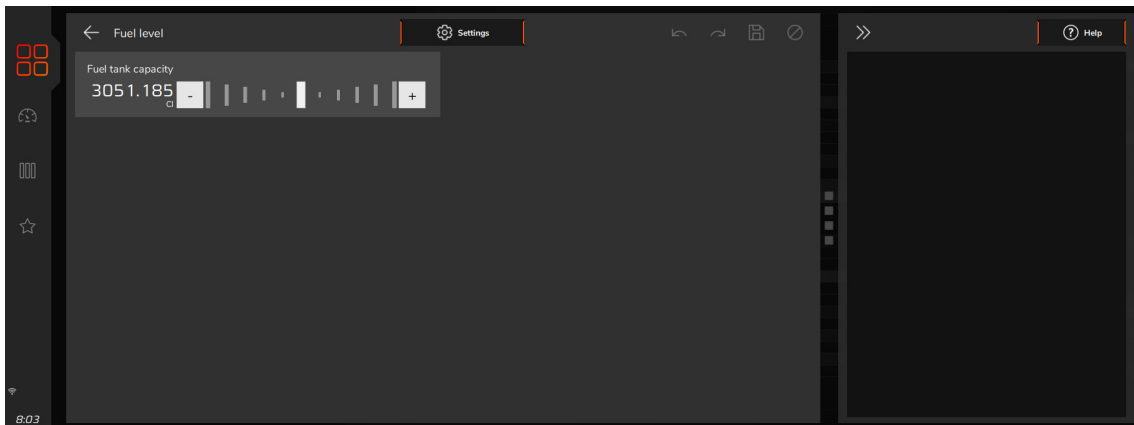

### 15.46 Blow by pressure

This function allows you to monitor the engine blow by pressure.

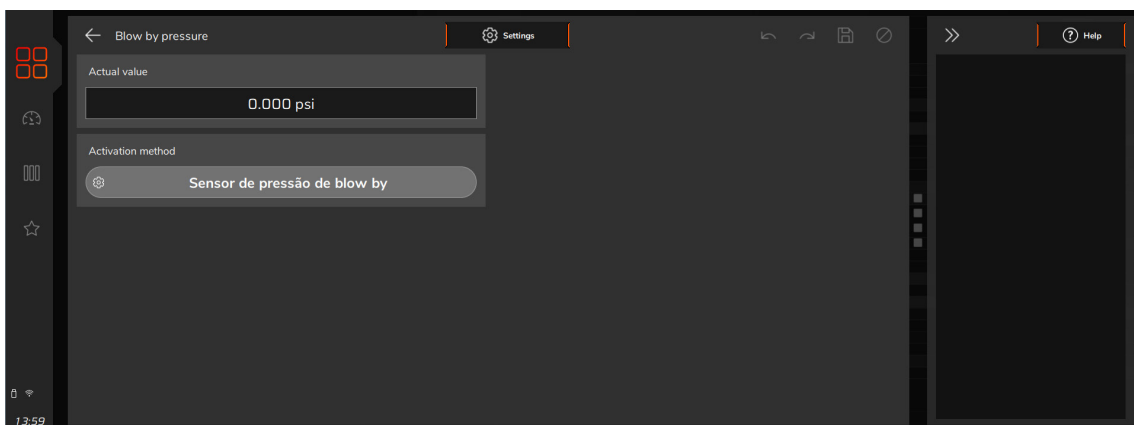

### 15.47 Strain Gauge

Sensor required to use GearController function.

**Strain gauge:** a sensor installed directly on the gear lever in cars or on shifter pedals on motorcycles. This sensor is installed by our service department. When the function is activated, the white inputs (19 and 20) will be associated as lever sensor inputs.

**Gear shifter sensor gain:** This parameter adjusts the ECU's sensitivity to receiving the sensor signal. This value can be set from 300 (least sensitive - will require more force to register the value) to 9600 (most sensitive - will require less force on the lever to register the variation). If the signal easily reaches the stops (5V or 0V), adjust the sensor sensitivity so that the lever voltage signal gets close, but never reaches them.

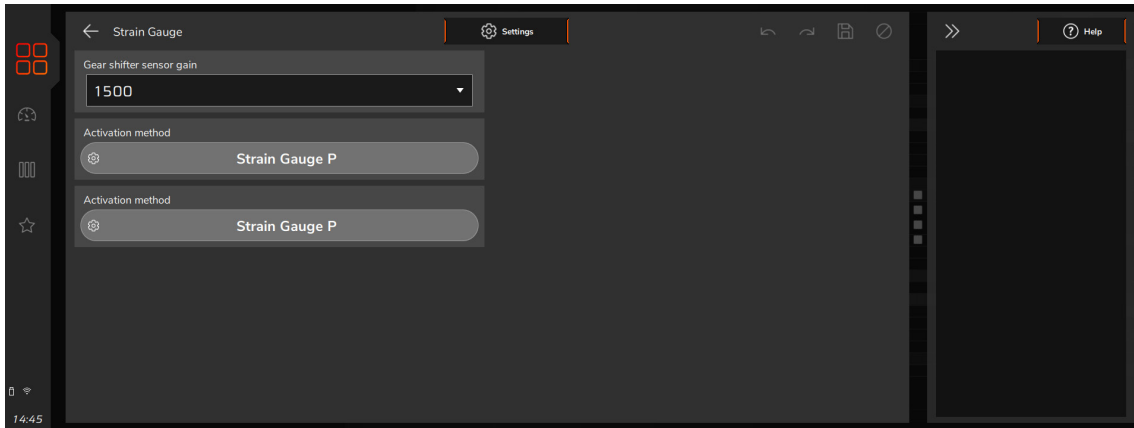

### 15.48 VR inputs

Allows you to configure the VR input voltages.

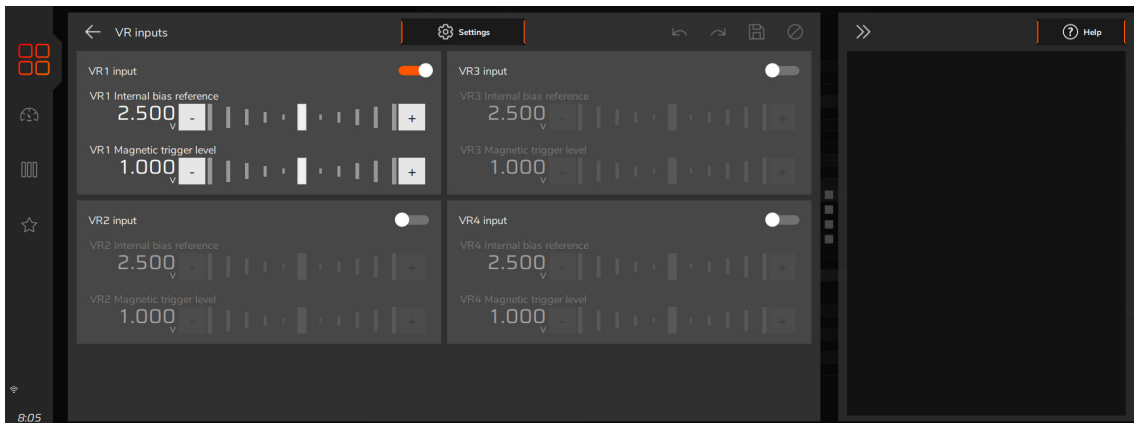

## 15.49 Sensors VE

This function is only available when the “*VE Based*” option is selected in the “*Engine Settings/Engine Settings*” menu. These sensors are essential for the map to function correctly.

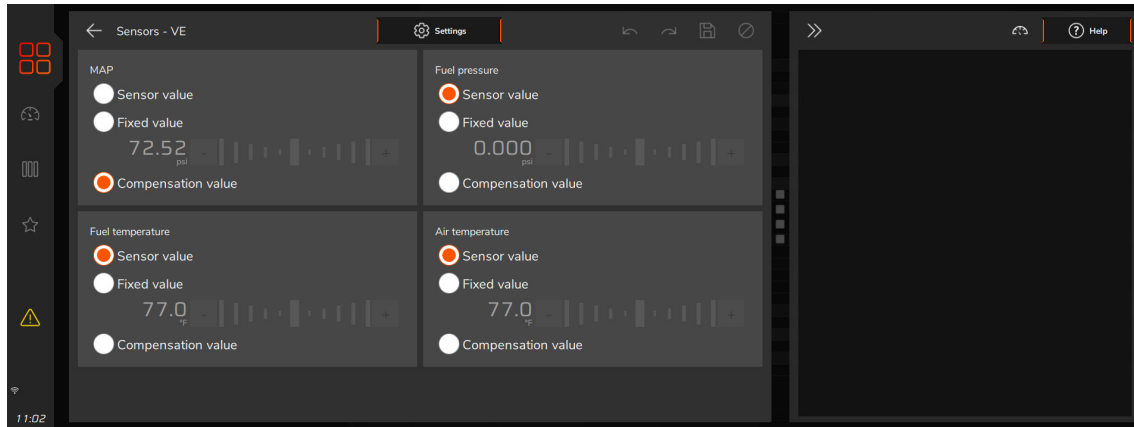

A large green line-art graphic on a dark background. It features two overlapping circles. The inner circle contains a stylized 'V' shape. A line extends from the top right of the outer circle towards the top right of the page. Another line extends from the bottom of the outer circle down to a vertical rectangular shape at the bottom left of the page. A solid green horizontal bar is located at the bottom right of the page.

# ***DATALOGGER***

## 16. Datalogger

The FT700 allows you to generate, analyze and edit logs directly on the VCU screen, or even pair with desktop and smartphone software for cross-platform analysis at the same time.

### 16.1 VCU Logs

These logs are stored in the internal memory of the VCU. A log file is generated when the conditions configured in the settings menu are validated. To rename, copy or delete a log just click on the three dots (1) in the upper right corner of the file which will open the menu.

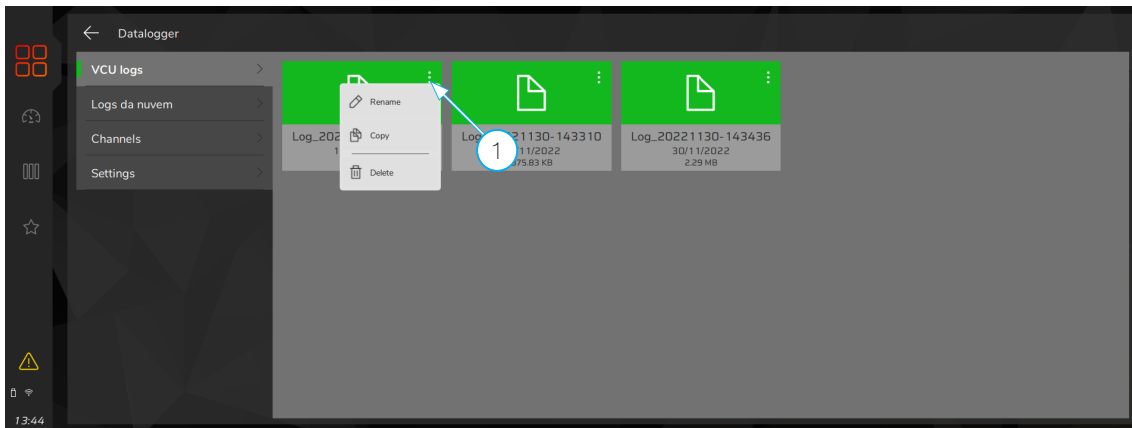

### 16.2 Cloud Log

Creates a cloud log file (Internet folder). To start the cloud log, the configured conditions must be met and the button (2) of the connectivity bar must be activated. From this point on, the log will be generated and sent to the cloud and will also be available in the VCU memory.

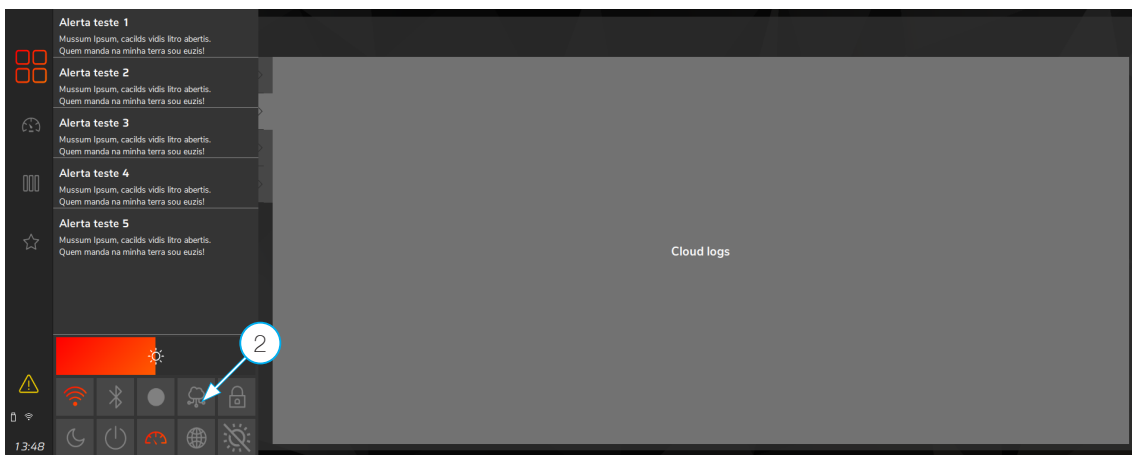

### 16.3 Channels

This tab shows all channels available for recording in a log, and the settings made on this screen will be the defaults for all generated logs.

**Record:** Defines whether or not the channel will be recorded in the log. It is also possible to check/unchecked them all at once by clicking on the button (3).

**Name:** Displays the name of the channel. This name is editable.

**Sampling Rate:** defines the quality of the channel recorded in the log. The higher the sampling rate, the more accurate the graph will be, on the other hand, the time available for recording will be less. For competition vehicles, mainly drag racing, it is interesting that the accuracy of the log is as high as possible, depending on the hit or to detect a possible failure in a specific point of the map. It is enabled only when the Individual sample rate per channel option is selected in the settings menu.

**Group:** Shows the group the channel belongs to. It can be changed between 10 groups of your choice.

**Order:** Defines the order in which the channel will be shown within the group.

**Visible:** Select whether the channel will appear in the log. It is possible to record the channel in the log but it is not necessary to make it visible, this facilitates the analysis of the log by reducing the information shown in the graph.

**Minimum and Maximum:** Adjusts the minimum and maximum values for each channel

**Smoothing:** Allows you to add smoothing to the value recorded in the log. There are four OFF levels, low, medium and high.

**Color:** adjusts the color of the channel in the log.

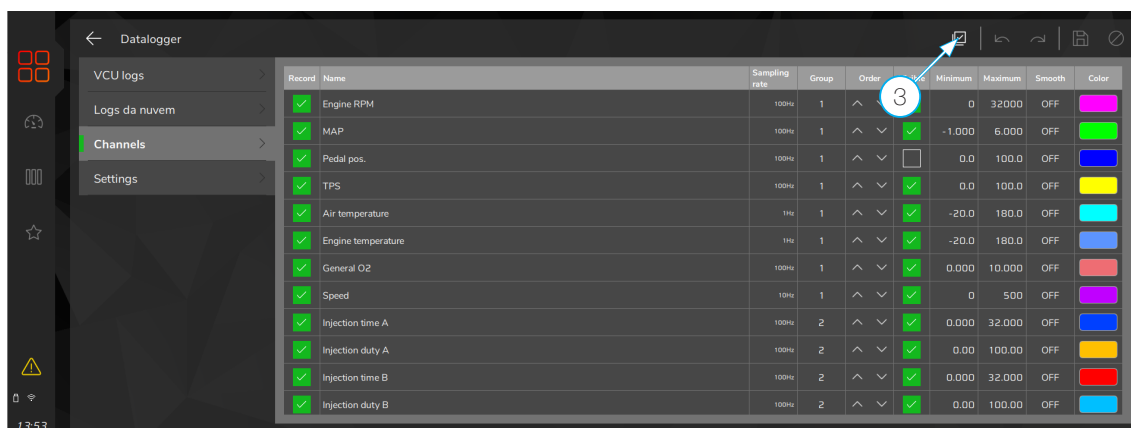

## 16.4 Settings

**Activation method:** Select if the datalogger will be activated or not and configure the way to start and stop the log manually. The possibilities for manual activation are: white input, CAN, dash button, Bluetooth, Ethernet, wi-fi and smart trigger.

**Automatically start or finish log:** Datalogger recording can start and end automatically by desired speed or rotation signal. It starts when the engine/vehicle rotation or speed is higher than the configured one.

When the rotation or speed read is lower than what was configured, the recording ends. Recording is also stopped if the memory fills up or if the module is turned off.

**Sampling Rate:** The sampling rate defines the quality of the Log. The higher the sampling rate, the more accurate the graph will be, on the other hand, the time available for recording will be less. For competition vehicles, mainly drag racing, it is interesting that the accuracy of the log is as high as possible, depending on the hit or to detect a possible failure in a specific point of the map.

This rate is fixed for all log channels. It is possible to set different rates for each channel by checking the option “Individual sampling rate per channel”

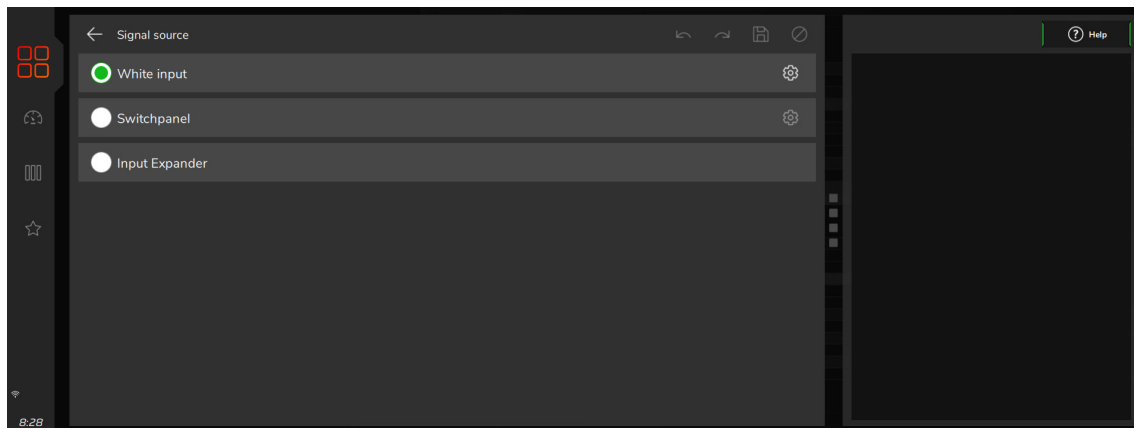
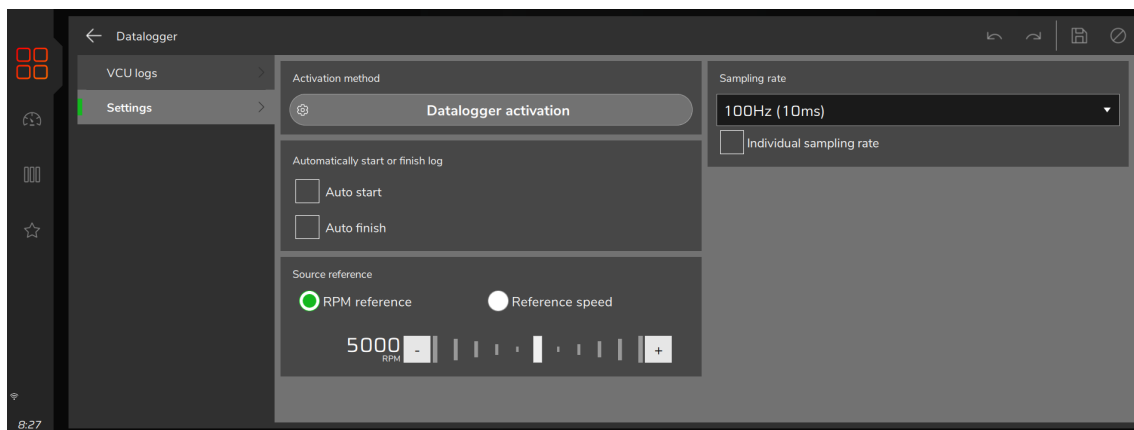

## 16.5 Log interface

The log interface is very similar to the FTManager software, we have three distinct areas to analyze.

- 1 - **Log area**
- 2 - **Timeline**
- 3 - **Channels current values**



There is a bar with three buttons in the upper right corner of the log screen.

- 4 - **Zoom button +**
- 5 - **Zoom button -**
- 6 - **Options button:** in this button there is a menu with several options
  - **Set origin:** defines the point of origin of the log. This will become time 0 seconds.
  - **123 values:** displays the log channels with the values referring to the log position at the current time.
  - **Status events:** shows the errors recorded in the log
  - **Minimum and maximum:** shows the minimum and maximum values of each channel.
  - **Settings:** opens the channel settings screen. This screen is exactly the same as the datalogger function settings screen, however with a caveat that the settings made in this menu will only be applied to this log.



## 17. Datalogger in VisionFT Software

VisionFT Software provides a complete experience for analyzing logs directly in the map editing software, unlike what was presented in the FTManager software where the Datalogger is a separate program. There is a more basic version of viewing logs directly on the VCU screen.

### 17.1 Opening a log

The main screen of the VisionFT software displays all the maps, logs and folders available on the computer. To open a log, simply select the desired file. A confirmation window will then appear to validate the opening action.

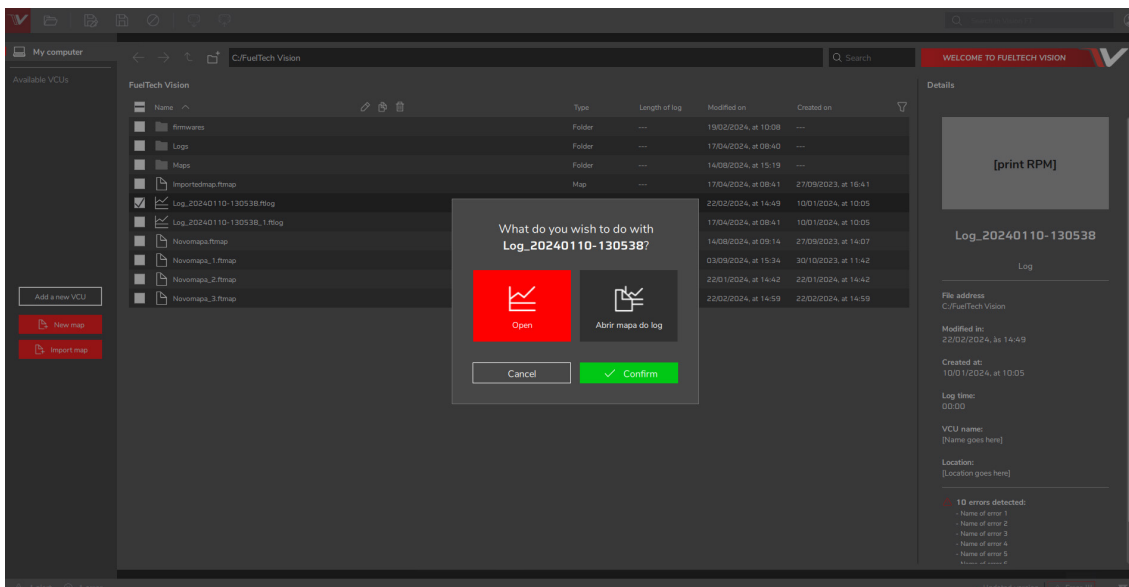

## 17.2 Settings

This tab displays all channels available for recording in a log, and the settings made on this screen will only be applied to the log opened in the graphics tab. To make standard changes to all logs, it is necessary to configure the parameters within the datalogger function in the “Channels” tab.

- 1 - **Visible:** Select whether the channel will appear in the log. It is possible to record the channel in the log but it is not necessary to make it visible, this makes it easier to analyze the log by reducing the information shown in the graph.
- 2 - **Name:** Shows the channel name.
- 3 - **Settings:** Opens a new window with the channel settings. On this screen, it is possible to customize the channel name, color, smoothing, scales, data conversion and offset.
- 4 - **Group:** Shows the group to which the channel belongs. It can be changed between 10 groups of your choice.
- 5 - **Order:** Defines the order in which the channel will be shown within the group.
- 6 - **Minimum and maximum:** Adjusts the minimum and maximum values for each channel.
- 7 - **Smoothing:** Allows you to add smoothing to the value recorded in the log. There are four levels: OFF, low, medium and high.
- 8 - **Color:** Adjusts the color of the channel in the log. Clicking on the color will open a new window with the color configuration options for this channel.

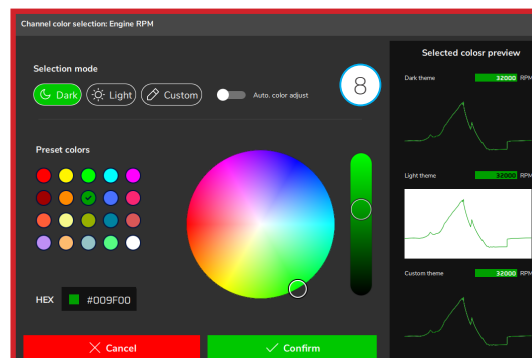
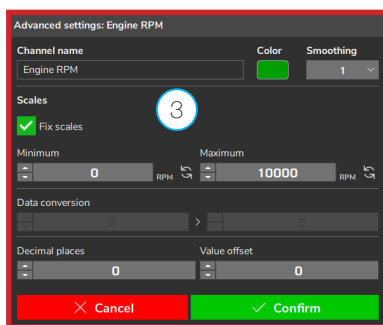

## Channel bar

- 09 - **Hide:** This button hides the information sidebar.
- 10 - **Channels left:** Allows you to position the sidebar on the left side, making the datalogger screen similar to the FTManager version.
- 11 - **Channels right:** Allows you to return the sidebar to the right side along with the minimum and maximum tab.
- 12 - **Channels top:** Allows you to position the bar at the top of the screen. In this configuration, the channels will be positioned side by side, freeing up viewing area for analyzing the log information.
- 13 - **Channels:** Lists the channels available in the log with their respective values. There is the option to quickly change the channel color. Just right-click on the channel color within the bar to cycle through different colors.
- 14 - **Minimum and maximum:** Allows you to view the minimum and maximum values of each channel recorded in the log.
- 15 - **Import settings:** Imports the configuration from another log.
- 16 - **Disable zeros:** Hides channels without a numeric value.
- 17 - **Restore defaults:** returns the log to its original configuration.
- 18 - **Open, save and undo buttons:** allows you to open, save and undo changes to the log.

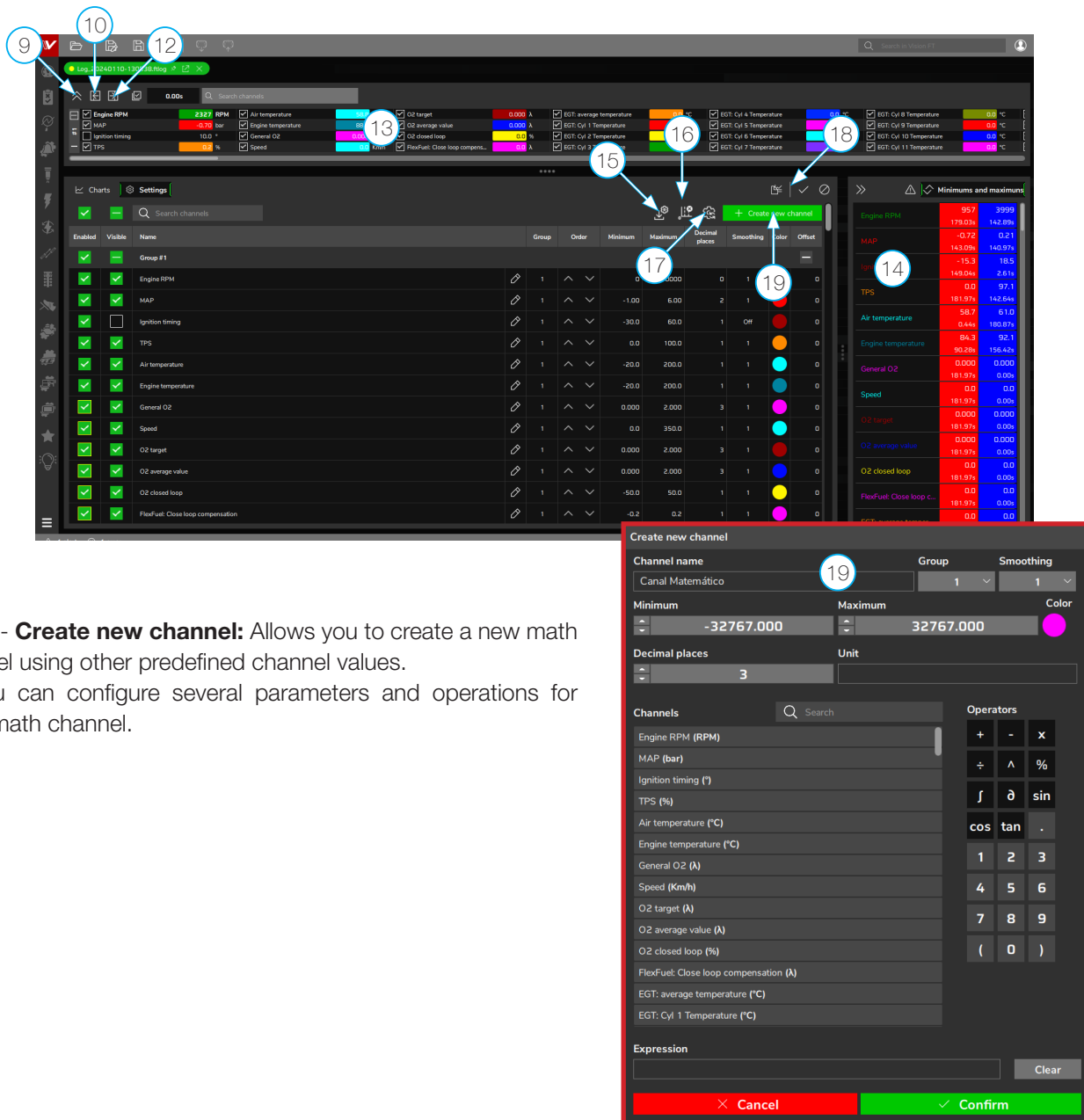

- 19 - **Create new channel:** Allows you to create a new math channel using other predefined channel values. You can configure several parameters and operations for each math channel.

### 17.3 Charts

This screen displays graphs for log analysis.

- 1 - **Zoom + and -**: Zooms in/out on the log.
- 2 - **Frame to origin**: Moves the chart view to the beginning or to the defined origin point
- 3 - **Set origin**: Sets a log origin time
- 4 - **Overlay**: Allows you to make adjustments and changes to the map directly on the chart. In this case, a screen will open below the chart area with parameter editing.
- 5 - **View in groups**: Separates the chart into groups. In this configuration, you can adjust the vertical size of the group. Simply position the mouse over the group separation line in the chart area and click and drag up or down to resize.
- 6 - **Save and Cancel button**: Saves and/or cancels changes. You can right-click on any area of the chart to open a menu where you will have options to set the origin, display values, channel names at that point, and the thickness of all chart lines.
- 7 - **Open map button**: Open map of the log.
- 8 - **Save and cancel button**: Save and cancel changes
- 9 - **Navigation time bar**: Marks the exact time in the log where the mouse is positioned. The side arrows allow you to move forward or backward in time in increments of 5 milliseconds, 1 second or 5 seconds.



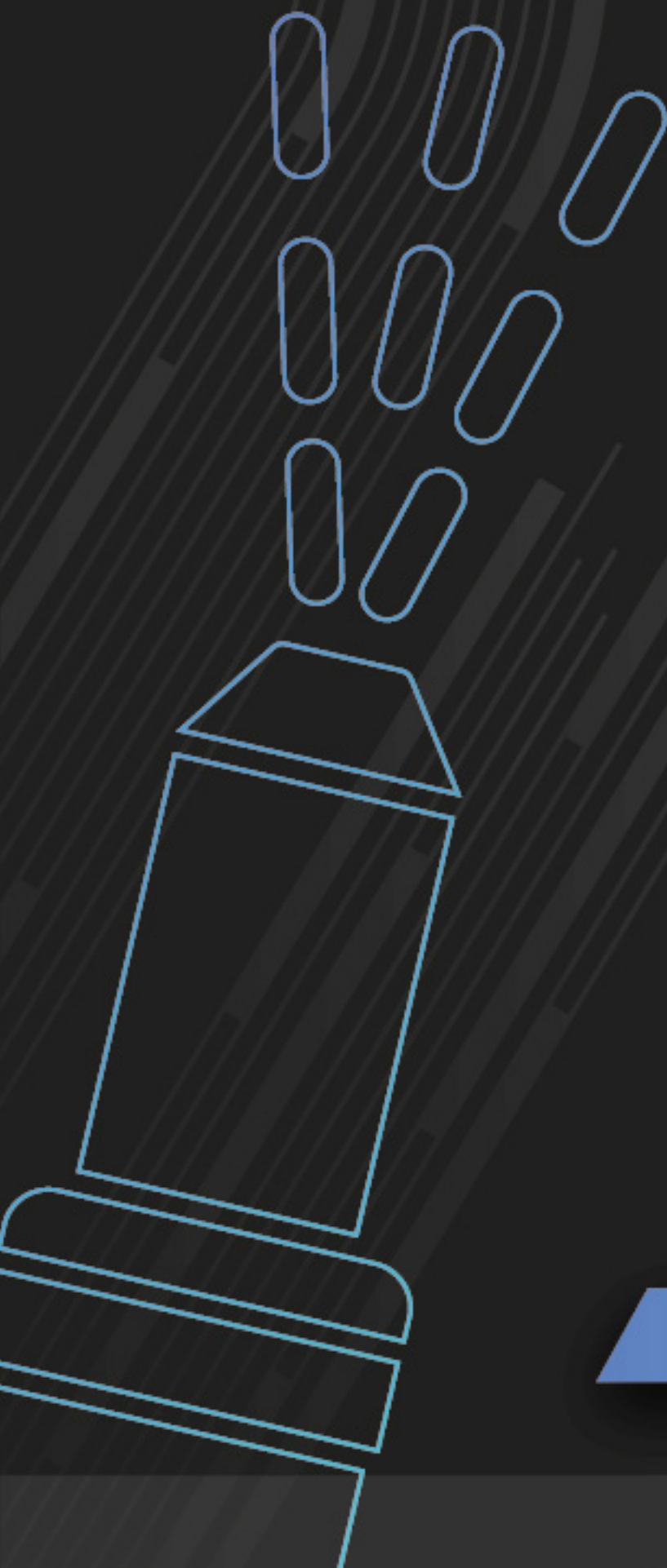

# ***INJECTION***

Tables



## 18. Fuel tables adjust

The main injection map functions by VE, Lambda and AFR will only be enabled if the “Fuel strategy” option is based on VE, to make this adjustment access the “Engine settings / Engine settings” menu.

### 18.1 Main MAP VE table (Volumetric Efficiency)

Volumetric efficiency is a measure of the performance of an internal combustion engine. It represents the relationship between the actual volume of air admitted by the engine and the theoretical volume that the engine could admit under ideal conditions. In other words, it is the ratio between the amount of air actually sucked into the cylinders during the intake cycle and the total cylinder capacity.

A volumetric efficiency of 100% means that the engine is admitting the maximum amount of air possible for its displacement volume. However, in practice, volumetric efficiency rarely reaches 100% due to various losses and limitations, such as intake system restrictions, heat loss and other airflow dynamics.

The standard speed interval is every 200 rpm up to 3000 rpm, above this speed range the interval is set at every 500 rpm up to maximum engine speed. The turbo vacuum and pressure ranges, throttle opening (TPS) and rotation can be modified via desktop software or directly on the VCU in a table with a resolution of (32x32) points, allowing for more precise adjustment of a specific region of the map.

To add or remove columns or rows, right-click (desktop) or long-click (VCU screen) on the column or row to edit it. It is also possible to invert axes and switch to other scales by pressing the upper left corner of the table (1).

 **NOTES**
▼

*Always check the continuity of the data, that is, avoid inconsistent values or those that form graphs with sudden variations. For any input to be efficient and correct on this map, it must necessarily form a graph with smooth lines.*



Main MAP VE table		Adjust															
		RPM (RPM)															
		0	500	800	900	1000	1250	1500	1750	2000	2500	3000	3500	4000	4500	5000	
MAP (psi)	%	43.6	46.3	48.9	49.7	50.6	53.7	58.0	62.2	66.1	74.0	81.6	90.4	97.3	101.9	104.1	
43.511	43.6	46.3	48.9	49.7	50.6	53.7	58.0	62.2	66.1	74.0	81.6	90.4	97.3	101.9	104.1		
40.611	43.6	46.3	48.9	49.7	50.6	53.7	58.0	62.2	66.1	74.0	81.6	90.4	97.3	101.9	104.1		
37.710	43.6	46.3	48.9	49.7	50.6	53.7	58.0	62.2	66.1	74.0	81.6	90.4	97.3	101.9	104.1		
34.809	43.6	46.3	48.9	49.7	50.6	53.7	58.0	62.2	66.1	74.0	81.6	90.4	97.3	101.9	104.1		
31.908	43.6	46.3	48.9	49.7	50.6	53.7	58.0	62.2	66.1	74.0	81.6	90.4	97.3	101.9	104.1		
29.008	43.6	46.3	48.9	49.7	50.6	53.7	58.0	62.2	66.1	74.0	81.6	90.4	97.3	101.9	104.1		
26.107	43.6	46.3	48.9	49.7	50.6	53.7	58.0	62.2	66.1	74.0	81.6	90.4	97.3	101.9	104.1		
23.206	43.6	46.3	48.9	49.7	50.6	53.7	58.0	62.2	66.1	74.0	81.6	90.4	97.3	101.9	104.1		
20.305	43.6	46.3	48.9	49.7	50.6	53.7	58.0	62.2	66.1	74.0	81.6	90.4	97.3	101.9	104.1		
17.405	43.6	46.3	48.9	49.7	50.6	53.7	58.0	62.2	66.1	74.0	81.6	90.4	97.3	101.9	104.1		
14.504	43.6	46.3	48.9	49.7	50.6	53.7	58.0	62.2	66.1	74.0	81.6	90.4	97.3	101.9	104.1		
11.603	43.5	46.2	48.8	49.6	50.5	53.7	57.9	62.2	66.0	73.8	81.4	90.2	97.1	101.7	103.9		

## 18.2 Fuel target tables

This tables allows you to define the AFR a value for each RPM x MAP or (TPS).

The standard RPM interval is every 200 rpm up to 3000 rpm, above this RPM range the interval is defined every 500 rpm up to maximum engine RPM. The turbo vacuum and pressure, throttle opening (TPS) and RPM intervals can be modified via desktop software or directly in the VCU in a table with (32x32) point resolution, allowing more precise adjustment of a specific region of the map.

To add or remove columns or rows, right-click (desktop) or long-click (VCU screen) on the column or row to edit it. You can also invert axes and switch to other scales by pressing the top left corner of the table (1).

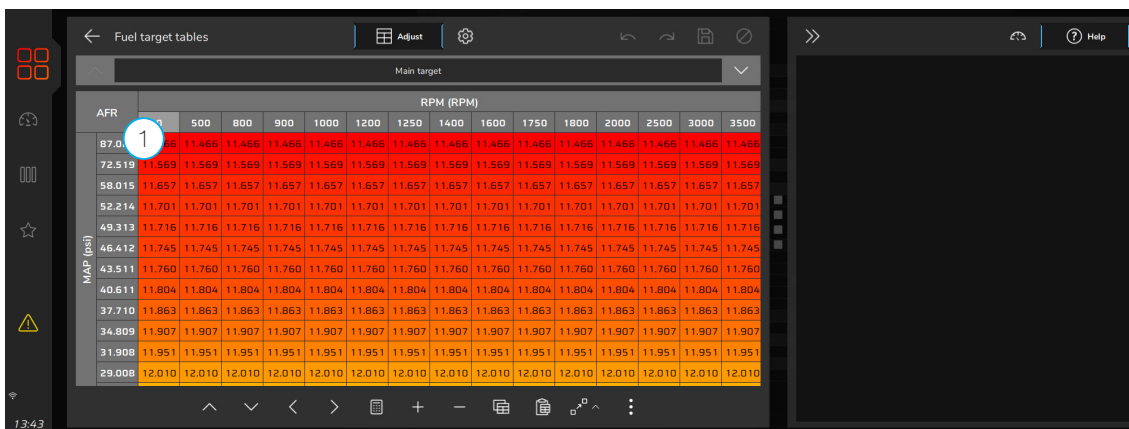

		Main target													
		RPM (RPM)													
AFR		500	800	900	1000	1200	1250	1400	1600	1750	1800	2000	2500	3000	3500
87.0	11.466	11.466	11.466	11.466	11.466	11.466	11.466	11.466	11.466	11.466	11.466	11.466	11.466	11.466	11.466
72.519	11.569	11.569	11.569	11.569	11.569	11.569	11.569	11.569	11.569	11.569	11.569	11.569	11.569	11.569	11.569
58.015	11.657	11.657	11.657	11.657	11.657	11.657	11.657	11.657	11.657	11.657	11.657	11.657	11.657	11.657	11.657
52.214	11.701	11.701	11.701	11.701	11.701	11.701	11.701	11.701	11.701	11.701	11.701	11.701	11.701	11.701	11.701
49.313	11.716	11.716	11.716	11.716	11.716	11.716	11.716	11.716	11.716	11.716	11.716	11.716	11.716	11.716	11.716
46.412	11.745	11.745	11.745	11.745	11.745	11.745	11.745	11.745	11.745	11.745	11.745	11.745	11.745	11.745	11.745
43.511	11.760	11.760	11.760	11.760	11.760	11.760	11.760	11.760	11.760	11.760	11.760	11.760	11.760	11.760	11.760
40.611	11.804	11.804	11.804	11.804	11.804	11.804	11.804	11.804	11.804	11.804	11.804	11.804	11.804	11.804	11.804
37.710	11.863	11.863	11.863	11.863	11.863	11.863	11.863	11.863	11.863	11.863	11.863	11.863	11.863	11.863	11.863
34.809	11.907	11.907	11.907	11.907	11.907	11.907	11.907	11.907	11.907	11.907	11.907	11.907	11.907	11.907	11.907
31.908	11.951	11.951	11.951	11.951	11.951	11.951	11.951	11.951	11.951	11.951	11.951	11.951	11.951	11.951	11.951
29.008	12.010	12.010	12.010	12.010	12.010	12.010	12.010	12.010	12.010	12.010	12.010	12.010	12.010	12.010	12.010

There are other tables that complement the controls for VE targets.

- **Engine temperature target:** creates a VE table for engine temperature.
- **Air temperature target:** adds a VE table for air temperature.
- **Time based target:** creates a time table for lambda targets.
- **Speed target:** adjusts a table for speed by MAP.

## Settings

**Minimum temperature:** Engine temperature for control start is the minimum engine temperature value for Lambda control to be activated.

**Smoothing for low load:** is the speed at which the control operates for low load situations, or low or constant speed. This function aims to reduce the speed of the control for situations where such fast operation is not required, in order to stabilize the lambda.

**Lock control:** The function to lock the control below or above certain speeds seeks to turn off the closed loop at pre-established speeds. Suitable for cases where the probe is very close to the end of the exhaust at low revs, and at high revs when the user does not want the system to act on the map after a certain rev.

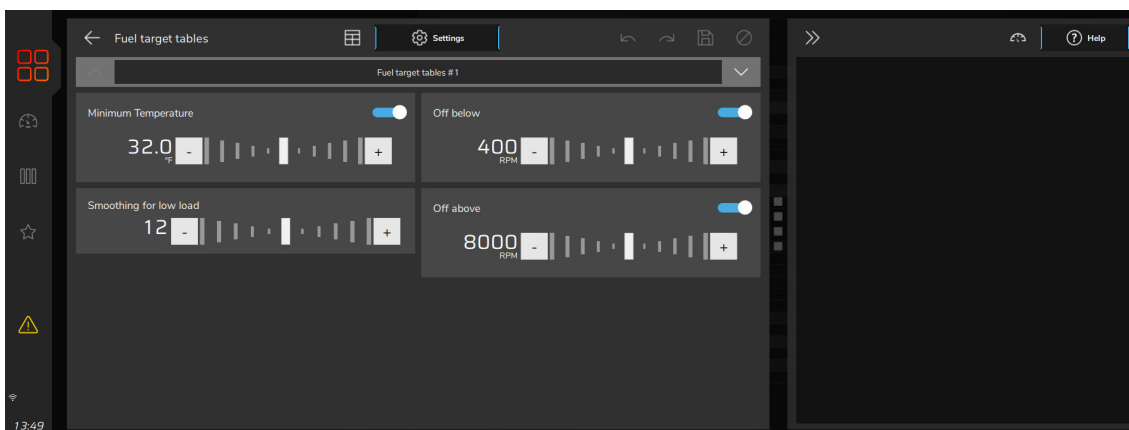

Fuel target tables #1	
Minimum Temperature	Off below
32.0 °F	400 RPM
Smoothing for low load	Off above
12	8000 RPM

**Behavior during acceleration fuel enrichment:** The protection function during rapid injection acts by turning off or freezing the closed loop operation for a time pre-defined by the user, this prevents the control from acting during the rapid time.

**Behavior during power reduction:** This protection acts in the same way as the previous screen but only when a gear change is detected.

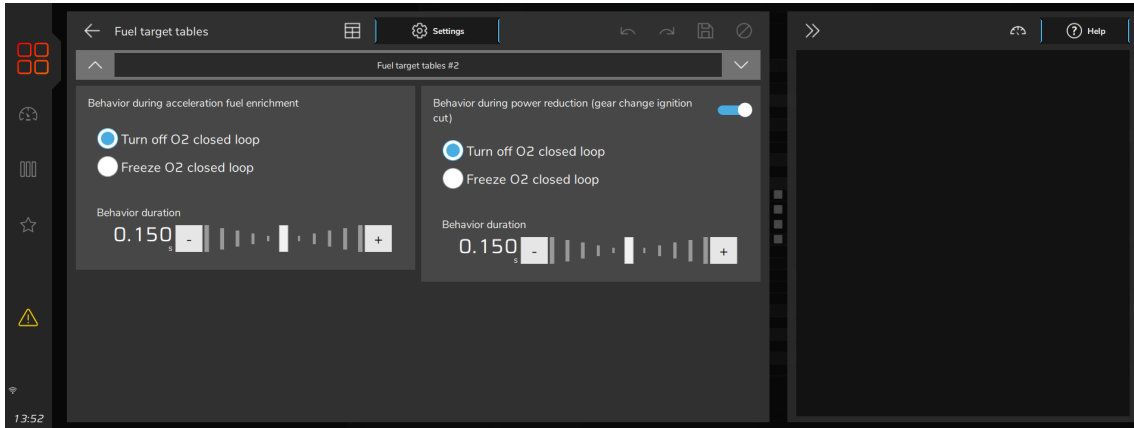

**O2 closed loop on Drag Race:** With the Target function in cut activated, the injection seeks the lambda value configured in cutting situations such as 2-step, 3-step, burnout mode, Anti-lag, Pops&Bangs and Engine Brake, regardless of pressure or rotation. When closed loop control is active, and the map is by TPS, the closed loop value for TPS can be set at 0%.

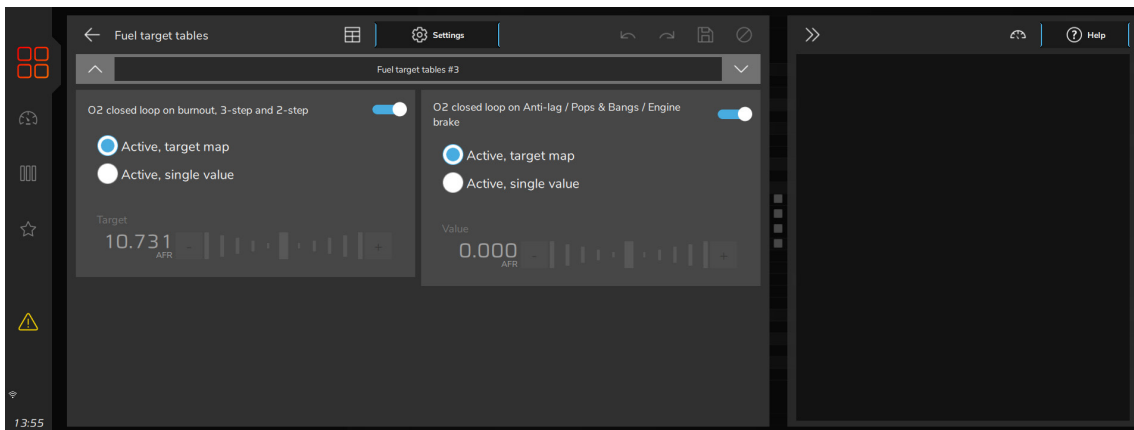

Adjusts the modes for setting the air and engine temperature tables and also the speed target.

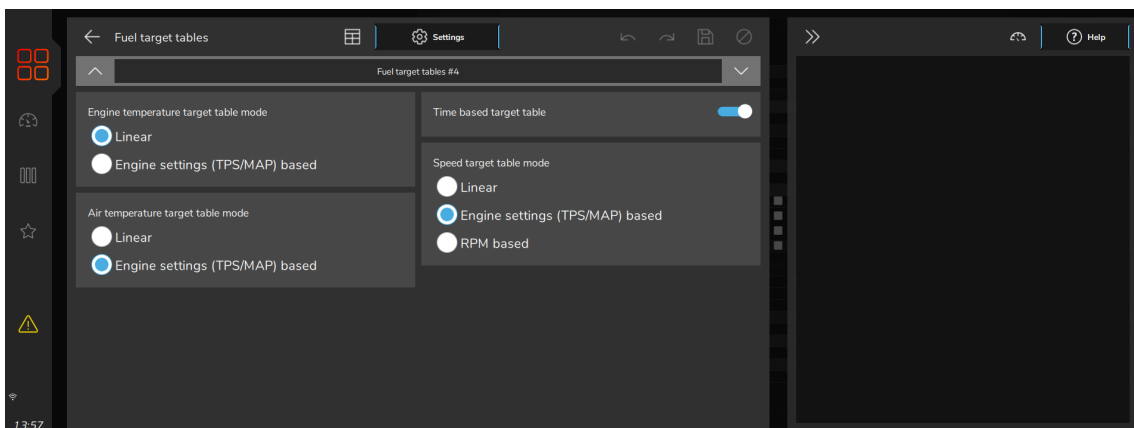

### 18.3 Exhaust / baro pressure compensation

This function is related to the VE map and allows you to create a baro pressure compensation, this value is in percentage by the MAP baro pressure ratio.



### 18.4 Injector staging

This is the duty cycle that this stage will freeze at and automatically begin ramping in the next stage until it reaches its staging duty cycle. Once all stages have achieved their staging duty cycle, all will then increase to 100% together as needed. You can manually ramp a stage of injectors in using the blend tables, however the staging duty cycle still applies. This helps prevent any possible lean conditions.

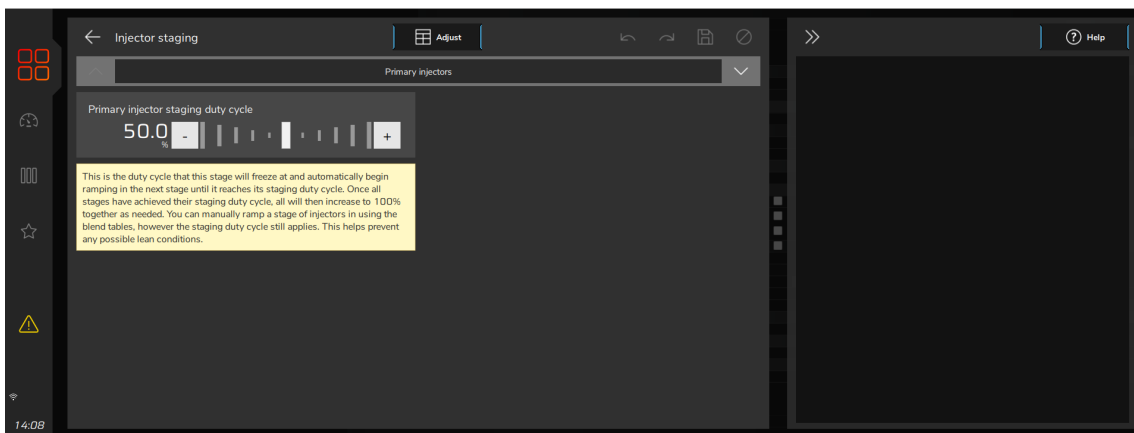

### 18.5 O2 close loop target table

This map allows you to define a AFR value for each RPM x MAP or (TPS). AFR is a measure of the ratio between the amount of air actually present in the air-fuel mixture and the amount of air stoichiometrically required for complete combustion of the fuel.

The standard RPM range is every 200 rpm up to 3000 rpm, above this RPM range the range is defined every 500 rpm up to maximum engine RPM. The turbo vacuum and pressure ranges, throttle opening (TPS) and RPM can be modified via desktop software or directly in the VCU in a table with a resolution of (32x32) points, allowing more precise adjustment of a specific region of the map.

To add or remove columns or rows, right-click (desktop) or long-click (VCU screen) on the column or row to edit it. You can also invert axes and switch to other scales by pressing the top left corner of the table (1).

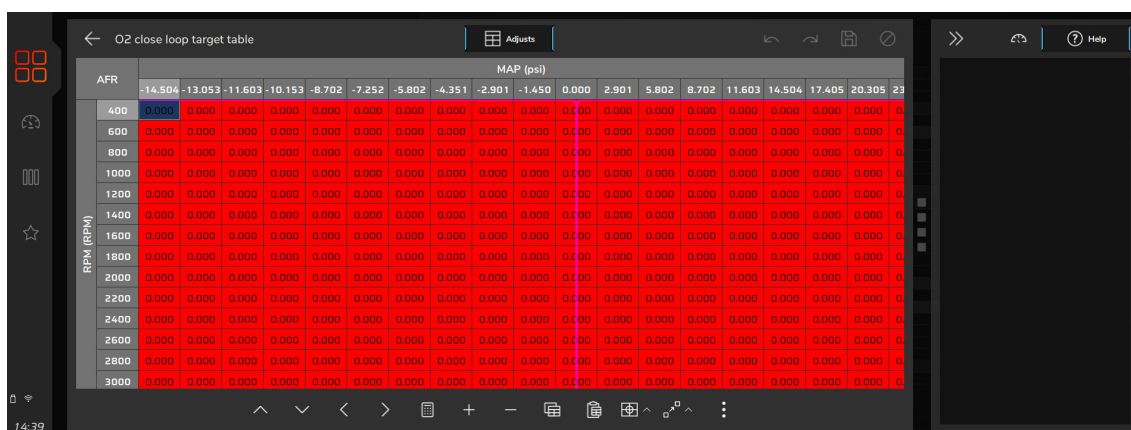

		MAP (psi)																			
AFR		-14.504	-13.053	-11.603	-10.153	-8.702	-7.252	-5.802	-4.351	-2.901	-1.450	0.000	2.901	5.802	8.702	11.603	14.504	17.405	20.305	23	
RPM (RPM)	400	0.000	0.000	0.000	0.000	0.000	0.000	0.000	0.000	0.000	0.000	0.000	0.000	0.000	0.000	0.000	0.000	0.000	0.000	0	
	600	0.000	0.000	0.000	0.000	0.000	0.000	0.000	0.000	0.000	0.000	0.000	0.000	0.000	0.000	0.000	0.000	0.000	0.000	0.000	0
	800	0.000	0.000	0.000	0.000	0.000	0.000	0.000	0.000	0.000	0.000	0.000	0.000	0.000	0.000	0.000	0.000	0.000	0.000	0.000	0
	1000	0.000	0.000	0.000	0.000	0.000	0.000	0.000	0.000	0.000	0.000	0.000	0.000	0.000	0.000	0.000	0.000	0.000	0.000	0.000	0
	1200	0.000	0.000	0.000	0.000	0.000	0.000	0.000	0.000	0.000	0.000	0.000	0.000	0.000	0.000	0.000	0.000	0.000	0.000	0.000	0
	1400	0.000	0.000	0.000	0.000	0.000	0.000	0.000	0.000	0.000	0.000	0.000	0.000	0.000	0.000	0.000	0.000	0.000	0.000	0.000	0
	1600	0.000	0.000	0.000	0.000	0.000	0.000	0.000	0.000	0.000	0.000	0.000	0.000	0.000	0.000	0.000	0.000	0.000	0.000	0.000	0
	1800	0.000	0.000	0.000	0.000	0.000	0.000	0.000	0.000	0.000	0.000	0.000	0.000	0.000	0.000	0.000	0.000	0.000	0.000	0.000	0
	2000	0.000	0.000	0.000	0.000	0.000	0.000	0.000	0.000	0.000	0.000	0.000	0.000	0.000	0.000	0.000	0.000	0.000	0.000	0.000	0
	2200	0.000	0.000	0.000	0.000	0.000	0.000	0.000	0.000	0.000	0.000	0.000	0.000	0.000	0.000	0.000	0.000	0.000	0.000	0.000	0
	2400	0.000	0.000	0.000	0.000	0.000	0.000	0.000	0.000	0.000	0.000	0.000	0.000	0.000	0.000	0.000	0.000	0.000	0.000	0.000	0
	2600	0.000	0.000	0.000	0.000	0.000	0.000	0.000	0.000	0.000	0.000	0.000	0.000	0.000	0.000	0.000	0.000	0.000	0.000	0.000	0
	2800	0.000	0.000	0.000	0.000	0.000	0.000	0.000	0.000	0.000	0.000	0.000	0.000	0.000	0.000	0.000	0.000	0.000	0.000	0.000	0
	3000	0.000	0.000	0.000	0.000	0.000	0.000	0.000	0.000	0.000	0.000	0.000	0.000	0.000	0.000	0.000	0.000	0.000	0.000	0.000	0

### 18.6 AFR Target Map

This map allows you to define a lambda value for each RPM x MAP or (TPS). AFR is a measure of the ratio between the amount of air actually present in the air-fuel mixture and the amount of air stoichiometrically required for complete combustion of the fuel.

The standard RPM interval is every 200 rpm up to 3000 rpm, above this RPM range the interval is defined as every 500 rpm up to the maximum engine RPM. The vacuum and turbo pressure, throttle opening (TPS) and RPM intervals can be modified via desktop software or directly in the VCU in a table with a resolution of (32x32) points, allowing you to adjust a specific region of the map more precisely.

To add or remove columns or rows, right-click (desktop) or long-click (VCU screen) on the column or row to edit it. You can also invert axes and switch to other scales by pressing the upper left corner of the table (1).

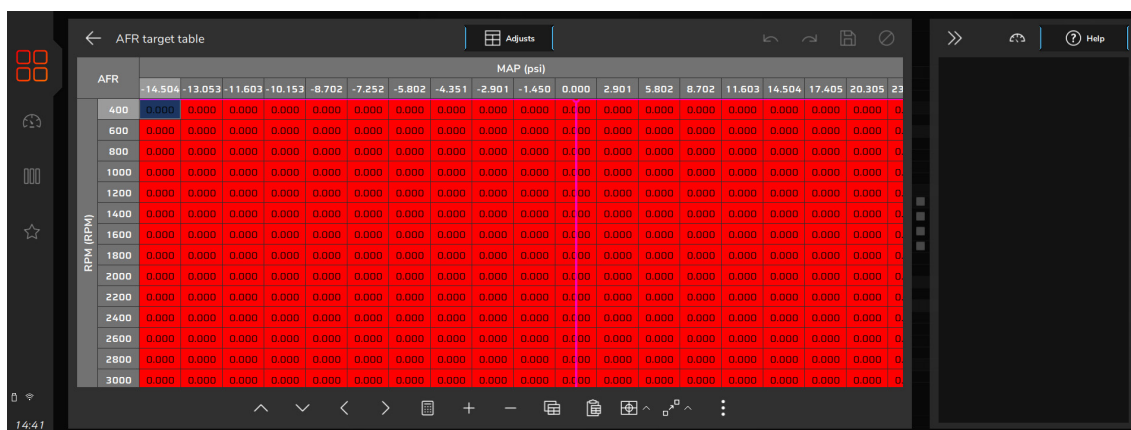

		MAP (psi)																			
AFR		-14.504	-13.053	-11.603	-10.153	-8.702	-7.252	-5.802	-4.351	-2.901	-1.450	0.000	2.901	5.802	8.702	11.603	14.504	17.405	20.305	23	
RPM (RPM)	400	0.000	0.000	0.000	0.000	0.000	0.000	0.000	0.000	0.000	0.000	0.000	0.000	0.000	0.000	0.000	0.000	0.000	0.000	0	
	600	0.000	0.000	0.000	0.000	0.000	0.000	0.000	0.000	0.000	0.000	0.000	0.000	0.000	0.000	0.000	0.000	0.000	0.000	0.000	0
	800	0.000	0.000	0.000	0.000	0.000	0.000	0.000	0.000	0.000	0.000	0.000	0.000	0.000	0.000	0.000	0.000	0.000	0.000	0.000	0
	1000	0.000	0.000	0.000	0.000	0.000	0.000	0.000	0.000	0.000	0.000	0.000	0.000	0.000	0.000	0.000	0.000	0.000	0.000	0.000	0
	1200	0.000	0.000	0.000	0.000	0.000	0.000	0.000	0.000	0.000	0.000	0.000	0.000	0.000	0.000	0.000	0.000	0.000	0.000	0.000	0
	1400	0.000	0.000	0.000	0.000	0.000	0.000	0.000	0.000	0.000	0.000	0.000	0.000	0.000	0.000	0.000	0.000	0.000	0.000	0.000	0
	1600	0.000	0.000	0.000	0.000	0.000	0.000	0.000	0.000	0.000	0.000	0.000	0.000	0.000	0.000	0.000	0.000	0.000	0.000	0.000	0
	1800	0.000	0.000	0.000	0.000	0.000	0.000	0.000	0.000	0.000	0.000	0.000	0.000	0.000	0.000	0.000	0.000	0.000	0.000	0.000	0
	2000	0.000	0.000	0.000	0.000	0.000	0.000	0.000	0.000	0.000	0.000	0.000	0.000	0.000	0.000	0.000	0.000	0.000	0.000	0.000	0
	2200	0.000	0.000	0.000	0.000	0.000	0.000	0.000	0.000	0.000	0.000	0.000	0.000	0.000	0.000	0.000	0.000	0.000	0.000	0.000	0
	2400	0.000	0.000	0.000	0.000	0.000	0.000	0.000	0.000	0.000	0.000	0.000	0.000	0.000	0.000	0.000	0.000	0.000	0.000	0.000	0
	2600	0.000	0.000	0.000	0.000	0.000	0.000	0.000	0.000	0.000	0.000	0.000	0.000	0.000	0.000	0.000	0.000	0.000	0.000	0.000	0
	2800	0.000	0.000	0.000	0.000	0.000	0.000	0.000	0.000	0.000	0.000	0.000	0.000	0.000	0.000	0.000	0.000	0.000	0.000	0.000	0
	3000	0.000	0.000	0.000	0.000	0.000	0.000	0.000	0.000	0.000	0.000	0.000	0.000	0.000	0.000	0.000	0.000	0.000	0.000	0.000	0

## 18.7 Main fuel table

The main injection map is a 3D table, where the injection time is adjusted according to the vacuum/turbo pressure reading (or throttle opening - TPS), in relation to the engine speed. The default reading interval is -1.00bar up to the desired pressure range, when configured by TPS the interval will be defined at every 10% of throttle opening. With an injection time resolution of 0.001 milliseconds.

The standard speed range is every 200rpm up to 3000rpm, above this speed range the range is set every 500rpm up to the maximum engine speed. The intervals of vacuum and turbo pressure, throttle opening (TPS) and rotation can be modified via desktop software or directly on the VCU in a table with a resolution of (32x32) points, making it possible to more precisely adjust a specific region of the map.

To add or remove columns or rows click with the right mouse button (desktop) or a long click (VCU screen) on the column or row to edit it is also possible to invert axes and switch to other scales by pressing in the upper corner left of the table (1).

The FT700 has three injection tables A, B, C and the configuration method is the same for all maps.

### NOTES

*Always check the continuity of the data, that is, avoid inconsistent values or those that form graphs with sudden variations. Any feeding to be efficient and correct on this map, must necessarily form a graph of smooth lines.*



Main MAP fuel injection table - Primary		MAP (bar)																					
ms		-1.000	-0.900	-0.800	-0.700	-0.600	-0.500	-0.400	-0.300	-0.200	-0.100	0.000	0.200	0.400	0.600	0.800	1.000	1.200	1.400	1.600	1.800	2.000	2.200
400	0.975	0.975	0.975	0.975	0.975	1.037	1.098	1.160	1.221	1.283	1.344	1.467	1.591	1.714	1.837	1.960	2.083	2.206	2.329	2.452	2.575	2.699	
600	0.975	0.975	0.975	0.975	0.975	1.037	1.098	1.160	1.221	1.283	1.344	1.467	1.591	1.714	1.837	1.960	2.083	2.206	2.329	2.452	2.575	2.699	
800	0.975	0.975	0.975	0.975	0.975	1.037	1.098	1.160	1.221	1.283	1.344	1.467	1.591	1.714	1.837	1.960	2.083	2.206	2.329	2.452	2.575	2.699	
1000	0.975	0.975	0.975	0.975	0.975	1.037	1.098	1.160	1.221	1.283	1.344	1.467	1.591	1.714	1.837	1.960	2.083	2.206	2.329	2.452	2.575	2.699	
1200	0.975	0.975	0.975	0.975	0.975	1.037	1.098	1.160	1.221	1.283	1.344	1.467	1.591	1.714	1.837	1.960	2.083	2.206	2.329	2.452	2.575	2.699	
1400	0.975	0.975	0.975	0.975	0.975	1.037	1.098	1.160	1.221	1.283	1.344	1.467	1.591	1.714	1.837	1.960	2.083	2.206	2.329	2.452	2.575	2.699	
1600	0.975	0.975	0.975	0.975	0.975	1.037	1.098	1.160	1.221	1.283	1.344	1.467	1.591	1.714	1.837	1.960	2.083	2.206	2.329	2.452	2.575	2.699	
1800	0.975	0.975	0.975	0.975	0.975	1.037	1.098	1.160	1.221	1.283	1.344	1.467	1.591	1.714	1.837	1.960	2.083	2.206	2.329	2.452	2.575	2.699	
2000	0.975	0.975	0.975	0.975	0.975	1.037	1.098	1.160	1.221	1.283	1.344	1.467	1.591	1.714	1.837	1.960	2.083	2.206	2.329	2.452	2.575	2.699	
2200	0.975	0.975	0.975	0.975	0.975	1.037	1.098	1.160	1.221	1.283	1.344	1.467	1.591	1.714	1.837	1.960	2.083	2.206	2.329	2.452	2.575	2.699	
2400	0.975	0.975	0.975	0.975	0.975	1.037	1.099	1.162	1.223	1.286	1.347	1.472	1.597	1.721	1.845	1.970	2.094	2.218	2.342	2.467	2.591	2.716	
2600	0.975	0.975	0.975	0.975	0.975	1.038	1.100	1.163	1.225	1.289	1.351	1.476	1.603	1.728	1.854	1.979	2.105	2.230	2.356	2.481	2.607	2.733	
2800	0.974	0.974	0.974	0.974	0.974	1.038	1.101	1.165	1.228	1.291	1.354	1.481	1.609	1.735	1.862	1.989	2.115	2.242	2.369	2.496	2.622	2.750	
3000	0.974	0.974	0.974	0.974	0.974	1.038	1.102	1.166	1.230	1.294	1.358	1.486	1.615	1.743	1.870	1.998	2.126	2.254	2.382	2.510	2.638	2.767	

### 18.8 Overall fuel trim

This function adds or removes fuel from the entire map. When two independent banks are used, this compensation is done individually by bank.

This compensation is a percentage applied over the injection time, not over the injector duty cycle.

This compensation applies a multiplication in the previous values of the map, for example, if at 1.0bar of pressure (in the example of a turbo engine) it was previously injecting 2,000ms equivalent to let's say 50% of the opening of the injector at maximum rotation and a compensation of +10%, this point in the table will pass to 2,200ms and 55% of the injector opening and not 60%.

In all the applied corrections, the injector dead time (deadtime) is considered in order to have a compensation referring to the actually injected fuel and not the injector opening signal.

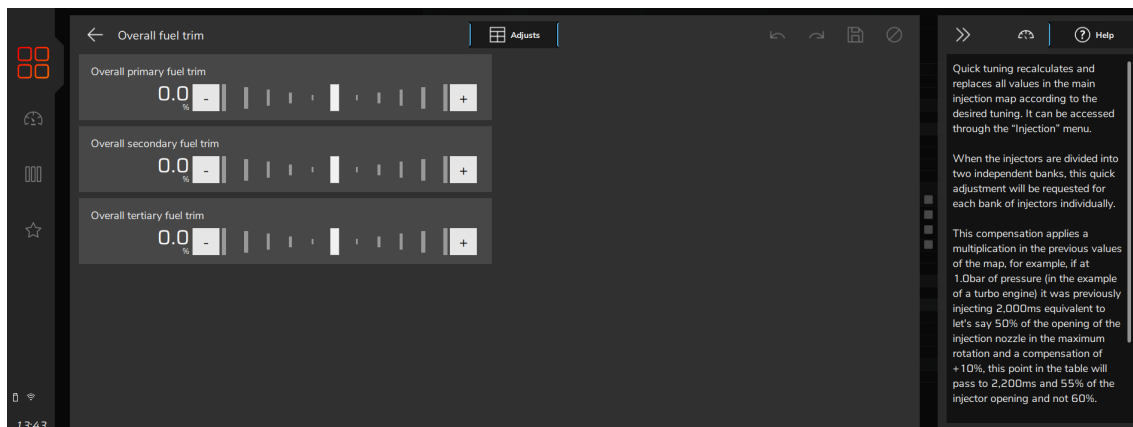

### 18.9 RPM compensation

This option is exclusive to the basic mode. The RPM compensation is a percentage compensation applied to the main fuel table. The calculation is automatically done considering the engine RPM and all the other compensations. This way, a 3D table is not necessary, which despite being more accurate, is harder then the basic mode and very often doesn't show a better result.

With the RPM compensation is possible to have a good tune in any engine type, either a stock engine, race engine or with a variable camshaft (Honda VTEC, Toyota VVT-i, BMW Vanos, etc).

Every engine has a specific fuel consumption peak around the maximum torque rpm, so in the region additive compensation between 5 and 15% must be applied. In a stock engine the maximum torque is normally between 2000rpm and 4500rpm, but to know exactly the rpm a dynamometer is required. Anyway, this compensation will be performed, because, to keep a constant AFR, more fuel will be needed at the maximum torque rpm.

With the main fuel table and the RPM compensation, the ECU generates internally a injection time vs load vs RPM table.

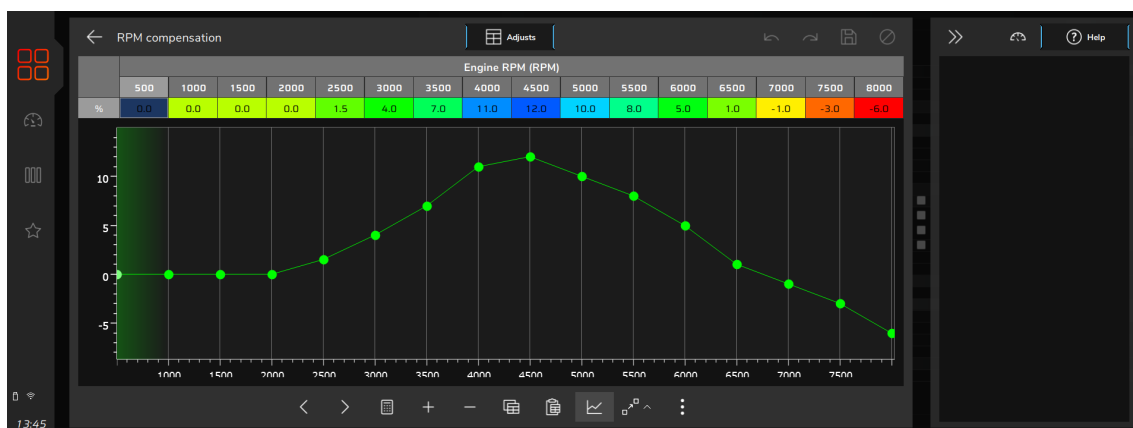

## 18.10 O2 Closed Loop

The closed loop seeks to correct (within the limits established in the control) the fuel injection of the main map, in order to reach the lambda target defined in the target table according to engine speed (RPM) with throttle position (TPS) or engine speed engine with manifold absolute pressure (MAP).

### IMPORTANT

*The closed loop only acts on the injection values of the main map, disregarding the compensations that are applied later (engine temperature, air temperature, nitro, pro-nitro, etc...)*

To enable or disable closed loop, right-click (Desktop) or long-click (on VCU screen) to enable the function. Settings are saved even after disabling the control.

For engines with bank A, bank B and bank C fuel, the closed loop works applying the same correction in the three maps.

**Low load deactivation:** in situations where engine load is too low, closed loop is deactivated (target becomes 0.000). This happens because the injection time in these conditions is very close to the injector's deadtime, making the closed-loop control imprecise.

*Closed loop deactivation:* MAP < -0.20bar and RPM > 2000RPM and TPS < 0.5%

*Closed loop reactivation:* MAP > -0.20bar or RPM < 1800RPM and TPS = 0% TPS > 0.5%

## Settings

**Minimum temperature:** It is the minimum value of the motor temperature for the Lambda control to be activated by the closed loop.

**Smoothing for low load:** It is the control actuation speed for situations of low load, or low or constant speed, this function aims to reduce the control speed for those situations where it does not require such a fast actuation, in order to stabilize the lambda. The higher this value, the more "smoothed" the control will be, that is, slower.

**Block control above/below:** Seeks to turn off the closed loop at pre-established speeds. Used for cases where the probe is very close to the end of the exhaust at low speeds, and at high speeds when the user does not want the system to act on the map after a certain speed.

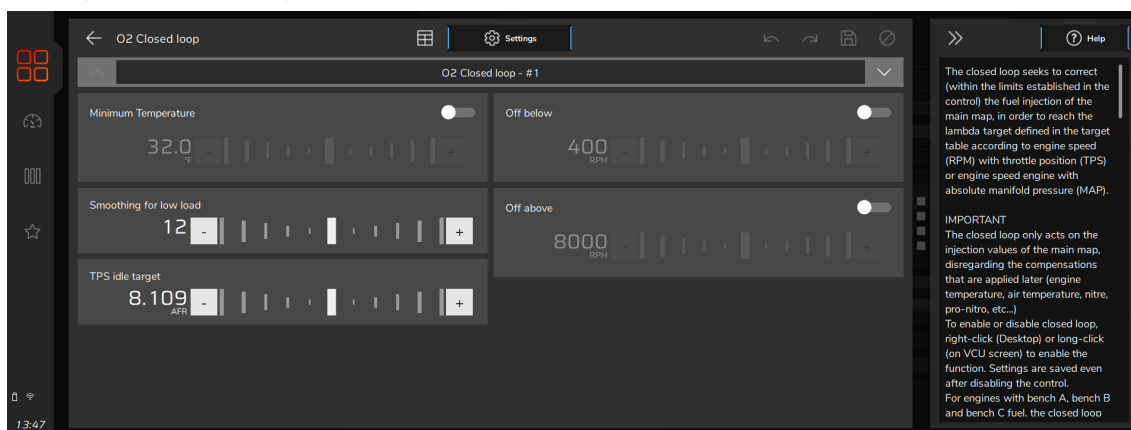

**Behavior during acceleration fuel enrichment:** during fuel enrichment, the closed loop can be turned off or have its target values freeze for a configurable time, keeping the function working. The return to the closed-loop map occurs between 0 and 999ms after the fuel enrichment.

**Average value protection:** This option is a security feature for lambda O2-sensor reading. When the protection is activated, if the O2-sensor reading displays values above: 1.10 lambda / 16.1 AFR gas / 7.0 AFR met, the value will be excluded from the calculation of the average of the closed loop control, in order to prevent errors in closed-loop control due to a lambda sensor problem.

**Activated by target map:** The target will be the same regardless of pressure or rotation.

**Activated with single value:** Uses the same target map table configured for the control.

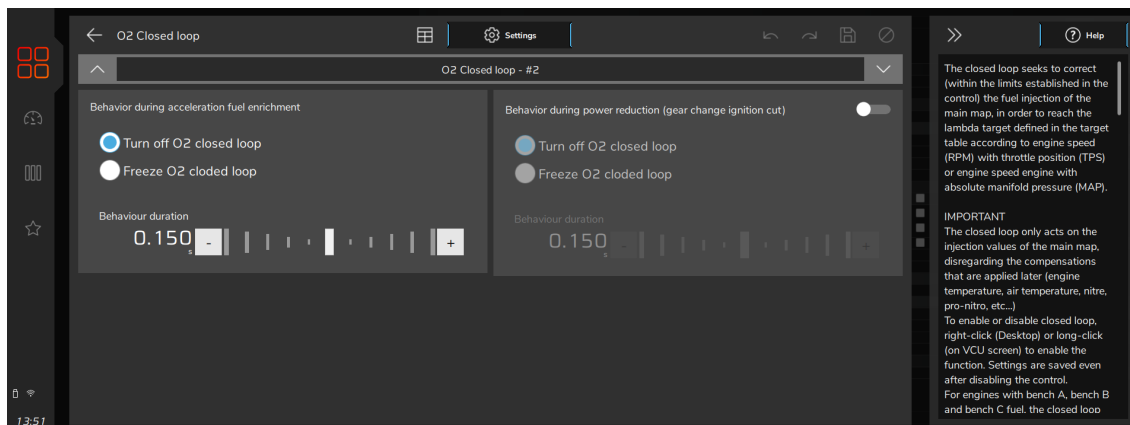

**Behavior during power reduction (gear change ignition cut):** option to turn off or freeze closed loop during ignition and fuel cut on power reduction. Under these conditions the lambda reading is not accurate, so O2 closed loop action can be inappropriate, avoiding this way to increase or decrease injection time in the following moments of the power reduction.

**Closed loop during Anti-lag / Pop&Bangs / Engine brake:** activates closed loop during pop&bangs or anti lag anti lag condition, set the control mode whether by target map or by a single value.

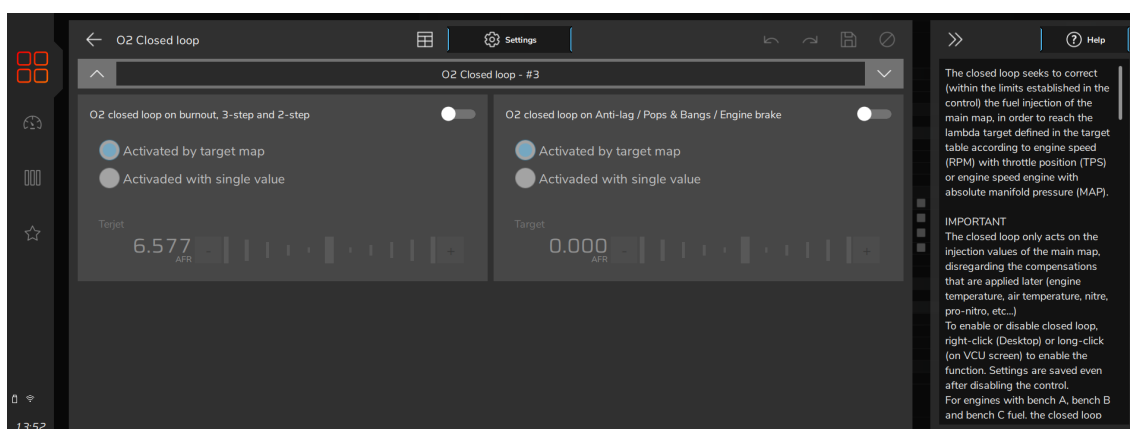

## Aux target table

**Time based:** This feature allows the creation of a 16 points time based O2 target table after the 2-step deactivation, which will overwrite the main O2 target table during the time setup on this auxiliary table. To trigger the 2-step, TPS must be above 50% or RPM must hit the 2-step rev limiter.

**RPM based Pro-Nitrous:** This feature allows the creation of a 16 points RPM based O2 target table to each Pro-Nitrous stage, which will overwrite the main O2 target table while the auxiliary control is on. This feature is only enabled when all Pro-Nitrous requirements are fulfilled.

**Timebased Pro-Nitrous:** This feature is a 16 point time based O2 target table to each Pro-Nitrous stage, which will overwrite the main O2 target table while the auxiliary control is on. This feature is only enabled when all Pro-Nitrous requirements are fulfilled.

**Average value protection:** This is a safety feature for O2 reading. When the protection is enabled, if the reading of one O2 sensor is above 16.1 AFR gas or 7.0 AFR alcohol, the value is excluded of the O2 closed loop control average calculation to prevent a misreading of a damaged sensor.

**Idling target by TPS:** when closed-loop control is active, and the map is by TPS, the closed-loop value for TPS can be set to 0%.

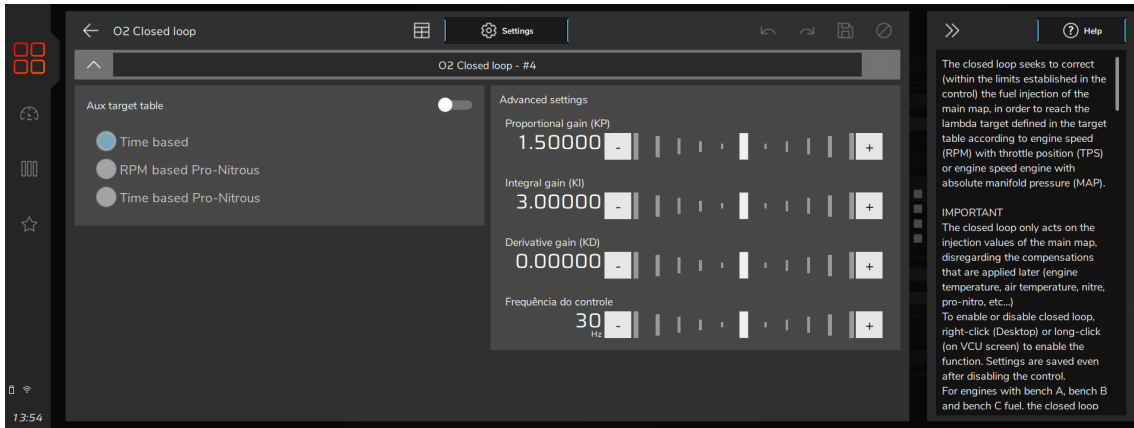

## Settings

**O2 Closed loop target:** This is the lambda target map that the Closed loop control will use as a base to tune your map.

This table has up to 256 points (up to 16 columns and 16 rows ) and relates engine speed (RPM) with throttle position (TPS) or engine speed with manifold absolute pressure (MAP).

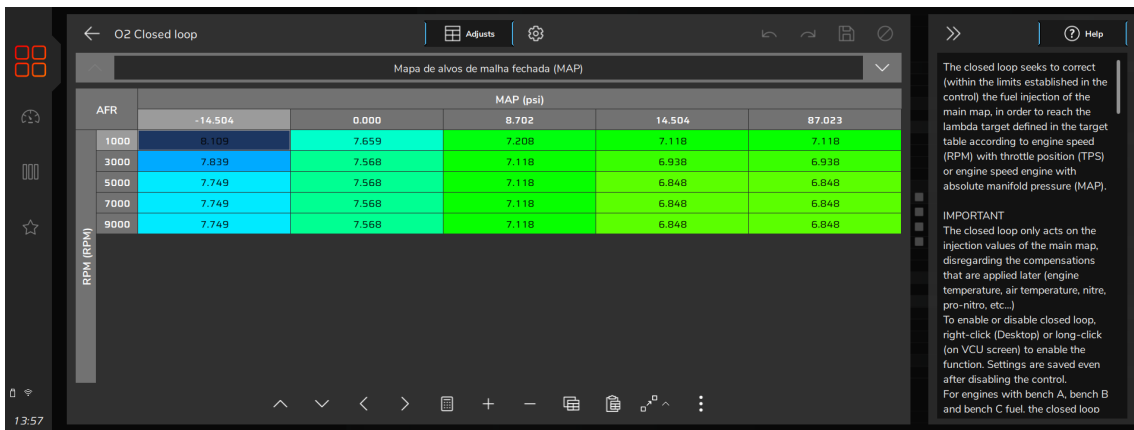

**O2 Closed loop - Limits of control:** Table with up to 16 points (8 columns and 2 rows) that sets the maximum closed loop compensation according to throttle position (TPS ) or manifold absolute pressure (MAP).

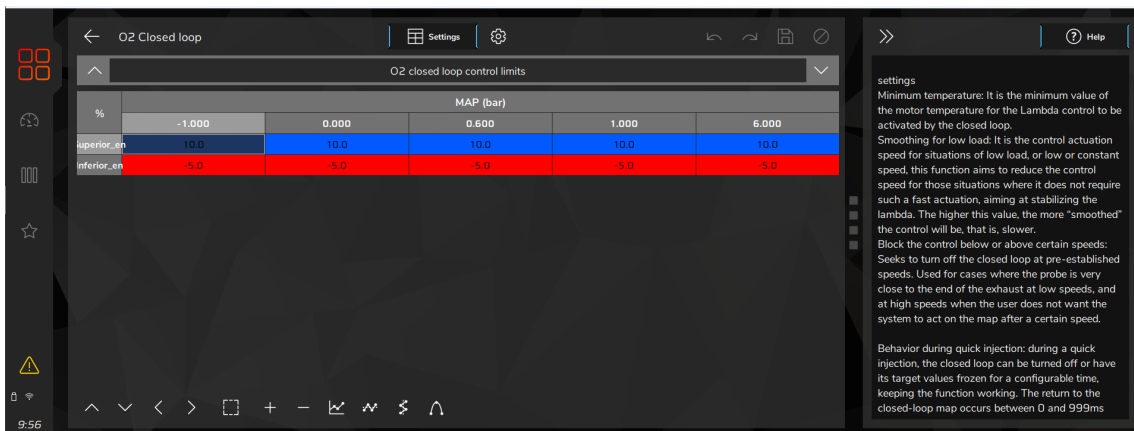

**O2 closed loop – aux by time (2-step):** Allows the use of different O2 closed loop control limits for Aux time table. Set minimum and maximum compensation limits according to time in seconds.



**Aux. Pro-Nitrous by RPM:** The lambda target vs RPM table is used while the Pro-Nitrous is activated. With this feature enabled and Pro-Nitrous activated, the main closed loop table is completely disregarded. It is only used again after the Pro-Nitrous deactivation.

**Aux. Pro-Nitrous by time:** A table with AFR/Lambda targets by time for each Pro-Nitrous stage. The time counter starts when a stage is activated and lasts the time set in the time column.

With this feature and the Pro-Nitrous enabled, the closed loop feature uses this table as the target while each nitrous stage is active. After the Pro-Nitrous timers are done, the standard closed loop target table is used for reference again.

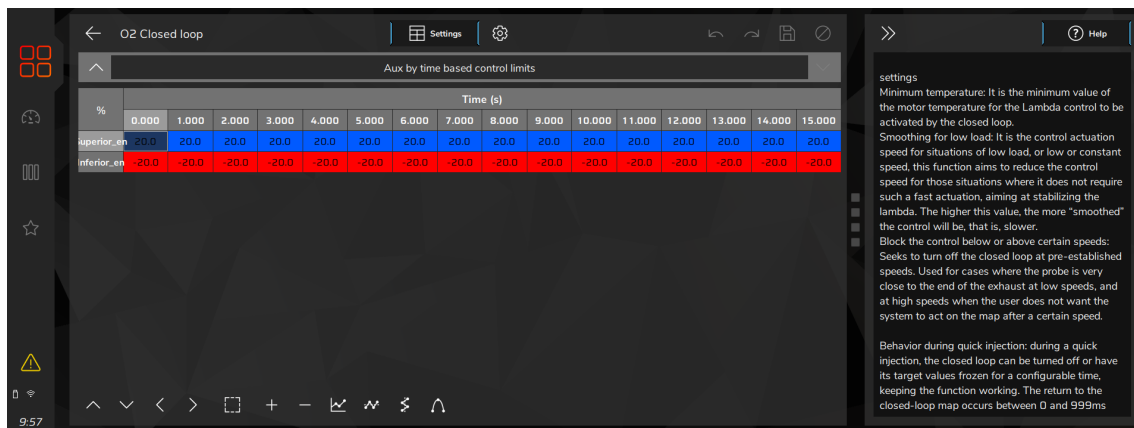

## 18.11 Idle speed by TPS table

This menu is only available when the idle speed is set up by TPS. The injection time is adjusted according to the engine RPM.



## 18.12 Acceleration fuel enrichment and decay

Acceleration enrichment is a fuel increase when the throttle is suddenly opened.

**Max fuel on pump:** value added to the actual injection time when a quick throttle variation is detected. There are two RPM and injection time parameters to be set. With them, the FT creates an acceleration fuel table that interpolates the values between these two positions.

**TPS/MAP variation for maximum fuel pump shot:** This configures the MAP or TPS variation for which the max fuel pump will be used. Engines equipped with small throttles usually need a higher TPS variation to need max fuel pump. In this case, use higher TPS values on this parameter (70-90%). For big diameter throttle bodies, a small TPS variation is enough to demand max fuel pump (around 15%). The TPS or MAP selection is done in the Engine Setup menu. If the TPS is not present, MAP must be selected.

**Accel fuel pump reduction above TPS 50%:** due to reduced need of fuel when the acceleration fuel pump occurs with the throttle already opened above 50%, this parameter reduces the max fuel pump on this condition. By standard, the ECU reduces 50% of the max pump when it occurs above 50% of TPS.

**Cold engine fuel pump enrichment:** this is a simple increase on the max fuel pump value when the engine is cold, especially necessary on the first few minutes of engine operation.

**Fuel decay on max pump:** this is the injection time that will be subtracted from the actual injection time during a sudden throttle closure. With this, in a fast throttle closing, is possible to remove fuel and have a more stable AFR during deceleration.

**Minimum variation of TPS/MAP for pump shot:** A minimum percentage of variation can be set so the pump shot only starts to be applied above it.

**Minimum variation of TPS/MAP for decay:** A minimum percentage of variation can be set so the decay only starts to be applied above it.

**Decay max pulse:** that's the injection time to be subtracted from the actual injection time in the event of a sudden throttle closure

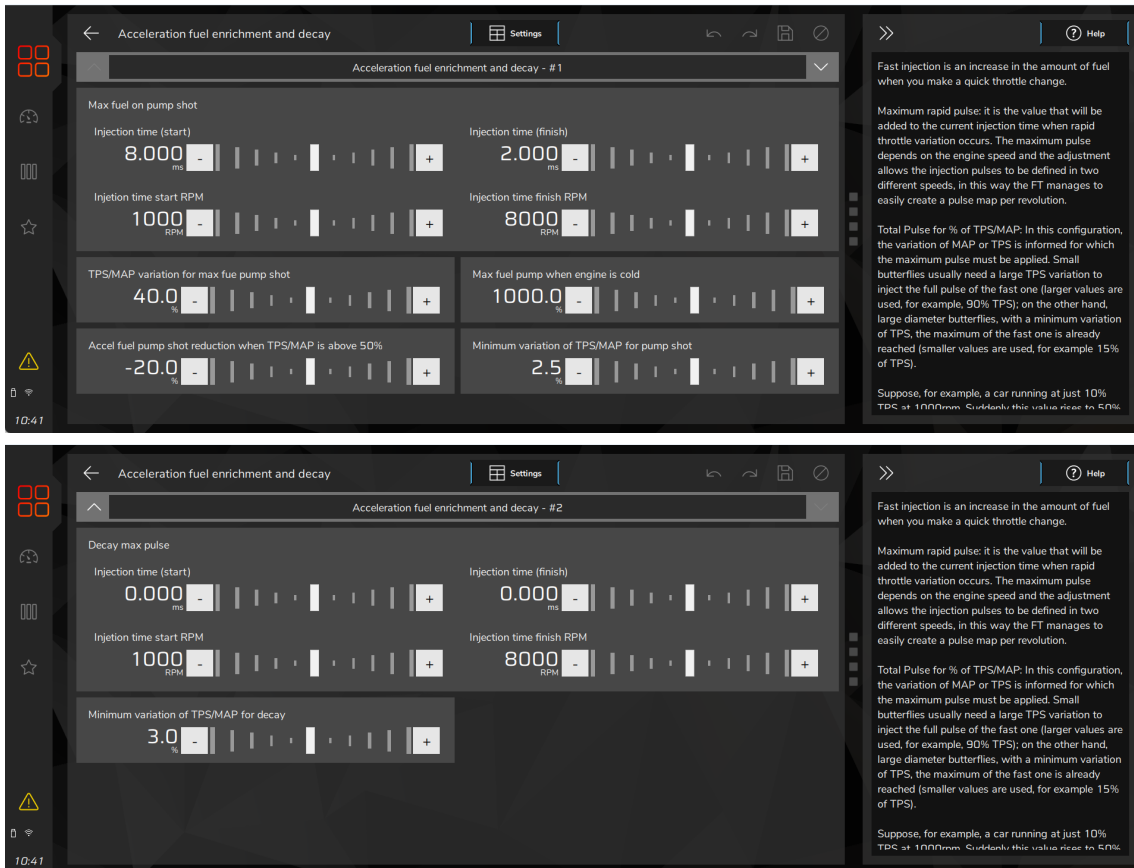

### 18.13 Engine temperature compensation

This compensation is applied based on the engine temperature sensor, which, in water-cooled cars, must be at the cylinder head reading the water temperature, and in air-cooled engines, must be reading the oil temperature.

Compensations based on engine temperature are only available when the sensor is connected to the injection system.

Engine temperature greatly influences the amount of fuel requested by the engine, especially in cars run with ethanol and methanol, when it is possible to operate a cold engine as if it had already reached normal temperatures.



### 18.14 Intake air temperature compensation

This compensation is applied based on the air temperature sensor placed in the intake manifold, and it is only available when the sensor is connected to the injection system.

This compensation mode is used to automatically adapt the injection to different temperatures of the air taken by the engine.

In turbocharged engines, it is of great importance, because when the system is pressurized, the temperature rises immediately to very high numbers.

In cars with intercooler, the ideal mixture can be used from intercooler inefficiency situations (low speed) on.



### 18.15 Battery voltage compensation

This compensation is applied based on the vehicle's battery voltage and it takes into consideration that the decrease in fuel injectors' feed voltage influences their opening time.

It is a subtle compensation, but very useful in cases when there are great voltage variations caused by the lack of an alternator, for example.

Fuel injectors with a high flow rate usually operate with minimum injection time at idle speed and are the ones most affected by a drop of battery voltage, as a variation in their dead time occurs, which may lead to an injection glitch, meaning that the fuel injectors may not work as a result of voltage drop.

By using this compensation, such problem is avoided.



### 18.16 MAP / TPS compensation

This table changes according to the main map configuration (MAP or TPS). When the main fuel table is setup by MAP, this table is a compensation by TPS. When the main fuel table is setup by TPS, this compensation is by MAP.

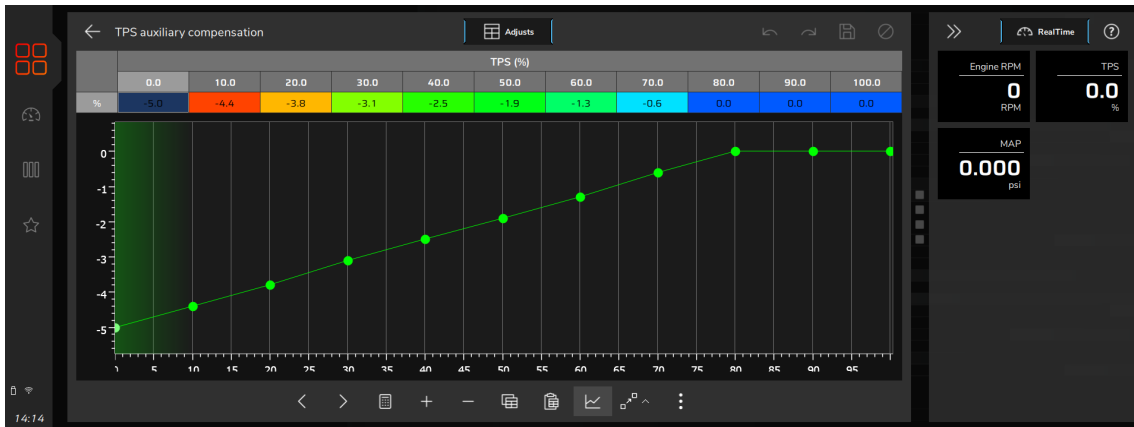

### 18.17 Prime pulse

This feature improves the engine start by injecting fuel when any crank trigger tooth is detected, just like OEM ECUs. Usually this table uses injection times higher than the “engine start” parameter injection times.

Select which fuel bank you want to use for prime pulse and setup its table by engine temperature.

The injection time is related to engine temperature. The colder the engine, the bigger the injection time.



### 18.18 Engine start

This function is essential when starting the engine, as it needs a greater injection pulse to initiate its operation, especially if the vehicle runs on ethanol or methanol.

Whenever the RPM drops below 400rpm, the ECU applies start injection pulses in addition to the idle speed value. This excess of fuel prevents the engine from failing involuntarily, making it return to idle speed. Be careful not to exaggerate on injection time, as it may cause the engine to stall/flood easily.

The engine must always be turned off through the injection system. Otherwise, if RPM drops below 400rpm and injection is turned on, the system injects fuel that will not be burned and, therefore, will be accumulated on the cylinder.

If the engine temperature sensor has not been installed, only the value from start injection with cold engine is considered.

The bank B option will be only available if enabled on "Fuel Injection" menu on "Engine Settings".



### 18.19 Post-start enrichment

This configuration is a table that relates engine temperature with time in seconds. This parameter helps stabilizing engine RPM just after start, improving the idle control especially under low temperature conditions.

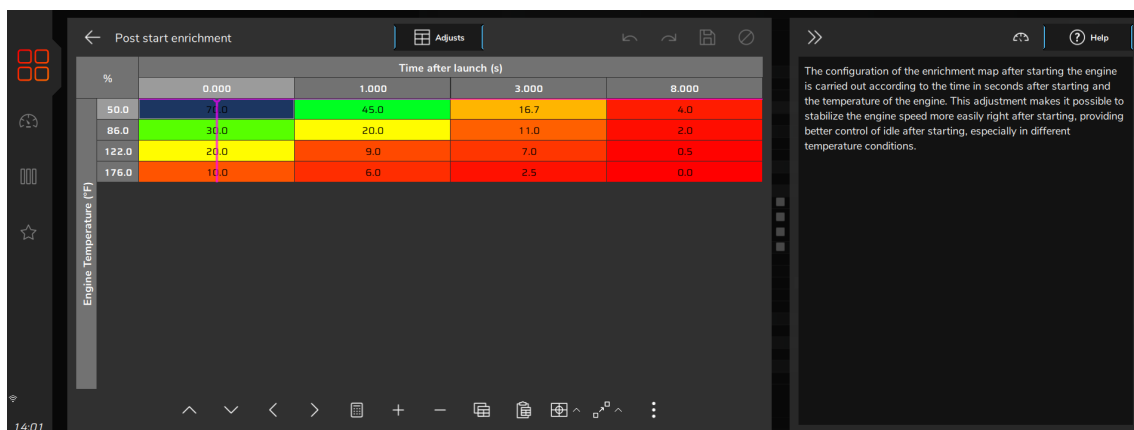

### 18.20 Individual cylinder trim

Set a compensation to each injectors output on a table that relates engine RPM with individual cylinder trim compensation.

To use this compensation as a cylinder trim, the injectors have to be wired with one output per injector.

This compensation usually brings minor power gains when correctly used, so, the use of one O2 sensor per cylinder is highly recommended



### 18.21 Gear compensation

This option enables a fuel enrichment or timing compensation according to the RPM for each gear.

To enable this feature, the gear detection must be already configured through Sensors and Calibration menu. It's possible to set up to 6 compensation tables (one for each gear).

To use this feature is mandatory that gear detection is already setup through Sensors and Calibrations menu.

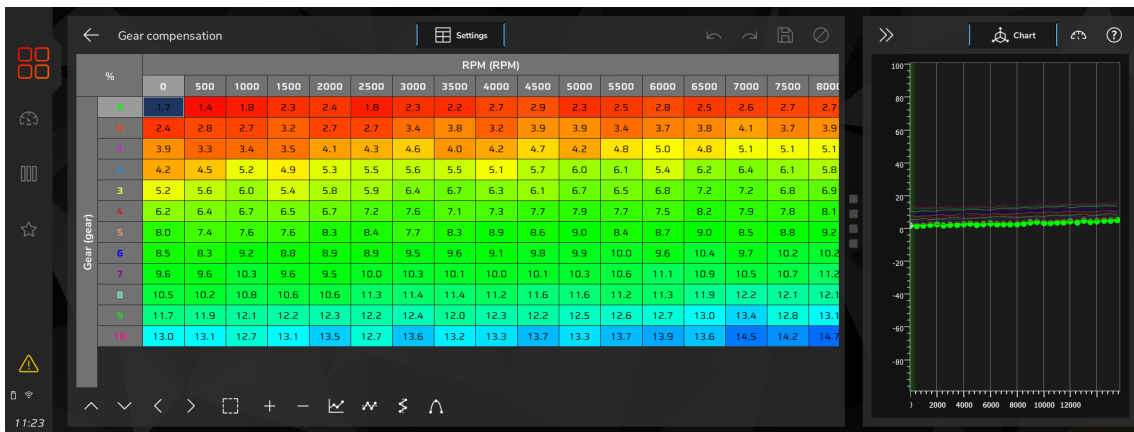

### 18.22 Gear change compensation

Enables a fuel compensation map by time, activated when a gear shift is detected.

A minimum value for TPS can be set up to allow the map to be activated only when a gear shift is detected with TPS above this value. If a gear shift is detected and the TPS is below the minimum value, the map will not be activated.



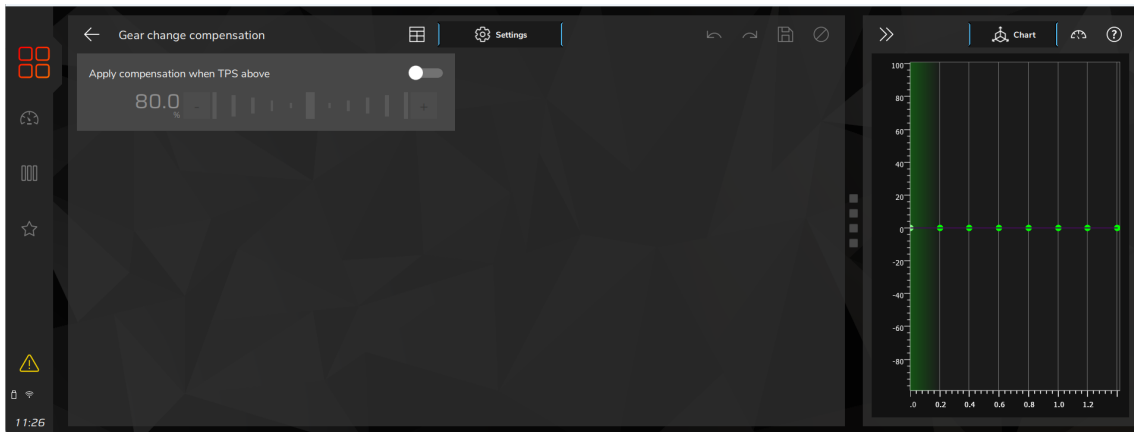

### 18.23 Fuel injection angle table

This table changes the moment, during the engine cycle, where the injectors opens or closes.

To explain what this angle is, think about the ignition timing. When talking about ignition, the timing means the angular distance between the combustion TDC and the moment the spark plug ignites.

The fuel injection angle is the distance, in degrees BTDC from the ignition TDC (0°) until the moment the injector opens or closes (according to what is selected).





# ***IGNITION***

Tables



## 19. Ignition tables adjust

All timing tables can advance or retard timing. When a base map is generated, all tables are filled with standard values, so, if you want to use just the main timing table, you must zero fill all compensations manually.

### 19.1 Main ignition map

The main ignition map is configured in a table format (3D), where the ignition timing is adjusted according to the reading of the vacuum and turbo pressure, in relation to the engine speed. When configured by MAP, the default reading interval is -1.00bar up to the desired pressure range.

The standard speed range is every 200rpm up to 3000rpm, above this speed range the range is set every 500rpm up to the maximum engine speed.

The intervals of vacuum and turbo pressure, throttle opening (TPS) and rotation can be modified via Desktop software in a table with a resolution of (32x32) points, making it possible to more precisely adjust a specific region of the map.

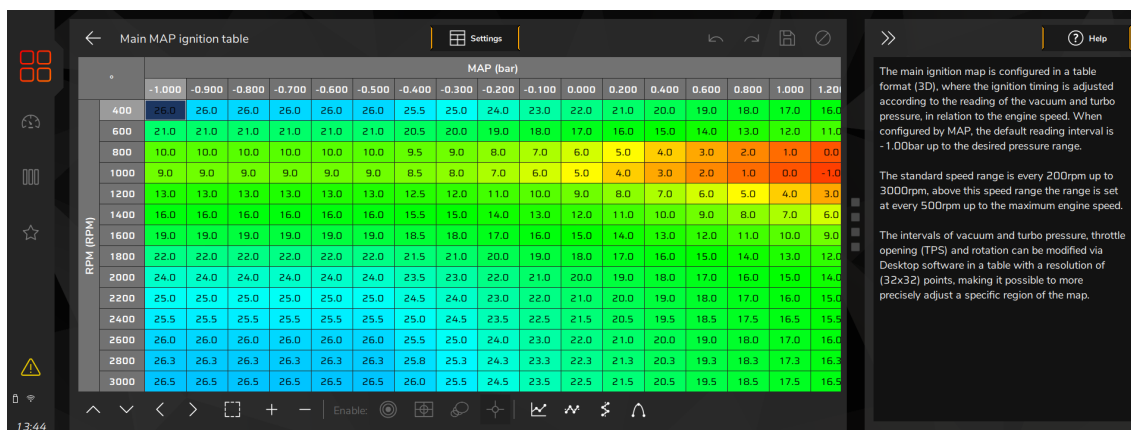

### 19.2 Overall ignition trim

To apply a quick compensation to the entire ignition map, the Overall Ignition Trim function may be used. It is only necessary to inform the correction, negative or positive, and confirm by pressing the right button. This correction will be added to or subtracted from the entire ignition table based on RPM

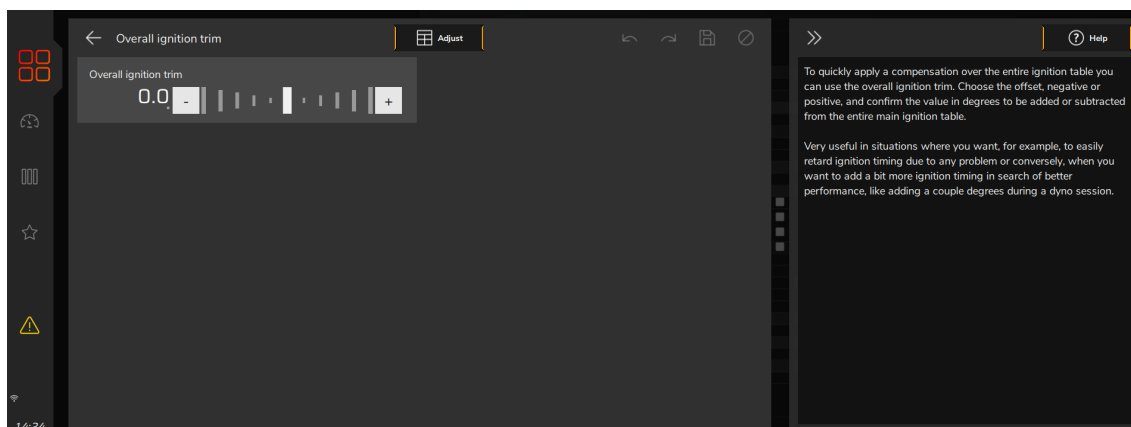

### 19.3 MAP/TPS compensation

This table changes according to the main map configuration (MAP or TPS). When the main ignition table is setup by MAP, this table is a compensation by TPS. When the main ignition table is setup by TPS, this compensation is by MAP.



### 19.4 Intake air temperature compensation

This map represents a timing compensation applied to the main RPM timing map based on intake air temperature variation.

It is beneficial, because the colder the air entering the combustion chamber, the denser it is, and the greater the possible ignition advance is.

But when temperatures are very high (especially on turbocharged engines), the ignition timing must be retarded to protect the engine.



### 19.5 Engine temperature compensation

This map represents a compensation on the advance or retard angle applied to the main RPM map based on engine temperature variation. It is a very important feature and it brings significant improvement on drivability, especially while operating cold engines, when advanced ignition timing is necessary in order to have a correct response from the engine. It is also essential for engine protection, as it retards the ignition timing when the engine reaches high temperatures.



### 19.6 Individual cylinder trim

Set a timing compensation to each ignition output on a table that relates engine RPM with individual cylinder trim compensation. The timing compensation is done individually to each cylinder according to the engine RPM and it comes from the flow differences, heating dissipation capacity or even cylinder position.



### 19.7 Timing limits

This menu is used to configure the maximum and minimum ignition timing limits, so the engine won't run in any situation with too much retard or advanced ignition timing. No other function will be able to apply timing beyond these limits. This is a safety feature to prevent an inappropriate timing, considering all the functions that may enable a timing compensation (mainly drag race time based features).

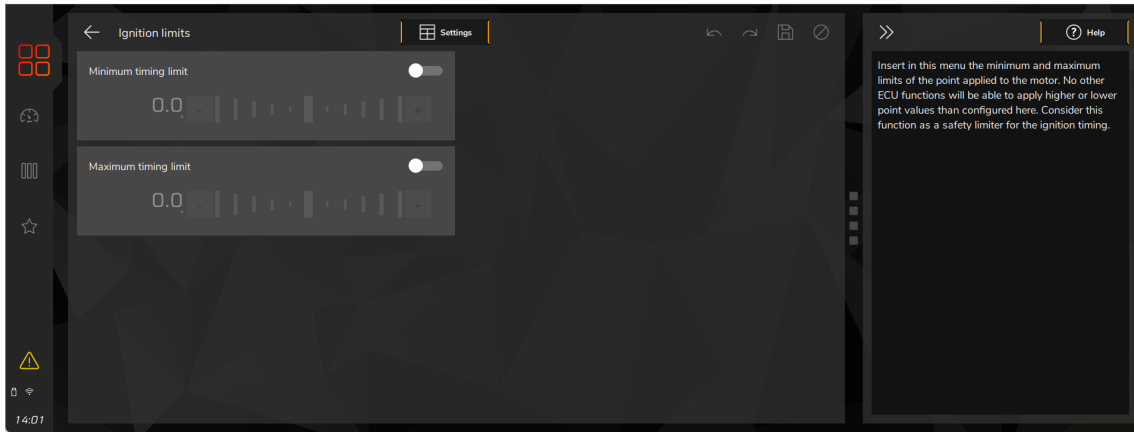

### 19.8 Engine Start

This is an ignition advance vs engine temperature table. Calibrate the ignition advance for each temperature site.

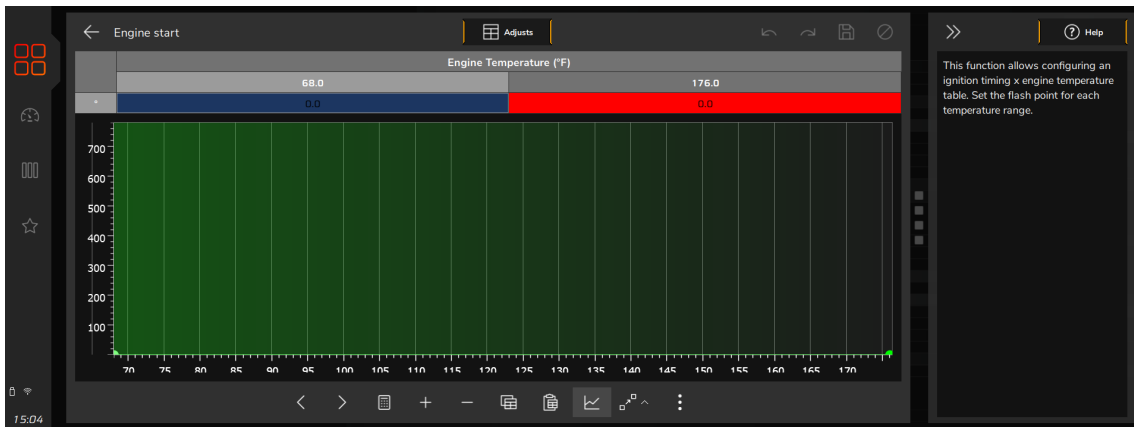

### 19.9 Gear based compensation

This compensation allows advancing or retarding the ignition timing according to the engaged gear. This table applies the compensation in the main ignition table according to engaged gear and RPM.

To enable this option, gear change detection must be enabled. It is possible to set up to 9 compensation tables (10 gears).



### 19.10 Gear shift compensation

This function allows advancing or retarding the timing after a gear shift (upshift).

You can enable a TPS condition so the retard can happen.

In the example, there will be a 5° timing retard. The ramp return time is the retard total time, which will be gradually re-established. In other words, after shift gear, timing will be retarded 5°, 0,25s the retard will be 2.5° and 0,50s after the shift there will be no gear shift compensation.

To enable this option, gear change detection must be enabled. It is possible to set up to 5 compensation tables (6 gears).



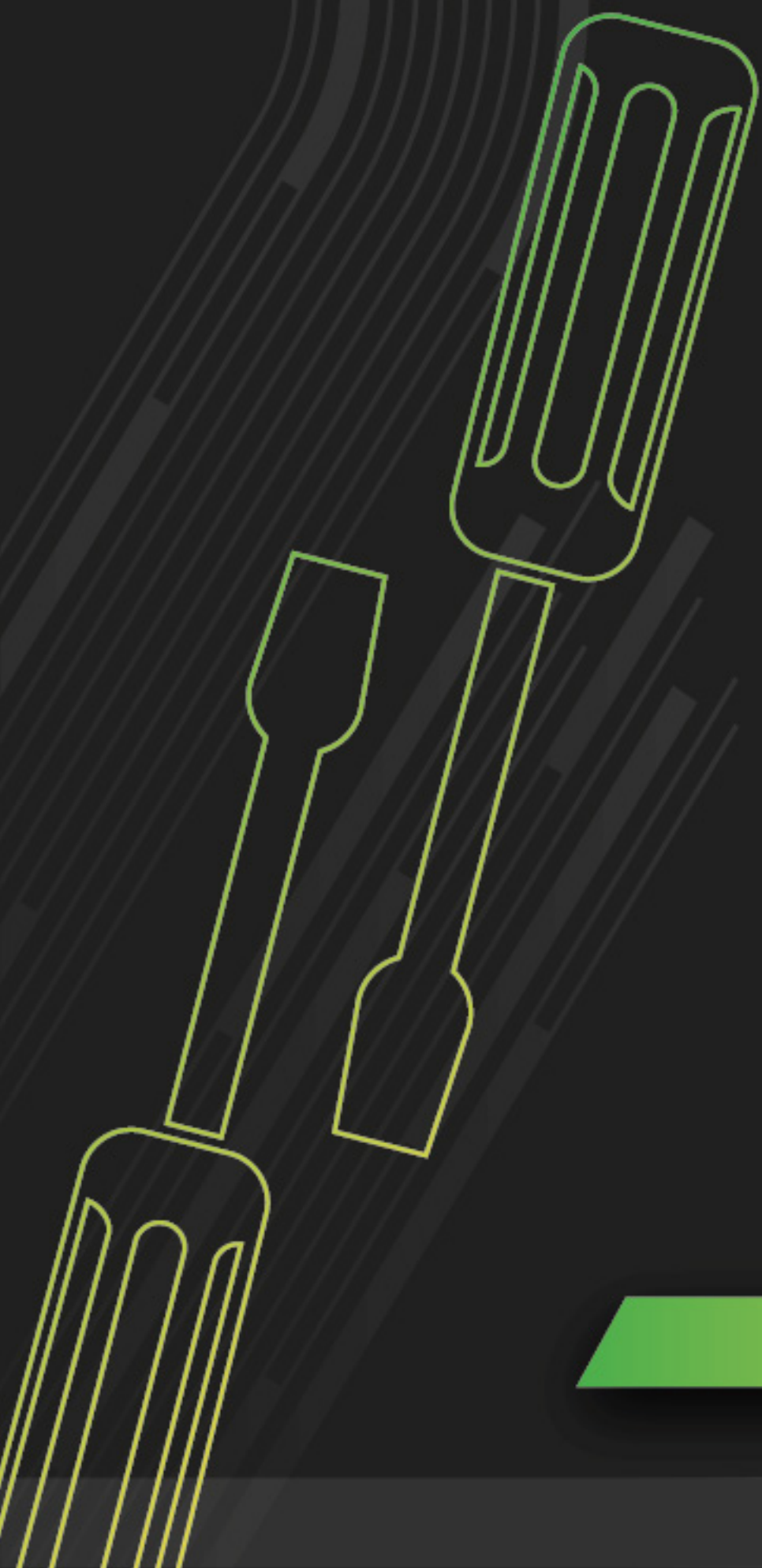

# ***OTHER***

Functions



## 20. Other Functions

This menu contains all the functions that modify the operation of the auxiliary outputs, such as idle speed, timed RPM control, among others. Some of these functions require prior configuration of an auxiliary output to operate correctly.

### 20.1 Idle speed control

This FT can control idle speed through electronic throttle, step motor, PWM valve and by timing.

To enable the idle speed control by electronic throttle, it is needed to setup the menu “*Electronic throttle*” under “*Engine setup*” menu. After that, you can follow this menu to setup idle parameters.

#### Adjusts

**Idle actuator position:** This parameter will be only available when the position on idle is set as fixed. This table relates the actuator position in function of the engine temperature.



**Post-start position:** This parameter will be only available when the position on idle is set as fixed. The table controls the actuator opening after the engine start. The table is an actuator position vs time. After the time slip, the position is defined by the actuator position table based on engine temperature.



**Target idle RPM:** This table tells the ECU the target RPM the idle control will assume, according to engine temperature. On intermediate temperature ranges, target RPM is automatically interpolated. When “Position on idle” is set to “fixed” this table represents the actuator position X engine temperature.



**Post-start position:** This parameter will be only available when the position on idle is set as fixed. The table controls the actuator opening after the engine start. The table is an actuator position vs time. After the time slip, the position is defined by the actuator position table based on engine temperature.



## Settings

**Idle control speed:** shown the speed at which the idle control will allow the engine RPM to drop towards the established target. Very high values can cause the engine to die in reductions, for example. Low values cause a delay in reaching the target RPM to be dropped.

**Idle reaction level:** this parameter is the aggressiveness that the timing and the actuator will be changed of position in order to

Control a RPM fall. The higher this number, the more aggressive is the reaction of the control. High reaction levels may lead the idle speed to be unstable.

**Idle position reference:** this parameter indicates the IAC/electronic throttle position that should be kept when cranking the engine, according to its temperature. It is also used as a stable reference position for the automatic idle control. It is recommended as default for initial startup setting a value of around 4% for electronic throttle and 30% for stepper motor/PWM valve. In general, the value for hot engine is slightly lower than the cold value.

**Position on idle:** adjust mode.

**Automatic:** in this mode, idle actuator is automatically opened and closed by the ECU in order to make the engine idle near the target RPM.

**Fixed:** in this option, idle actuator assumes a fixed position, set up later according to engine temperature.

This option is recommended for engines with high profile camshafts, where the automatic idle control is not able to stabilize idle RPM.

**Idle by timing limits:** this control uses a target RPM for idle speed and works advancing and retarding the engine timing to keep the engine running near the specified RPM. As the ECU idle speed control has an advanced integration with the idle speed by timing control, this one stays always enabled when any other kind of idle speed control is selected.

By doing this, the idle speed actuator is always keep in a position where the idle speed by timing control can set the timing away from the maximum and minimum timing positions. It is essential for the idle speed by timing control that the engine is equipped with a TPS sensor in perfectly working condition as this control only starts when TPS stabilizes on 0%.

**Maximum and minimum timing limits:** these values are the limits for advance and retard when ECU is controlling the idle by timing.

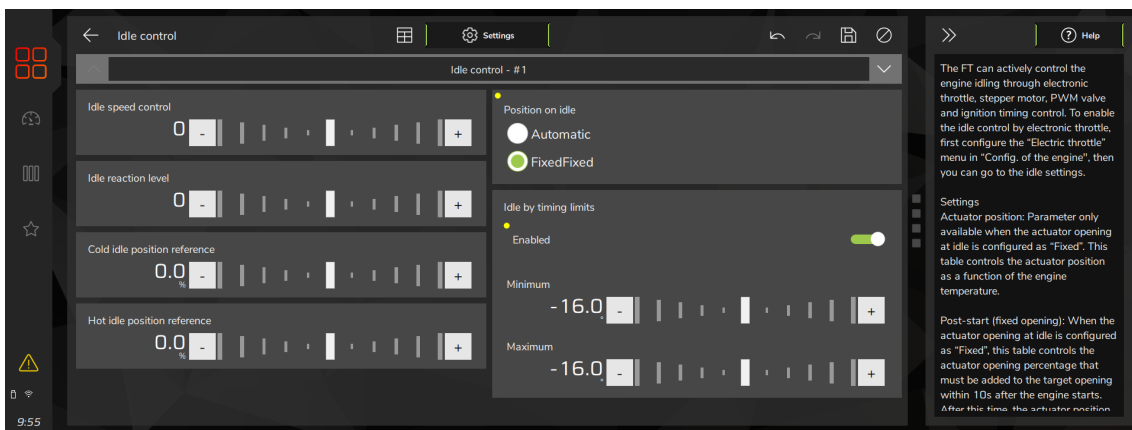

**Enable timing return ramp fr idle by timing:** When enabled, it generates a return ramp for the ignition timing. If this function is disabled, when the idle control is operating the ignition timing will be set as the minimum defined for the condition. When the idle control is off, the ignition timing will return for the value set at the ramp.

**Enable control when the vehicle is moving:** when this option is checked the idle speed control will turn on when the TPS percentage is 0% and the engine RPM is 700 rpm above the set target.

**Compensation by load:** used to compensate actuator position when suddenly loads (like AC or fan) are added to engine and can

Affect idle. It is possible to set an target RPM compensation when the AC is on and fuel/actuator opening compensation for AC and fans.

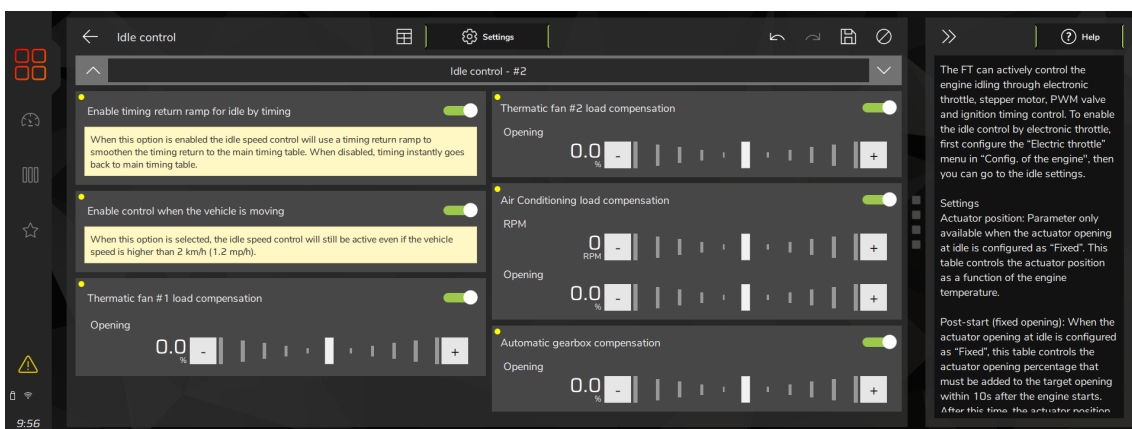

**Timing compensation:** it is used when a load is detected (electric fan or AC). Timing is immediately applied when load is detected, after that the control acts advancing or retarding timing if needed (default 7°).

**Target approach rate:** used to reach RPM target, also responsible for control reaction speed (default 6RPM/s).

**Deadband:** dead zone the control considers as on target. Example: target 800RPM, deadband 50RPM. From 750RPM up to 850rpm the control will be stable (default 50RPM).

**Approach RPM:** added to the target RPM where the control starts to act (this makes the control smoothie). When RPM reaches this number the control uses the target approach until it reaches the RPM target within it's deadband.

**Boundary RPM to enable:** indicates the minimum RPM to the ECU consider Idle, added to the Idle target, for example idle target at 1000RPM, plus 700RPM boundary RPM equals to 1700RPM for idle control strategy.

**Proportional gain (KP):** responsible to identify if the RPM is close or too far from the target, acting according to the number, high numbers can make it instable.

**Integral gain (KI):** responsible for RPM trend, to identify and make changes to reach the target.

**Derivative gain (KD):** evaluates the RPM back in a recent period of time and has been done to be in the actual engine RPM, will provide data to the next sequences of control.

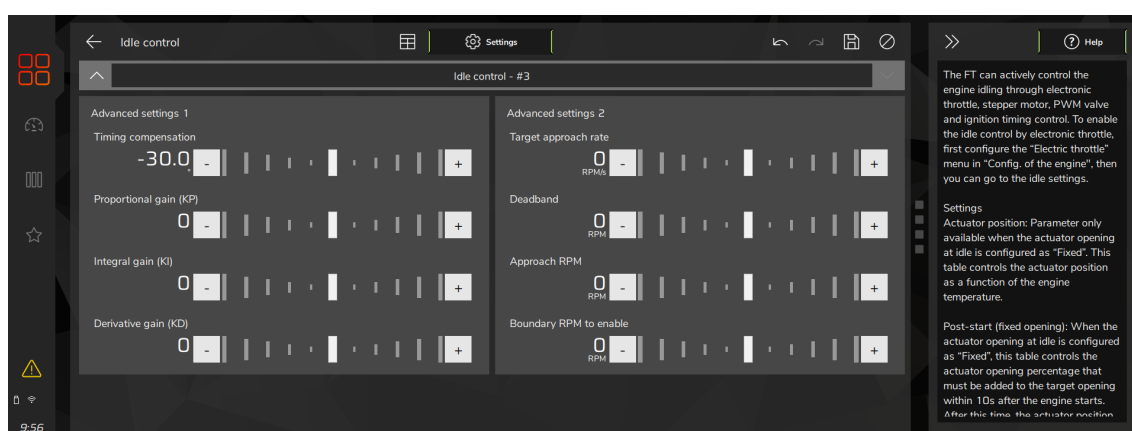

## 20.2 Deceleration cut-off

The purpose of Deceleration cut-off is to improve fuel economy when the engine is at 0% throttle situations.

This aids in the deceleration of the vehicle by making use of engine braking while driving in traffic. This function is valuable to the reduction of fuel consumption. On a circuit racing or auto cross vehicle is utilizing heavy braking going into a turn, it is necessary that it has a quick and clean response from the engine upon re-opening the throttle.

Deceleration cut-off will aid in dynamic braking from the engine as well as overall fuel economy.

A standard RPM of 2000rpm is recommended. Setting a very low RPM may cause the engine to turn off involuntarily during deceleration. The "Cut-off Delay for TPS=0%" parameter is the time (in seconds) delay before fuel is actually cut-off after releasing the throttle. Such delay exists to prevent the engine from instantly becoming lean when the throttle is released. It also rapidly cools the combustion chamber without being excessive, and avoids situations in which the cut-off might oscillate, especially when the throttle is lightly pressed. A standard delay of 0.5s is suggested.

Such delay exists to prevent the engine from instantly becoming lean when the throttle is released.

In order to have the Deceleration cutoff working along with Anti-lag / Pops & Bangs / Engine brake is necessary to enable it according to the following image.

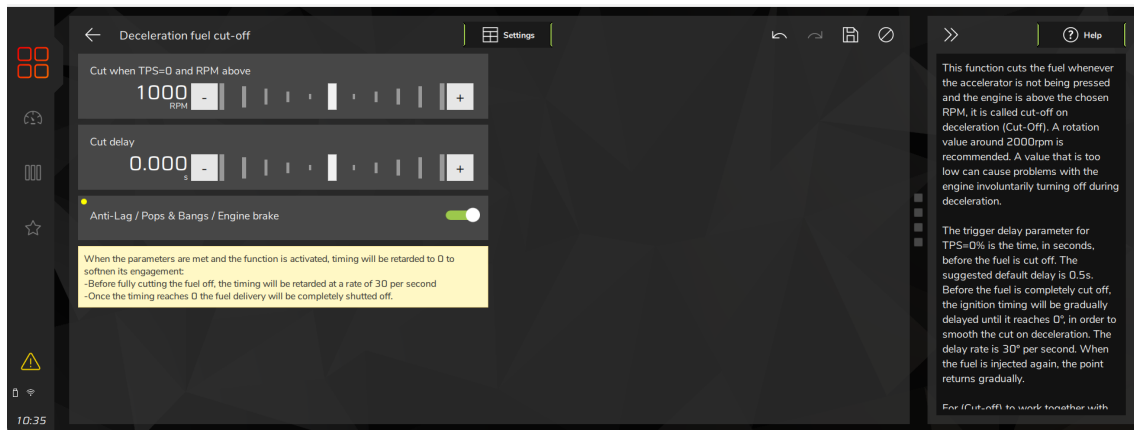

## 20.3 Rev limiter

This function is very important for engine protection, limiting the RPM with two different options of cut:

**Ignition:** the engine ignition is cut-off when the configured RPM is reached. It is recommended for high-power engines, especially turbocharged ones, being the most efficient and safe option.

**Fuel Injection:** the fuel injection is cut-off instantly, as the ignition is still operating. It is a very smooth and clean cut-off. Recommended only for low-power engines, it is the standard setting in vehicles with original injection systems.

**Rev limiter:** There are 3 different options.

**Single value:** Sets a single limit for all engine temperature ranges.

**Engine temperature table:** Set up a table with different RPM values for each temperature range, very useful in periods when the engine is in its warm-up period where the maximum speed limit must be lower to preserve the engine.

**Gear based table:** Table with individual RPM limit values per gear, widely used on road race cars where the rev limit may be different for the high gears, preserving engine and transmission at lower gears.

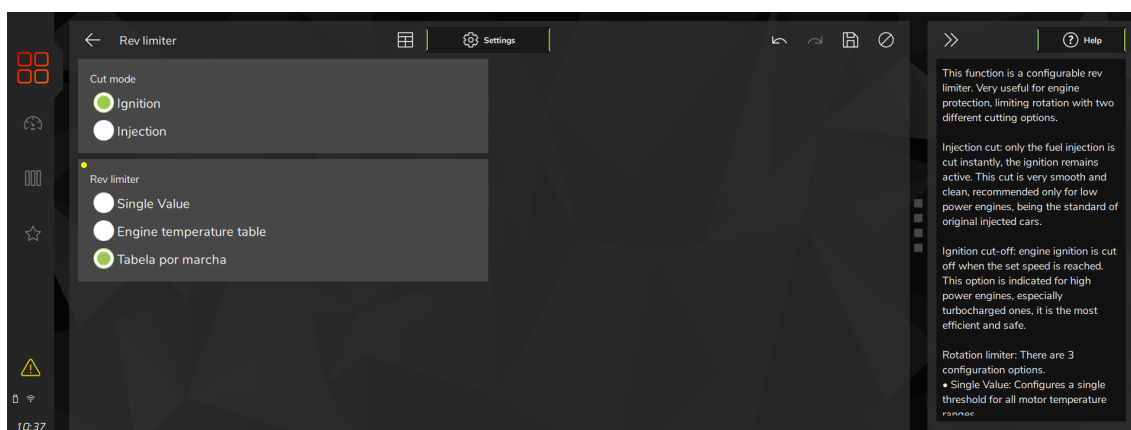

### WARNING

*When the ECU is requested to apply more than one type of ignition cut from different functions simultaneously, the cut with the highest % configured will have priority, so the function with the lowest % of cut might not operate as expected.*

**Gear based rev limiter table:** The use of this function requires that the gear change detection is set correctly, make sure in the menu Sensors and Calibration, Gear change detection.

**Rev limiter by engine temperature:** This table allows a variable final RPM limiter according to the engine temperature. On the table you must setup the desired RPM limiter values according to the engine temperature.

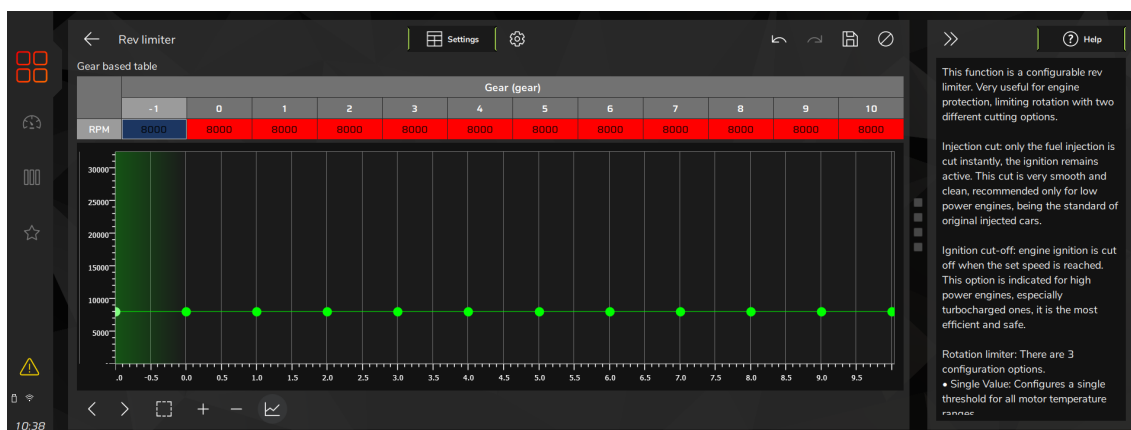

## 20.4 Shift Light

When the engine reaches the RPM set in this parameter, the screen will display a blinking message (“SHIFT”) indicating that gear must be shifted.

To switch a external shift light, it is necessary to configure an auxiliary output at the “Input and Output Setup” menu. If no auxiliary output has been configured as Shift Light, the message “Output not configured!” Will be displayed. Even so, it is possible to set the Shift Light RPM on the screen

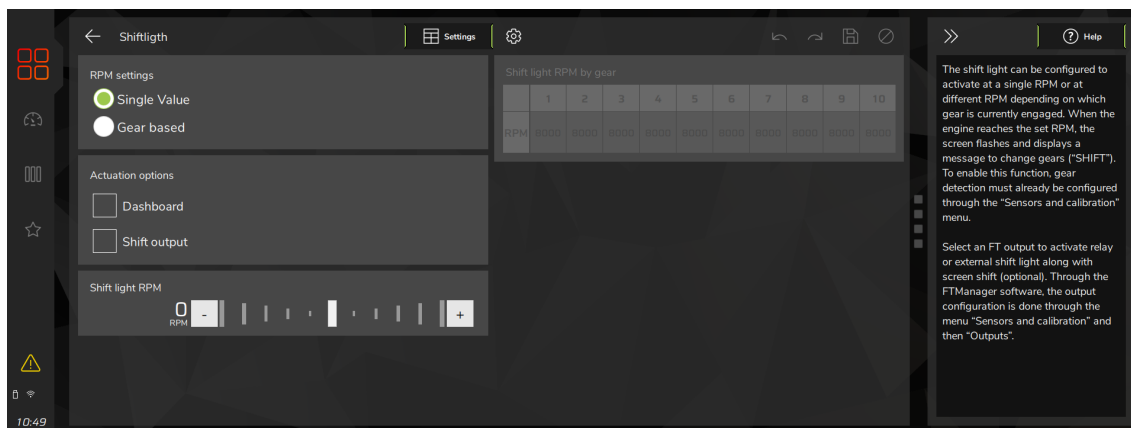

## 20.5 Thematic Fan #1

**Temperature source reference:** Both modes of operation can be set according to the air or engine temperatures.

**Engine temperature:** The most commonly used, the control is made by the temperature in the cooling system.

**Air temperature:** This option may be used for cooling the air of a turbocharged engine equipped with a watercooler or water pump, or even to drag race diesel engine tractors where water is injected inside the combustion chamber for cooling.

**Operation mode:** There are two ways to set up the control of the thematic fan #1, either by an on/off command or a PWM proportional control.

**ON/OFF control:** The thematic fan will switch on/off depending on the temperatures that are set. There's also the option to turn on the thematic fan when the A/C is on, to do so select “turn on with A/C”. There's an option that allows one of the fans to be activated when A/C is turned on. As these fans may draw considerable load, a fuel compensation is also available.

**PWM proportional control:** The thematic fan will be controlled by a solid state relay via PWM control, this creates a very linear and progressive control of the engine temperature.

**Turn on by temperature:** If the “Operation Mode” is by “On/Off Control”, the “Enabled” check box must be marked, for the function to be activated, otherwise it will only be configured but not activated for engine control. Electric fan. Set the temperatures at which the electric fan will turn on and off.

**Turn on with air conditioning:** There is also the option of turning on the electric fan at the same time that the vehicle's air conditioning is turned on. If the activation is controlled by a PWM solenoid, it is necessary to adjust the percentage that the electric fan will work. To do so, select the “Turn on with air conditioning” option.

**Fuel compensation:** As an electric fan normally generates an extra load on the engine, a fuel compensation can be included during the first seconds of its operation.

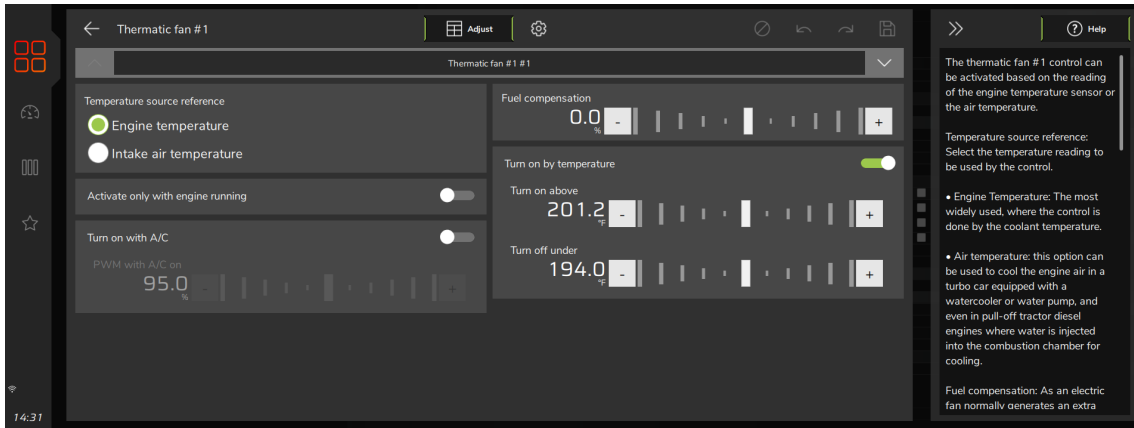

**PWM table by temperature:** This table configures the percentage of activation of the PWM solenoid for each engine temperature. This setting will only be available if the "Operation Mode" is "PWM Proportional control".

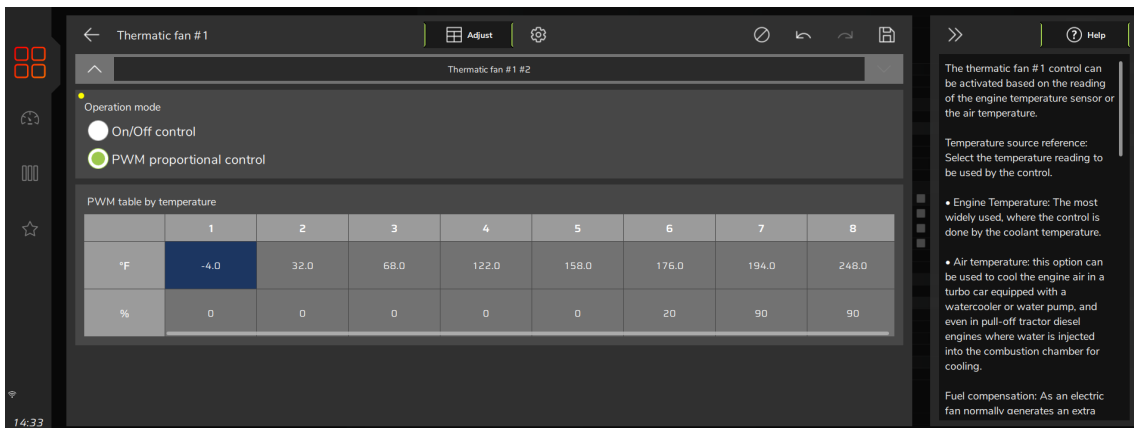

**Output:** Define whether the triggering will be by 0V (using a blue or gray output) or will be by 12V (using a yellow output)

**Output mode:** select which output will trigger the electric fan.

**PWM frequency:** Adjusts the frequency at which the solenoid will work, by default this value is 25Hz.

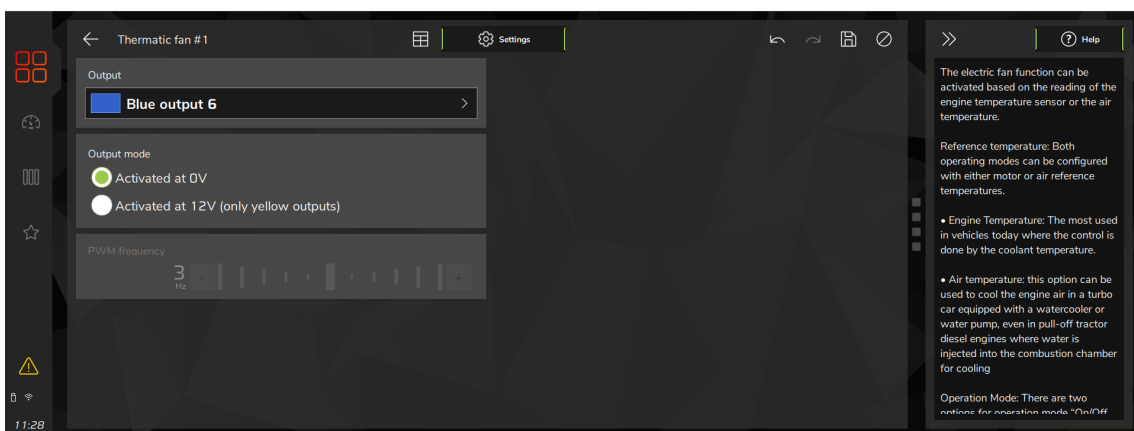

## 20.6 Thematic fan #2

The Thematic fan #2 control can be configured with different temperatures from the electric fan #1. This configuration must be done in the electric fan #2 menu. Select the output you want to use for these actuators and then enter the operating temperatures.

**Temperature source reference:** Select how the electric fan 2 will be activated, there are three options for engine temperature, intake air temperature or transmission temperature.

**Engine temperature:** The most used in vehicles today where the control is done by the temperature of the coolant.

**Intake air temperature:** this option can be used to cool the engine air in a turbo car equipped with a watercooler or water pump, even in pull-off tractor diesel engines where water is injected into the combustion chamber for cooling.

**Turn on with air conditioning:** There is an option to turn on the electric fan 2 at the same time that the vehicle's air conditioning is turned on. To do so, select the "Turn on with air conditioning" option.

**Fuel compensation:** As an electric fan 2 normally generates a considerable extra load on the engine, a fuel compensation can be included during the first few seconds of its operation.

**Turn on by temperature:** enable the function, otherwise it will only be configured but not activated to control fan 2. Define the temperatures at which fan 2 will turn on and off.

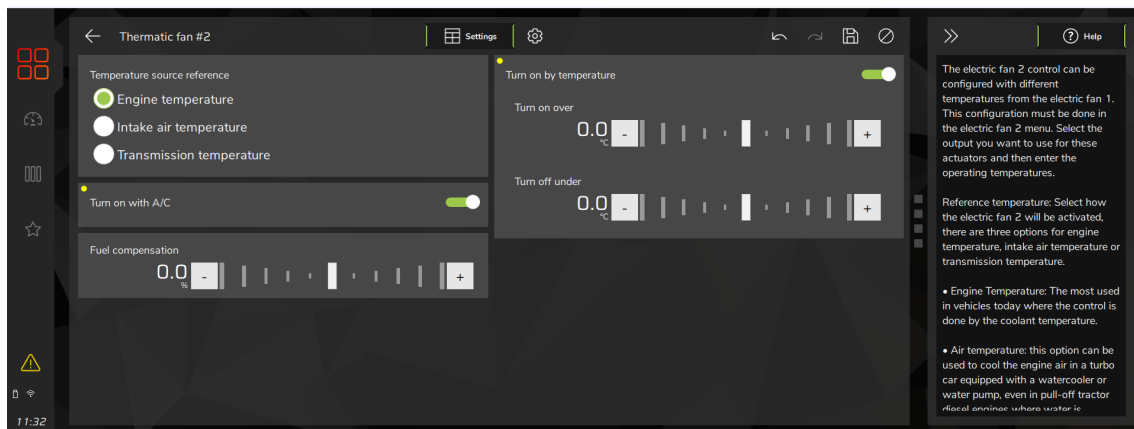

**Output mode:** Define whether the triggering will be by 0V (using a blue or gray output) or will be by 12V (using a yellow output)

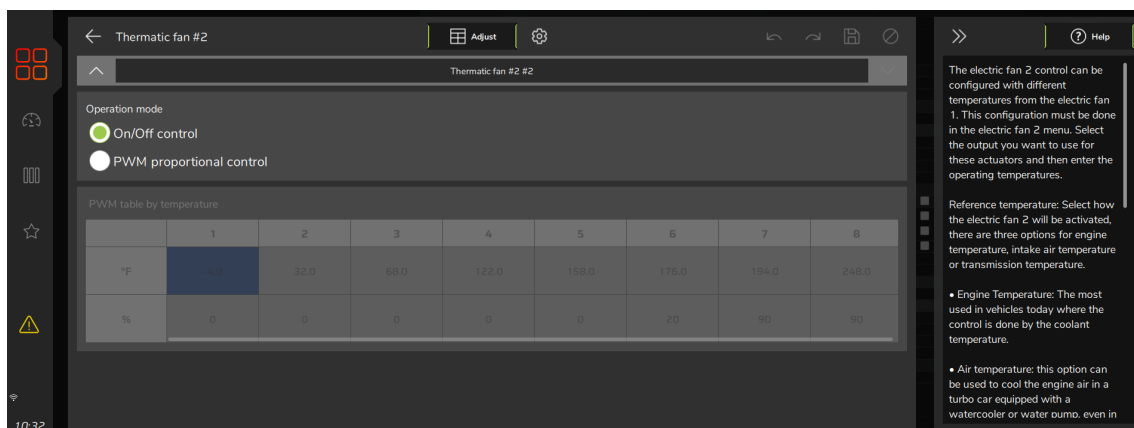

## 20.7 Air conditioning

This function controls the air conditioning by adjusting the injection time when activated.

**Turn off A/C under:** Sets a minimum RPM for turning off the air conditioning, this helps the engine to work when it is at low load.

**Turn off A/C above:** Sets a maximum RPM for turning off the air conditioning, this helps the engine to work when under high loads.

**Turn off A/C with TPS above:** Sets a maximum TPS percentage for turning off the air conditioning, when maximum power is needed it is possible to turn off the air conditioning so that the engine has all the power available at the time of acceleration.

**Fuel enrichment:** Adjust the fuel percentage for activating the air conditioning, this prevents the engine from having a drop in rpm when turning on the air compressor.

**Turn on delay:** It happens on 3 different occasions:

When starting the car with the AC button turned on, the delay time will be counted from the moment the starting RPM is exceeded. In this case, the reference is the motor start, not the moment when the AC button is pressed.

When turning the AC button off and on again, the activation delay will be counted from the moment the AC button is turned off. If the time between turning off and turning on is greater than the delay time, the activation will be immediate.

When the engine RPM falls below the minimum RPM, the shutdown is immediate. The delay time will start counting from the moment the RPM drops below the minimum RPM. To restart, the start delay must have been counted and the engine RPM must exceed the minimum RPM by 500RPM.

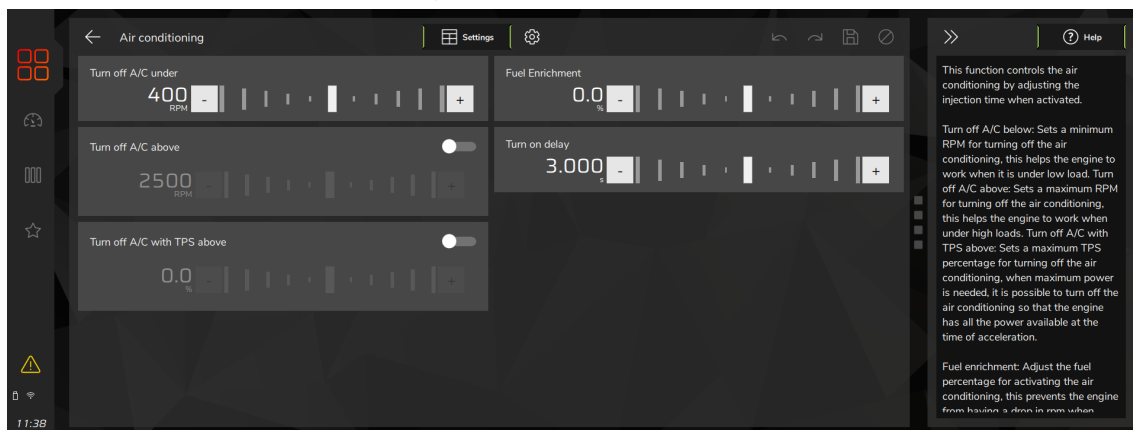

**Activation method:** Configure the trigger type. In the FT700 it is possible to configure multiple input forms for the same function.

**A/C button activation:** If it will be activated by a button (it could be the vehicle's original button).

Activation of the A/C button: To activate the air conditioning through the ECU, it is first necessary to configure an output to activate the A/C compressor relay.

**Output:** Having done this, you must configure the output that will receive the signal from the A/C button, normally located on the car's dashboard, the signal sent by the button can be positive 12V (yellow outputs) or negative 0V (blue outputs) or ashes).

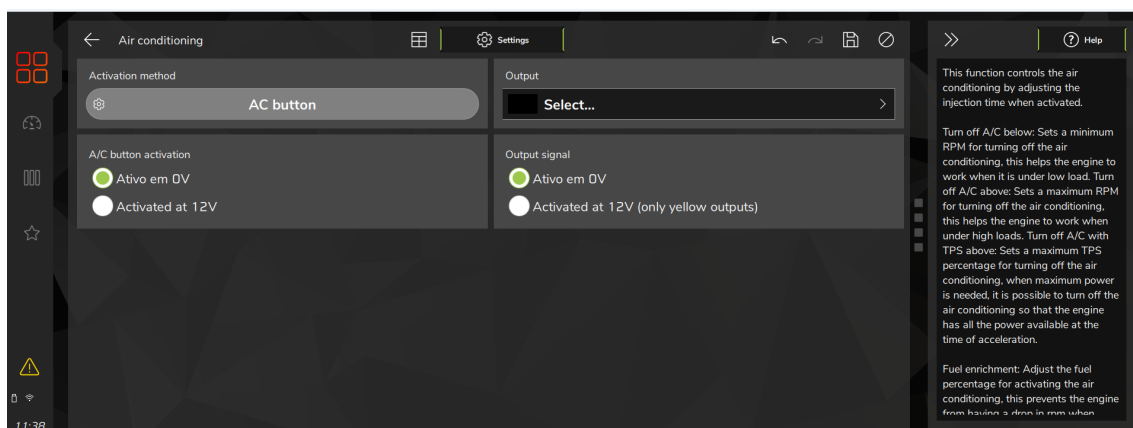

## 20.8 Fuel pump

This output drives the fuel pump through negative or positive, connected to a relay.

**Operating mode:** You can choose between Always On, Timed or During Game modes

- **Always activated:** the output remains activated as long as the ignition key is turned on;
- **Timed:** when turning on the module, the output is activated for a defined activation time, after which the output is deactivated. Upon receiving a rotation signal, the module activates the output again;
- **During starting:** the output remains activated while the motor is in starting mode and the desired time after the motor is in working condition;

**Activation time:** When the timed mode is selected, every time the ECU is energized, the pump is activated for the time programmed here. This activation time field is also used when the During match option is selected.

It is essential to use a relay sized according to the current required to drive the pump.

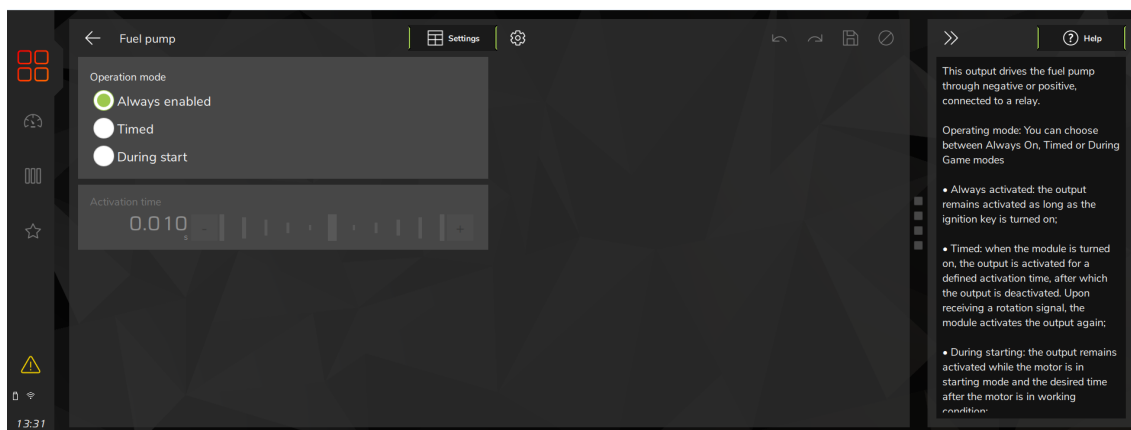

**Output:** Select the output that will trigger the fuel pump relay

**Output Signal:** Active at 0V on gray or blue outputs. In the yellow outputs there is the possibility of triggering by 12V.

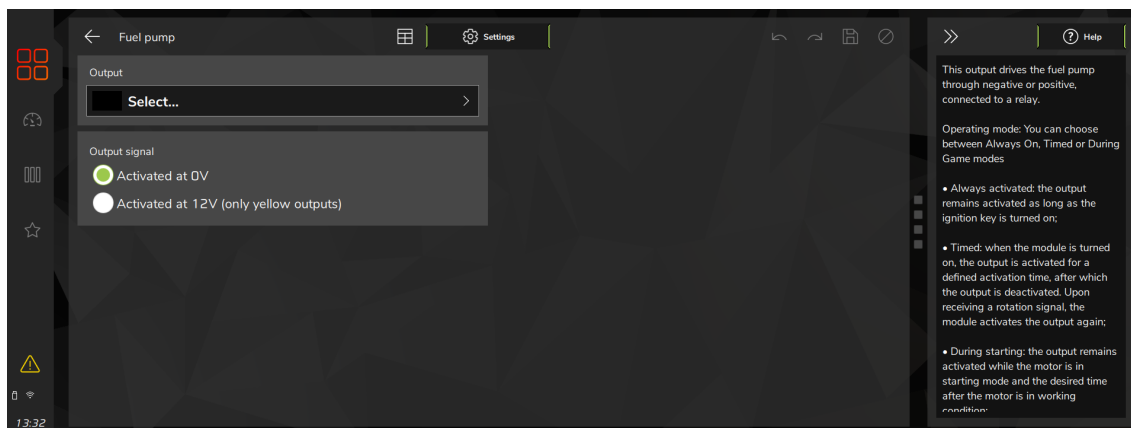

## 20.9 Cold start auxiliary

This feature is very useful for cold starts on methanol and alcohol engines using a gasoline injection auxiliary kit. The table shows the auxiliary injector time versus temperatures.

The ECU will activate the output according to the time set on the table once it detects the first tooth from engine RPM on every engine start.

The cold start auxiliary is disabled when cranking the engine with the accelerator pressed with TPS above the value set in the parameter *"Disable injection on engine start with TPS above"* in the *"Injection"* menu, under *"Engine settings"*.

**Time table by temperature:** This table is composed of a pulse in seconds of the cold start injector depending on engine temperature.

**Output:** Activation through 0V in the blue or gray outputs. The yellow outputs have the possibility to activate the outputs through 12V.

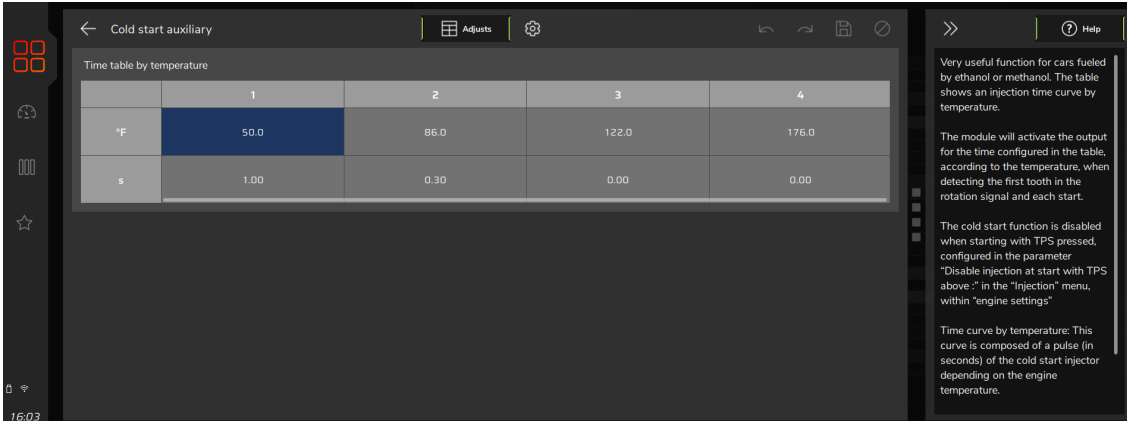

The screenshot shows the 'Cold start auxiliary' configuration screen. The main content is a table titled 'Time table by temperature' with the following data:

	1	2	3	4
*F	50.0	86.0	122.0	176.0
s	1.00	0.30	0.00	0.00

On the right side, there is a help section with the following text:

Very useful function for cars fueled by ethanol or methanol. The table shows an injection time curve by temperature.

The module will activate the output for the time configured in the table, according to the temperature, when detecting the first tooth in the rotation signal and each start.

The cold start function is disabled when starting with TPS pressed, configured in the parameter *"Disable injection at start with TPS above:"* in the *"Injection"* menu, within *"engine settings"*

Time curve by temperature: This curve is composed of a pulse (in seconds) of the cold start injector depending on the engine temperature.

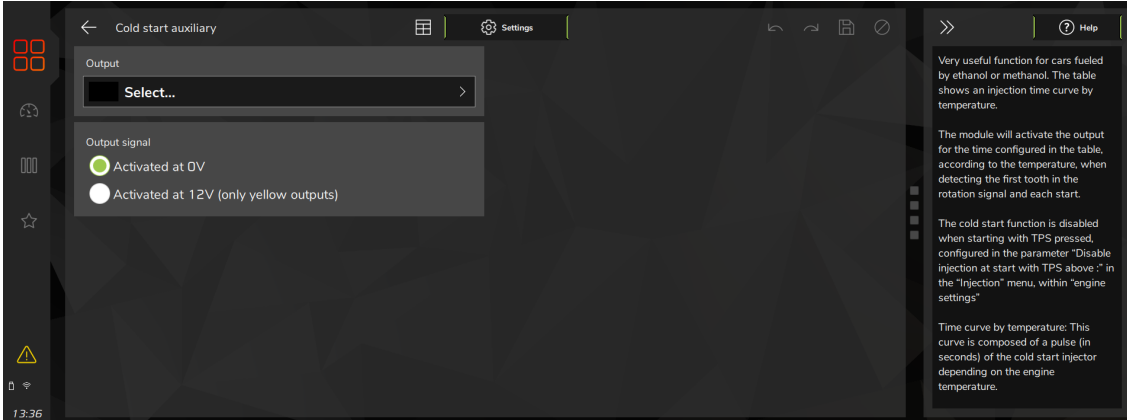

The screenshot shows the 'Cold start auxiliary' configuration screen with the 'Settings' menu open. The 'Output' section is selected, showing a 'Select...' dropdown menu. Below it, the 'Output signal' section has two radio button options:

- Activated at 0V
- Activated at 12V (only yellow outputs)

On the right side, there is a help section with the following text:

Very useful function for cars fueled by ethanol or methanol. The table shows an injection time curve by temperature.

The module will activate the output for the time configured in the table, according to the temperature, when detecting the first tooth in the rotation signal and each start.

The cold start function is disabled when starting with TPS pressed, configured in the parameter *"Disable injection at start with TPS above:"* in the *"Injection"* menu, within *"engine settings"*

Time curve by temperature: This curve is composed of a pulse (in seconds) of the cold start injector depending on the engine temperature.

## 20.10 Variable control (VTEC)

This function makes it possible to activate the variable valve timing (or a 2-speed automatic transmission).

**Turn ON below:** Activate and configure the maximum activation RPM, that is, the RPM value configured in this field will be the command activation upper limit. For example: The function will be activated with 0RPM up to the configured limit.

**Turn ON over:** Activate and configure the minimum activation RPM, that is, the RPM value configured in this field will be the command activation lower limit. For example: The function will be activated with the RPM configured up to the engine RPM limit.

*EXAMPLE 1:* A motor that activates the control actuator at 1000 RPM and stops at 4000 RPM must be configured as follows:

Operate below: 4000 RPM;

Activate above: 1000 RPM;

*EXAMPLE 2:* A motor that drives the control actuator is activated with 0 RPM to 2000 RPM and after 5000 RPM to 7000 RPM, it must be configured as follows:

Activate below 2000 RPM;

Operate above 5000 RPM;

In this way, it is possible to meet all the activation configurations of the variable commands existing in the market.

**Output:** Select the output that will trigger the function

**Output Signal:** Select the output that will trigger the actuator by 0V (blue or Gray outputs) or 12V (yellow outputs).

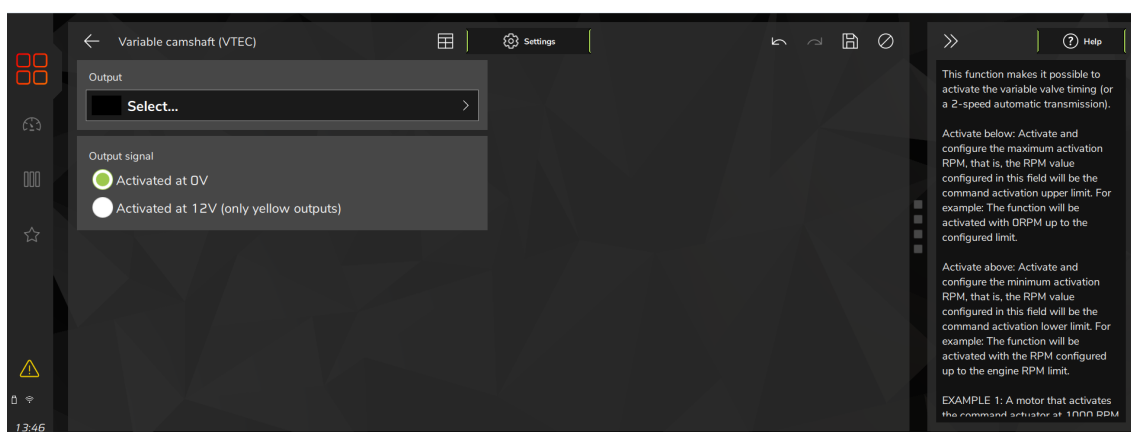
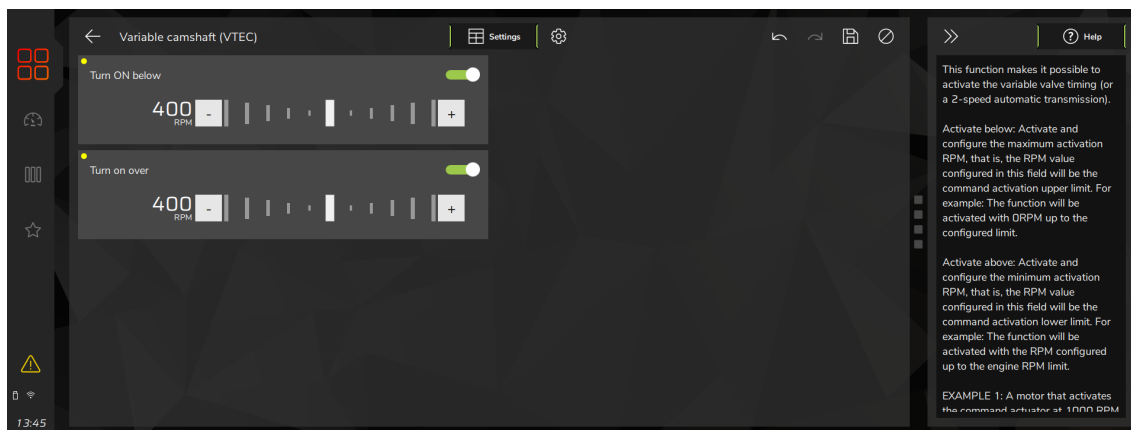

## 20.11 Progressive Nitrous control

This auxiliary output configuration gives access to setting the ratio for the fuel-nitrous mixture (or nitrous only) through pulse-width modulation (PWM) sent to the solenoids.

### Settings

**Control Type:** indicates how the PWM curve will be programmed.

**RPM based:** PWM table is based on engine RPM versus % of nitrous duty cycle. The higher the duty cycle, more nitrous is injected.

**Speed based:** PWM table is based on vehicle speed versus % of nitrous duty cycle. The higher the duty cycle, more nitrous is injected.

**Time based:** PWM table is based on time after 2-step deactivation (vehicle launch) versus % of nitrous duty cycle. The higher the duty cycle, more nitrous is injected.

**Enable progressive nitrous:** allows you to select how the feature will be activated.

**Always enabled:** the Nitrous will always be injected according to the configured PWM curve;

**Progressive nitrous switch:** an external button is used to enable the function;

**Synchronized with the Pro-Nitrous:** follows the activation settings of the Pro-Nitrous.

**Pre launch actuation:** possible to use progressive nitrous control in the 2-step, 3-step or Burnout mode. There is also option of PWM under these conditions, fuel enrichment and ignition timing.

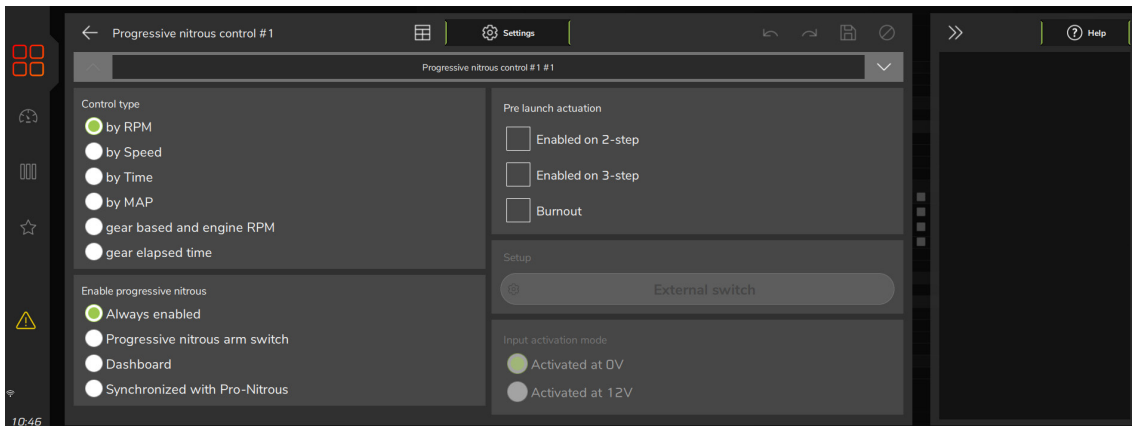

**PWM frequency:** for regular solenoids, use from 25 to 30Hz. For Big Shot solenoids use 50Hz.

**Output Signal:** select here the signal sent from the ECU to turn on the solenoid.

**Disabled when engine temperature under:** prevents the nitrous injection when the temperature is below what's set here.

**Nitrous PWM for pre launch:** allows to use nitrous during the 2-step.

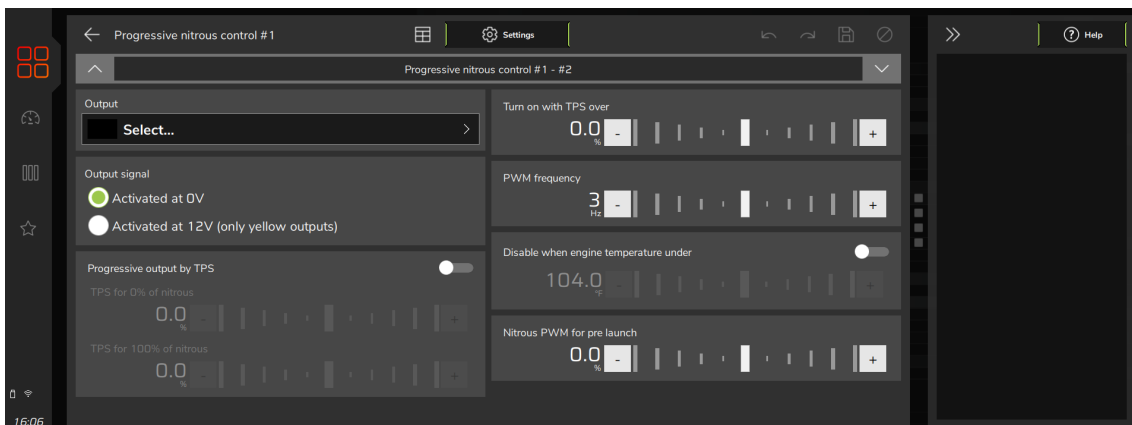

**Fuel enrichment for pre launch:** is the fuel percentage to be added while you are using the progressive nitrous function during the 2-step.

**Timing retard for pre launch:** is the retard to be applied when injecting nitrous on 2-step.

**Lower and upper RPM for activation:** creates an activation window to activate the nitrous.

**Time time to return PWM control:** Progressive nitrous has 3 parameters, TPS, RPM and switch. When nitrous is turned off and then turned on again, it is recommended this return to be progressive, reaching the maximum programmed PWM only after the time set here.

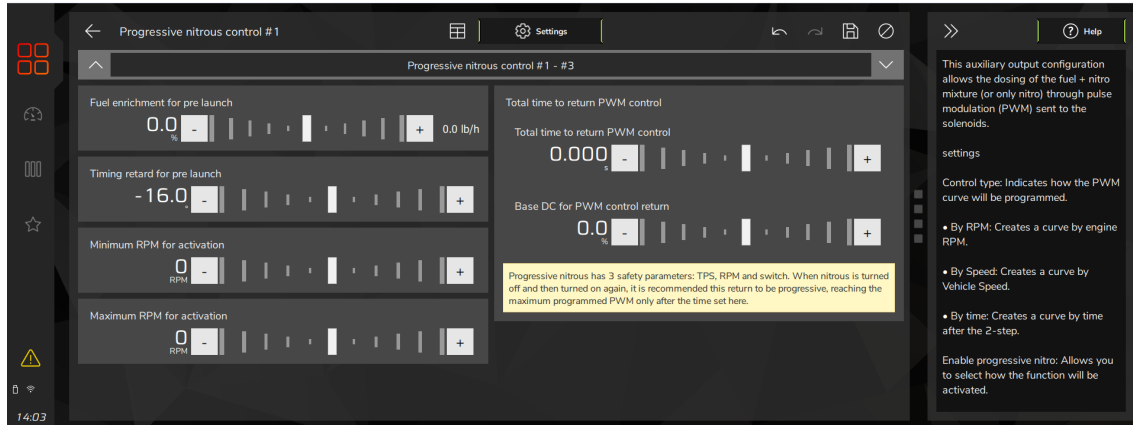

**Fuel and ignition compensations:** Set here delays in time (s) to turn on and turn off the progressive nitro injection and ignition compensations. These delays prevent fuel or ignition timing from being applied to the engine before the nitro actually reaches the combustion chamber, something common to occur in engines that have nitro foggers far from the injectors. The off ramp is a way to smooth the off of these compensations.

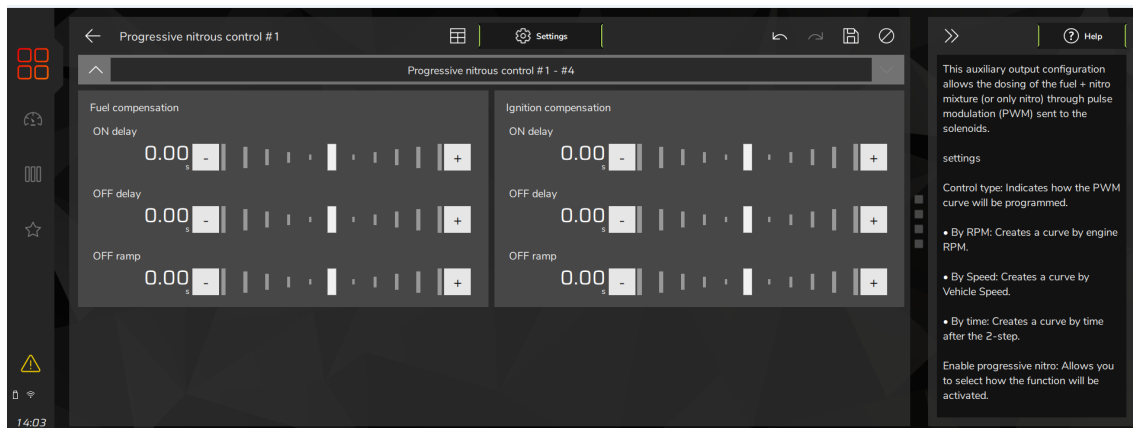

**RPM based nitrous duty cycle table:** This control type allows you to create a RPM based PWM table (opening percentage) of nitrous solenoid.

**Speed based nitrous duty cycle table:** This type of control allows you to create a wheel speed based PWM table (opening percentage) of nitrous solenoid. The recommendation is that the PWM is proportional to the speed. It is based on the drag wheel speed (not traction speed), since if there is a loss of traction, speed reading will be higher than the real speed, and therefore the amount of injected nitro will be higher, increasing the loss of traction.

**Time based nitrous duty cycle table:** This type of control allows the creation of a time based nitrous solenoid PWM table (opening percentage). This mode is for drag race only, cause, the time starts after the deactivation of the 2-step.

**MAP based nitrous duty cycle table:** This type of control allows the configuration of a PWM (percentage opening) curve for nitrous solenoid based on MAP sensor reading.

**Progressive fuel table by nitrous duty cycle:** The fuel compensations are based in this menu percentage numbers, always applied on both injectors banks (A and B when configured). It's possible to tune in lb/h, as long as the flow rate is configured correctly in the “Fuel Injection” menu within “Engine Settings”.

Since the fuel compensation is based on the percentage in this table, if the fuel bank flow is changed in the map, the flow shown in this table will also change, as it is a direct relationship between the fuel enrichment percentage over the injector bank flow.

*Example:* for 10% enrichment on a bank A with 100lb/h and bank B with 100lb/h of fuel flow, this table will show 20lb/h (10% of 200lb/h) and will apply 10lb/h on bank A and 10lb/h on bank B. If bank B flow rate is changed to 200lb/h, the new flow in the fuel enrichment table will be 30lb/h, as the same 10% set before is now calculated on 300lb/h now (100lb/h of bank A and 200lb/h of bank B), and 10% fuel enrichment will be applied to the engine (10lb/h) on bank A and 10% (20lb/h) on bank B.

**Fuel Enrichment by MAP:** This percentage is applied to injection time, making them longer in order to keep up with the engine.

**Fuel Enrichment by TPS:** This percentage is applied to injection time, making them longer in order to keep up with the engine.

**Progressive timing table by nitrous duty cycle:** Table that relates timing compensation versus nitrous duty cycle. It is applied over the main timing table when nitrous is active, according to nitrous duty cycle being injected.

**Auxiliary timing retard compensation:** Table that relates timing compensation versus engine RPM. It is applied over the main timing table when nitrous is active.



of control allows the creation of a PWM (open percentage) map of the nitro solenoid by time. This mode is only for drag races.

Nitro PWM curve by MAP: This type of control allows the configuration of a PWM (percentage open) map of the nitro solenoid by MAP.

Enrichment by %PWM: Fuel compensations are applied based on the percentage entered in this menu, always on the two injection banks (in case of using two banks). The value in lbh can be edited, as long as the flow rates of the benches are correctly filled in the "Injection" menu, within "Engine Settings".

MAP Enrichment: The RPM MAP enrichment map setting refers to the fuel enrichment percentage for 100% nitro. This percentage is applied to

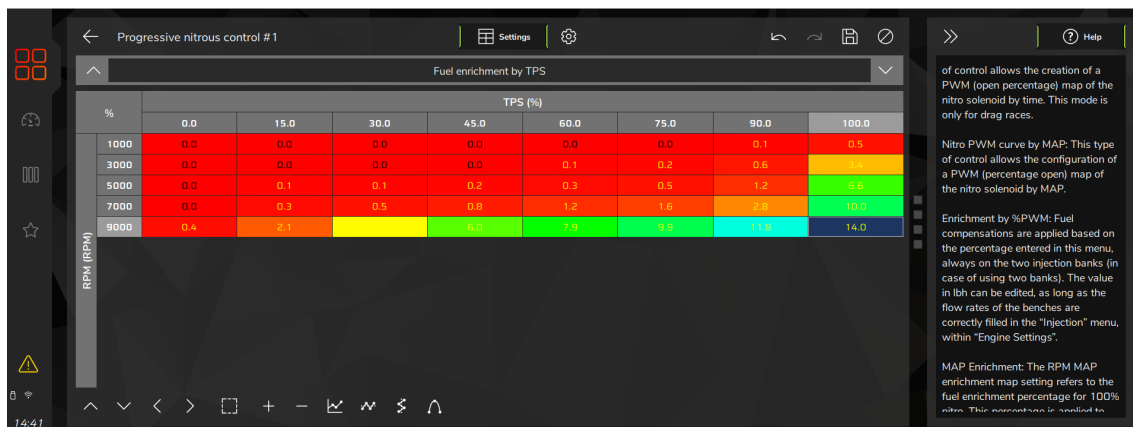

of control allows the creation of a PWM (open percentage) map of the nitro solenoid by time. This mode is only for drag races.

Nitro PWM curve by MAP: This type of control allows the configuration of a PWM (percentage open) map of the nitro solenoid by MAP.

Enrichment by %PWM: Fuel compensations are applied based on the percentage entered in this menu, always on the two injection banks (in case of using two banks). The value in lbh can be edited, as long as the flow rates of the benches are correctly filled in the "Injection" menu, within "Engine Settings".

MAP Enrichment: The RPM MAP enrichment map setting refers to the fuel enrichment percentage for 100% nitro. This percentage is applied to

## 20.12 Generic duty cycle control

This feature allows the control, through PWM, of a solenoid valve that manages the wastegate valve, therefore regulating the boost pressure. Through an external button, you can activate the Boost+ function (optional use), which is an instant increase in the boost %DC while the Burton is turned on.

FuelTech recommends using a 3-way button N75 solenoid.

**Control Type:** indicates how the PWM curve will be programmed.

**Proportional output:** interpolates the PWM curve with the TPS. Instead of reaching the PWM value set in the curve only when the TPS exceeds the minimum position, this option allows the PWM solenoid starts pulsing according to TPS for 0% of PWM and TPS for 100% of PWM.

**PWM frequency:** set the PWM frequency which the solenoid will pulse.

**Output:** select here the signal sent from the ECU to turn on the solenoid.

**2-step / 3-step / Roll start / Pit limit / Burnout PWM:** allows to use PWM control during the conditions

**Generic duty cycle increase button:** is an optional function that increases a configurable PWM percentage. An input (white wire) is required. This feature starts pulsing the output as soon as the ECU reads RPM signal during cranking.

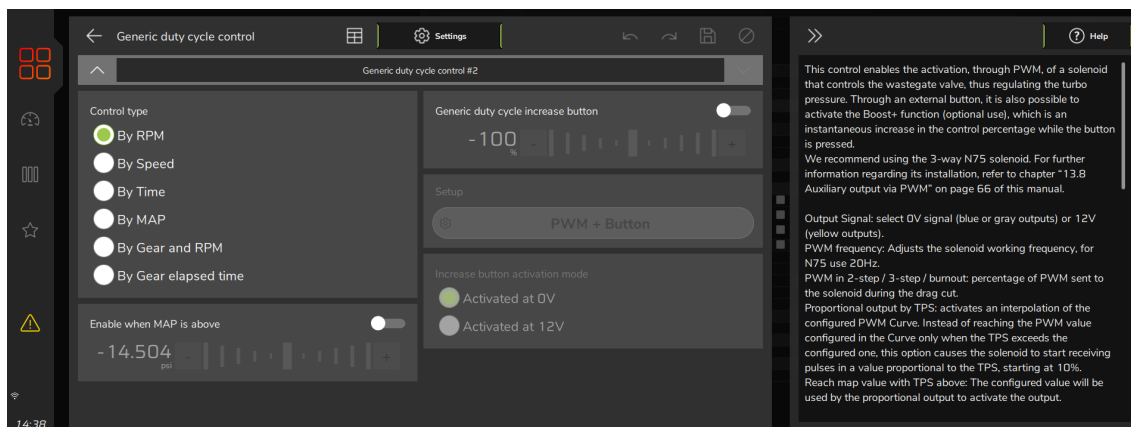
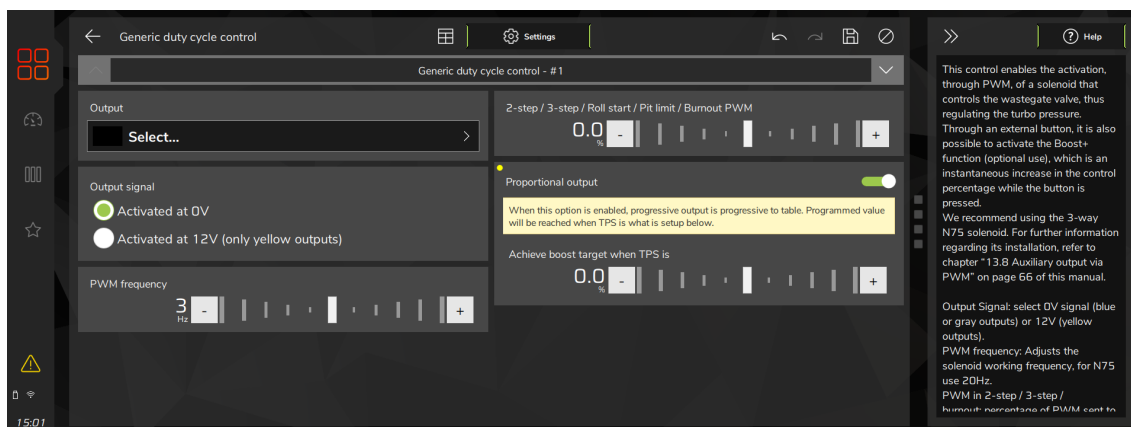

**RPM based duty cycle table:** This control type allows you to create a RPM based PWM table (opening percentage). This function is similar to the OEM boost control.

**Speed based duty cycle table:** This type of control allows the creation of a wheel speed based PWM table (opening percentage).

**Time based duty cycle table:** This control type allows you to create a time based PWM table (opening percentage). This mode is for drag race only.

**MAP based duty cycle table:** This type of control allows the creation of a PWM map (opening percentage) for the solenoid/actuator by MAP pressure (vacuum/boost).

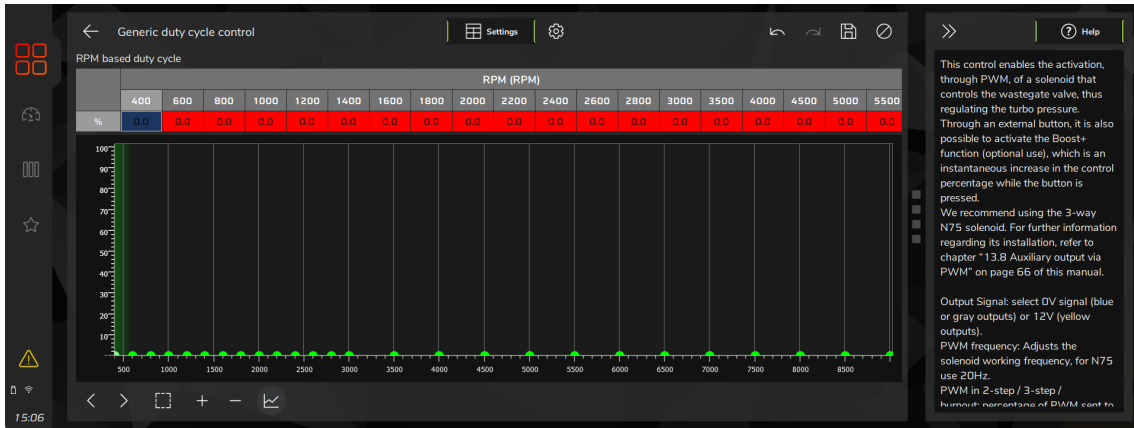

### 20.13 Boost activated output #1 and #2

This function is used to trigger an auxiliary output according to the MAP sensor readings. You can use the built-in sensor or an external one.

**Turn on above:** boost/vacuum above which the output is active

**Turn off above:** boost/vacuum below which the output is deactivated.

**Activation mode:**

**Always active:** if the boost/vacuum set is exceeded, the output is activated.

**Activated only on 2-step:** the output is enabled only if the boost/vacuum set is exceeded and the 2-step is activated.

**Deactivated on 2-step:** the output is enabled only if the boost/vacuum set is exceeded and the 2-step is deactivated.

**Minimum RPM to trigger:** Set here the minimum RPM to activate the output. In this case, the output is enabled only if the boost/vacuum set is exceeded and the RPM exceeds the set here.

**Minimum TPS for activation:** Set here the minimum RPM to activate the output. In this case, the output is enabled only if the boost/vacuum set is exceeded and the TPS is higher than the set here.

**Output signal:** select the signal the output will send when active.

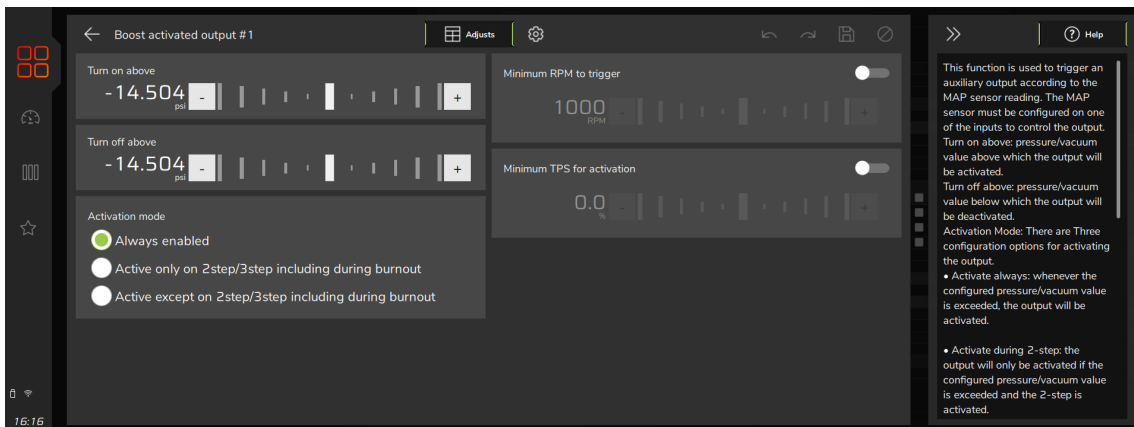

## 20.14 Tach Output

Option to configure the number of pulses per engine cycle (4 strokes) of the tach output. By default, the output will be configured following the number of cylinders in the Engine Settings, Engine Setup menu, but for cases where the stock engine was replaced for another one with different number of cylinders, it is necessary to adjust the number of pulses to maintain compatibility with the stock dash. Also widely used to correctly configure motorcycles dash and external tachometers.

**Synchronized:** Uses the same RPM reading

**Not synchronized:** used to adjust the RPM through the pulses around the engine.

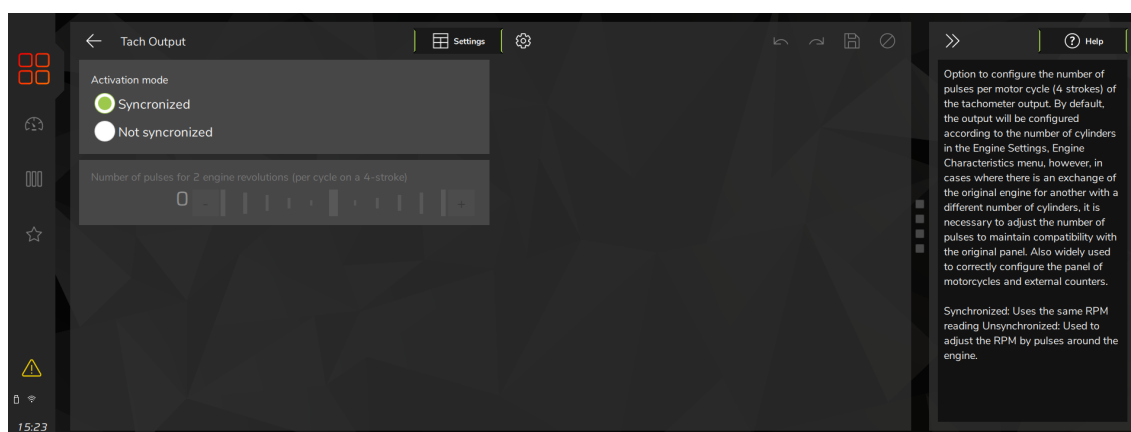

## 20.15 Wastegate Boost Control #1 and #2

The active control function of the wastegate valve pressure is used for a more precise control of turbo pressure in street, circuit and, mostly, drag race cars. The control can be performed by time after 2-step, by gear and engine RPM, by gear elapsed time, by a single target or by engine RPM, besides specific targets for 2-step, 3-step and burnout mode.

When using more than 1 wastegate (compound systems), Wastegate Boost Control #2 function can be enabled to have a completely different setup between the 2 wastegates, extracting maximum performance of each turbo. To activate Wastegate Boost Control #2 go to Engine Settings and Map options.

### ! IMPORTANT

- The pressure controlled by BoostController is the pressure at the top of the wastegate valve.
- You can set the maximum MAP pressure and maximum MAP pressure on 2-step.
- When the BoostController is off the target is zero, and each time the read pressure, for any reason, exceeds 1.45psi the decrease solenoid is activated.

## Installation diagram

- |  |  |
|--|--|
| 01 - Decrease solenoid/injector trigger – connected to the yellow output |  |
| 02 - Decrease solenoid   |  |
| 03 - Increase solenoid/injector trigger – connected to the yellow output |  |
| 04 - Increase solenoid   |  |
| 05 - Negative  |  |
| 06 - Intake or CO2 bottle  |  |
| 07 - Pressure sensor   |  |
| 08 - Pressure sensor hose  | 13 - Actuation of 3 way valve or N75                   |
| 09 - Intake;   | 14 - Control pressure Wastegate                        |
| 10 - Free air  | 15 - FT dual valve block                               |
| 11 - Injectors block   | 16 - Connection to second Wastegate or must be blocked |
| 12 - 3 way Valve or N75  |  |

Diagram with regular solenoids

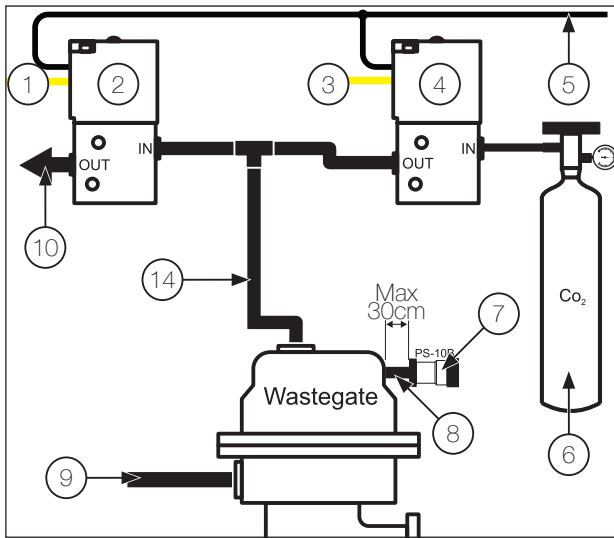

Diagram with N75 Valve

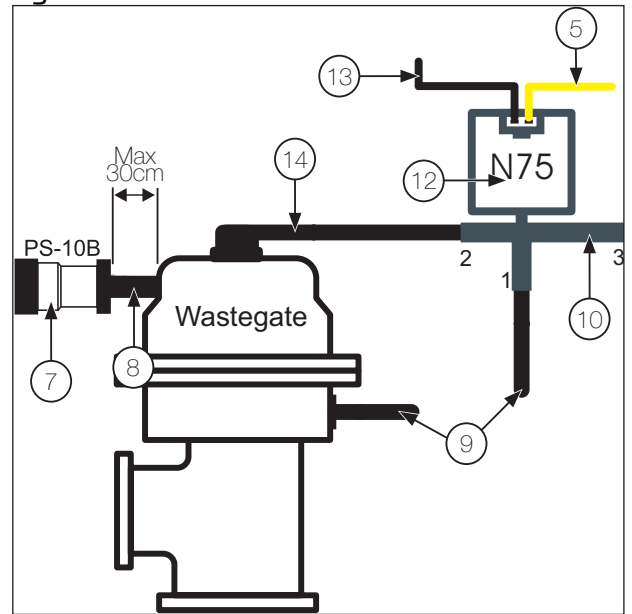

Diagram with injectors block

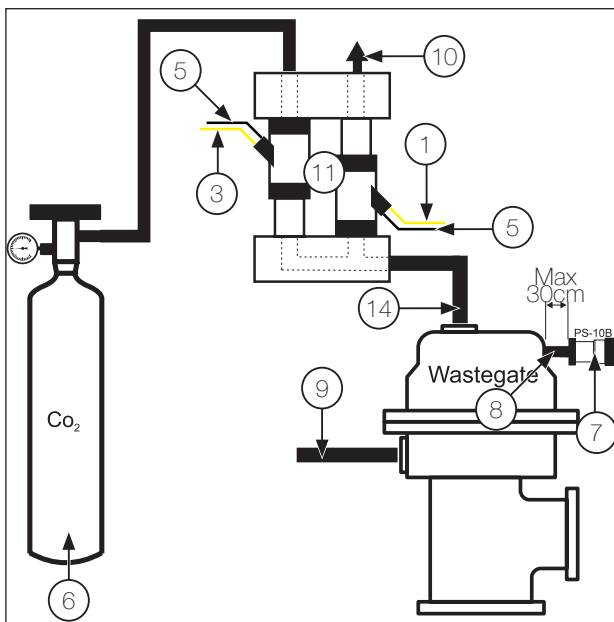

Diagram with FT dual valve block

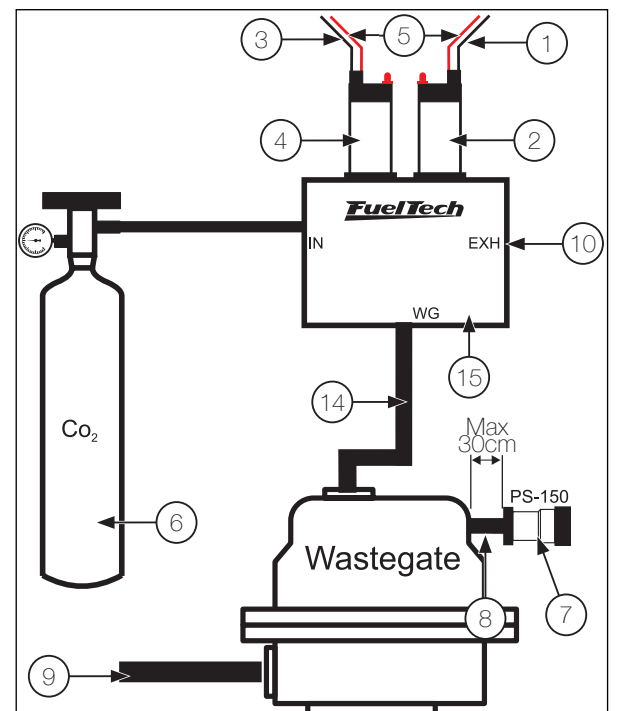
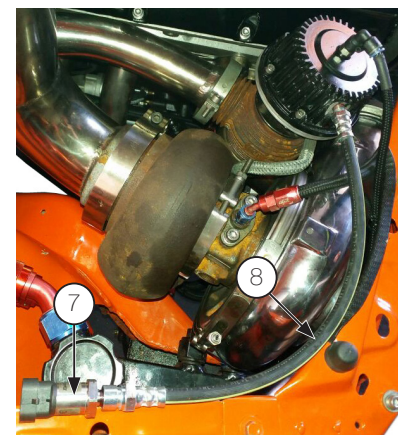
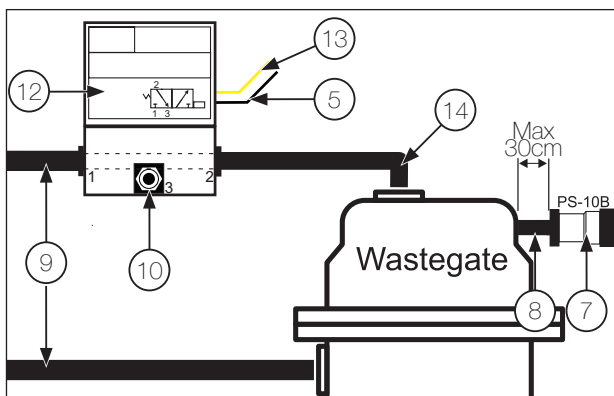

Diagram with 3 way Valve



## NOTES

The pressure sensor (7) must be connected to the top of the wastegate with a hose (8) with a maximum length of 1ft. It prevents damage to the pressure sensor caused by vibration.

## IMPORTANT

Use a PS150 pressure sensor connected to any white input. Setup as "Wastegate pressure".

- The pressure sensor must be installed on an exclusive line, and not shared with any other connection, to avoid reading errors.
- For the correct operation of the system, use only FuelTech PS sensors line: PS-150, PS-300, etc.

**Control type:** there are six options

- **Time based after validated launch:** Allows a detailed ramp up to 32 time points. The intermediate values are interpolated.
- **Gear and engine RPM:** set up a stage for each gear, with up to 8 points per engine RPM. It is necessary that the gear change detection function is enabled. It does not depend on 2-step.
- **Gear elapsed time:** Set up a stage for each gear, with up to 8 time points after the shift.
- **Single target value:** Sets a fixed pressure for BoostController. The wastegate valve will always work this pressure. This mode is recommended for dynamometer tests.
- **Engine RPM:** adjust the wastegate pressure according to the engine RPM in a single stage.
- **Reference speed:** adjusts the pressure according to the reference wheel speed.

**Launch targets:** Adjust values for targets in each condition.

- **2-step target:** Set the target pressure during 2-step.
- **3-step target:** Set the target pressure during 3-step.
- **Burnout target:** Set the target pressure during burnout mode.
- **Launch target:** Boost target for when burnout mode is disabled and the car is not in a valid 2-step start or with the 2-step button pressed.

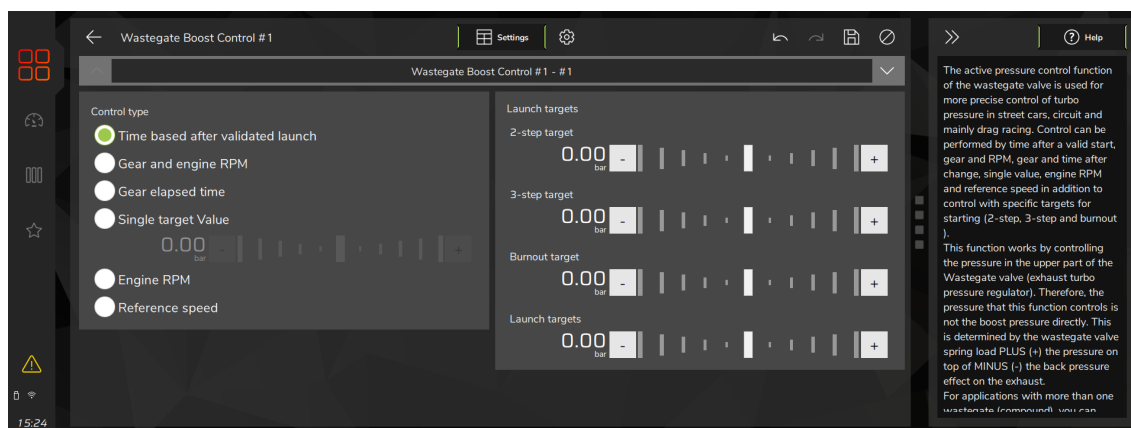

**Boost+ scramble button increase:** While pressed, increases or decreases the pressure at the top of the wastegate valve. Need to configure an input for this button.

**Anti-lag / Pops&Bangs / Engine Brake Target:** Sets the target pressure during these modes.

**Control gain:** Available only when preset mode is selected. This level adjusts how aggressively the function will work to hit targets.

**Proportional gain (KP):** responsible for identifying whether the RPM is far or close to the target to act in control.

**Integral gain (KI):** responsible for checking the RPM evolution trend to try to identify which action the control should take.

**Derivative gain (KD):** evaluates the RPM in recent moments and what the control has done to reach the current speed, it will serve as a standard for the control in the sequence of actions.



**Wastegate target pressure overall trim:** In this function it is possible to make a quick adjustment to adjust the wastegate pressure. Quick tuning is available for all control types.

In the types of control where there is adjustment per gear, the adjustment can be carried out individually for each stage.

It is necessary to have gear detection function enabled to enable gear control types.

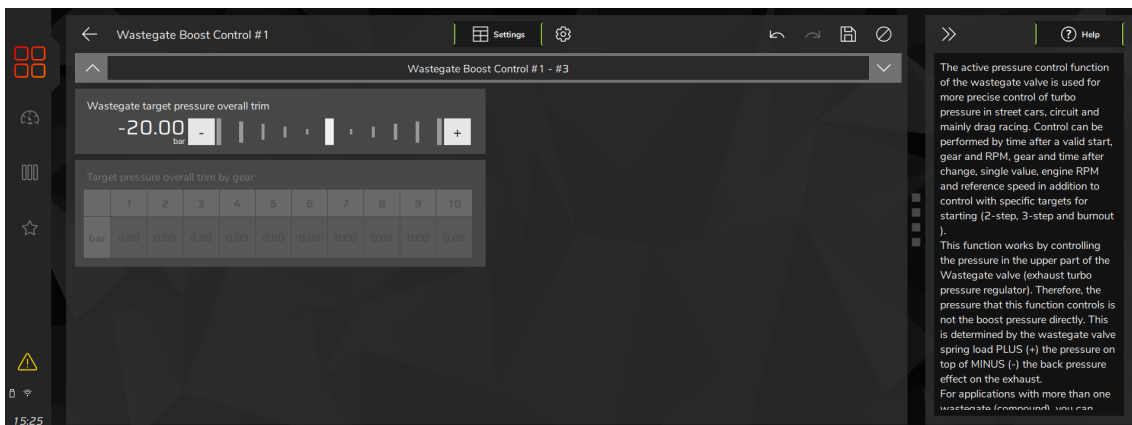

**Time based after 2-step target table:** Allows a detailed ramp up to 32 time points. The intermediate values are interpolated.



**Wastegate boost valve deadtime:** This table allows adjusting the value of the pressure control valve dead time on the wastegate (injectors and boost solenoids - not used for 3-way valve) according to the battery voltage and the pressure difference between the bottle and the pressure on the wastegate.

The battery voltage is shown on the vertical axis and the difference between the bottle pressure and the pressure on the wastegate on the horizontal axis.

**When the pressure fluctuates too much around the target:** reduce the deadtime.

**When the BoostController can't reach the target or it is too slow:** increase the deadtime

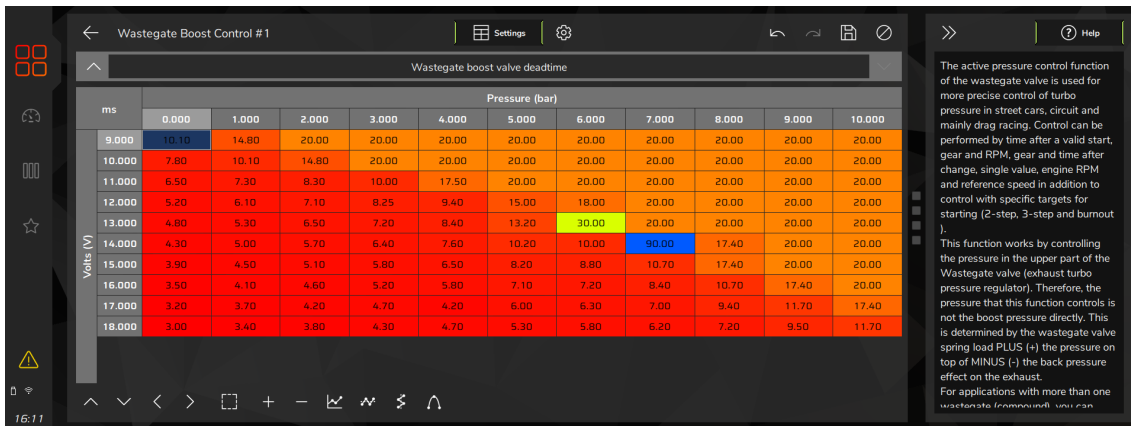

**Pressure Source:** In the BoostController configuration, you will need to inform your pressure source, intake manifold or CO2 cylinder. When using the bottle, it is mandatory to use an industrial pressure regulator, limiting the line pressure according to the desired configuration. Two manometers must be used, one before the regulator, indicating the pressure in the bottle and another after the regulator, showing the pressure in the line.

**Valve type:** Select the type of valve that will be used in the control, two 2-way valves (CO2 compatible) or One 3-way valve (CO2 not compatible)

**Valve model:** It is possible to choose which valve model will be used, high or low flow injector, FT 2-valve block or BoostController2 valve.

**Activate control with TPS or MAP above:** It is possible to configure a minimum value for BoostController activation through TPS and MAP.

**Maximum MAP pressure and 2-step MAP pressure:** In this screen it is possible to configure the maximum MAP pressure and 2-step maximum MAP pressure. (\*This resource will not regulate the turbo pressure by the MAP, it is important to be aware that the turbo pressure will fluctuate around the limit, not being indicated to regulate the turbo pressure, just as a safety device to avoid breakages.

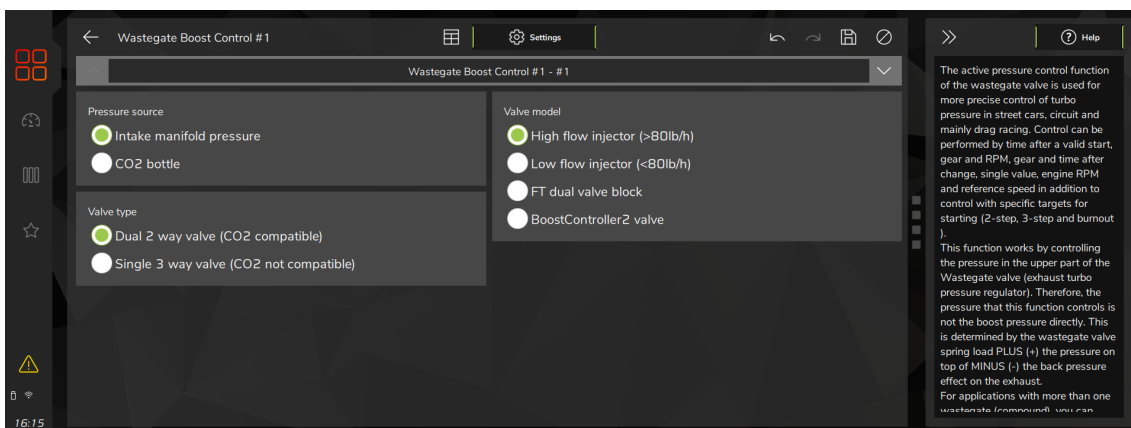

**Proportional Output:** from 10% of TPS the output will be proportional to the map. The programmed value will be reached when the TPS reaches the configured value.

**Output triggering mode:** the output can be triggered at 0V (blue or gray outputs) or 12V (yellow outputs).

**Boost+ button activation mode:** button activation can be at 0V (blue or gray outputs) or 12V (yellow outputs).

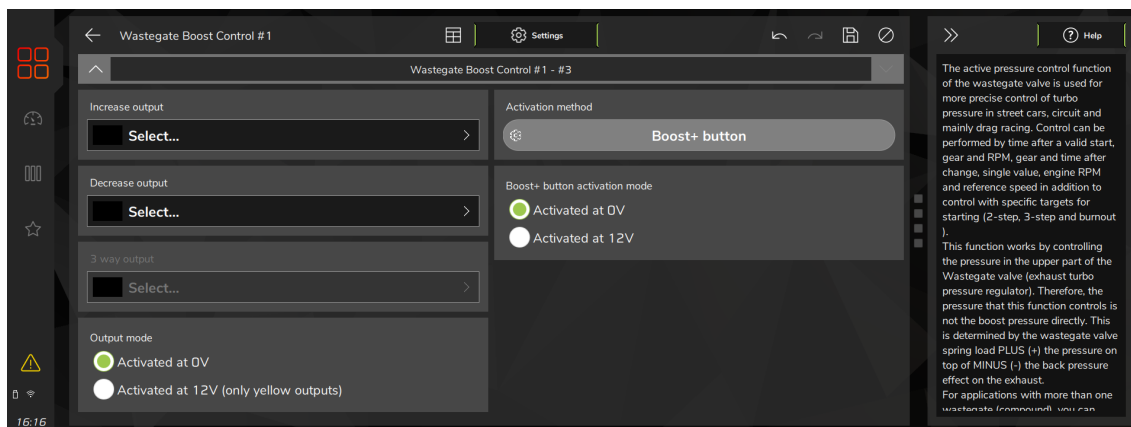

## 20.16 Start button

This function allows controlling the vehicle's starter motor through an output (blue, gray or yellow wires) and an input (white wire) or through the FT screen.

**Setup:** There are two configuration options for the start button, both of which can be configured together.

- **Dashboard / Vision FuelTech:** Activation via the instrument panel on the FT screen (necessary to configure the "Start Button" item on the instrument panel).
- **External button:** Configures an external button to drive the motor.

**Automatic start:** When this option is selected, it is no longer necessary to hold the start button, just one touch and the ECU will start automatically, but some precautions will be necessary, as described below.

- **Configure the Maximum Starting RPM:** when detecting an RPM above the set value, the button is turned off.
- **Maximum cranking time:** Set the time limit that the starter motor will crank.
- **Check that the car is not in gear.**

As long as the instrument panel button (or the external button) remains pressed/activated, the starter motor will be activated. It will only be turned off when releasing the button or until the engine RPM exceeds the starting RPM (configured in the Engine Characteristics menu). As soon as the engine is running, the function of the button on the instrument panel is now to turn off the engine if pressed (by cutting the injection and ignition).

**Starter button protection:** it is possible to enable one or more sensors that condition the starter motor activation for greater safety.

*Suggestion:* for cars with manual transmission, condition with the brake or clutch button and for cars with automatic transmission, select lever in P or N.

**Input activation:** Select whether the input is activated when it receives 0V (ground) or 12V.

**Output activation:** For the output that activates the starter motor relay, select whether it should send 0V or 12V when activated.

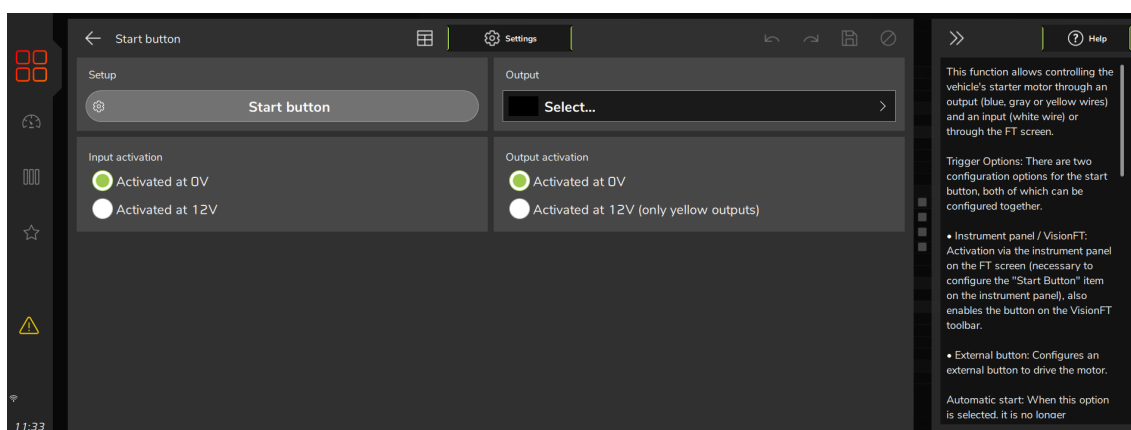
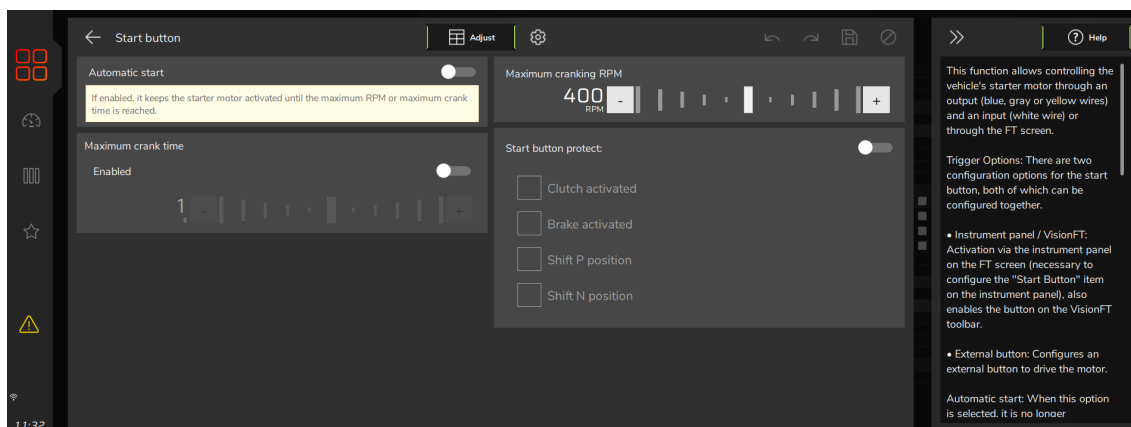

## 20.17 RPM activated output

This function activates an output as soon as the RPM value exceeds the value set here.

Very useful for protecting injectors and coils from overload by activating their relays only after the motor reads some RPM. A very low value, such as 50 RPM, is suggested.

**Enable with RPM above:** Target rotation to trigger output. The output is deactivated when the engine speed falls below this value.

**Output:** Activation through 0V in the blue or gray outputs. The yellow outputs have the possibility to activate the outputs through 12V.

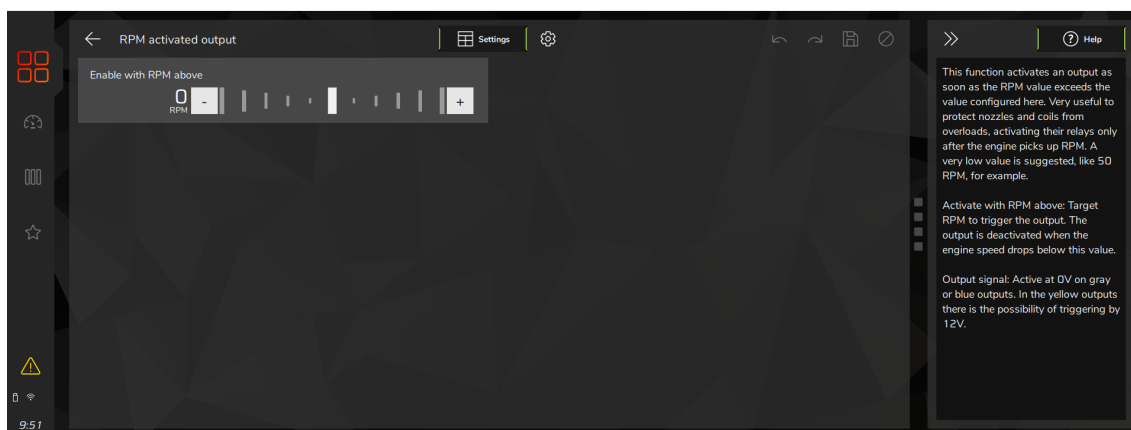

## 20.18 Map selection by button

This function allows the user to setup one or more inputs for quick switching between the maps on the ECU.

**Operation mode:** There are two options of selection by single button or one button per adjustment.

- **Single Button:** One button switches between desired settings
- **One button per map:** Each setting is selected through a different input.

**Switch between maps:** Select the map files you want to be enabled for quick selection by button.

**Button Activation Mode:** Indicate if the single adjustment change button is activated when the input goes to 0V (ground) or to 12V.

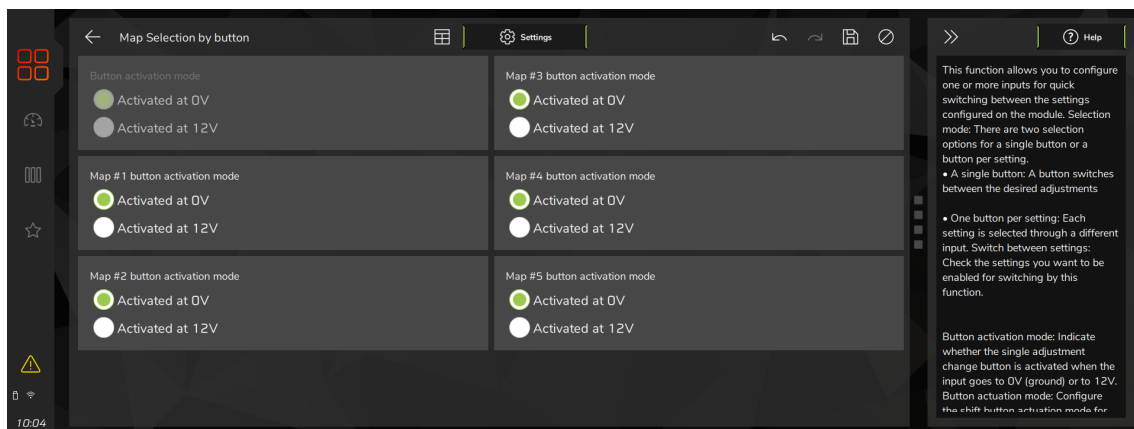
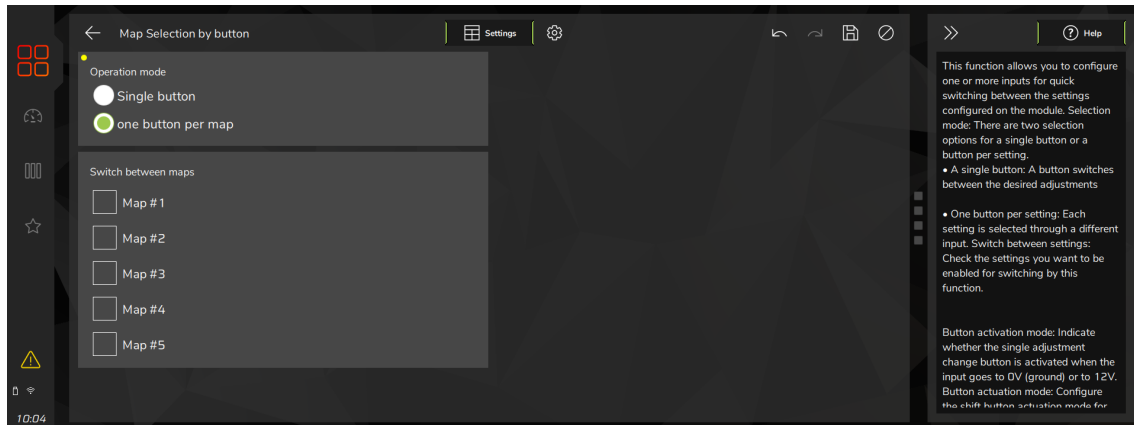

## 20.19 Pit Limit

This function limits car speed when activated. It's required an analog input or a CAN input set as Pit limit switch/button.

**Activation mode:** The activation mode can be configured as dash board, as external button or as external switch. They work as following:

- **Dashboard:** Press one time to activate it and another time to disable it.
- **External button:** The function will be working as long the button is being pressed.
- **External switch:** Switch ON will activate the feature, switch off will turn it OFF.

**Limit speed:** Configures the limit speed for the function.

**Button actuation mode:** In case an analog input is configured, it is possible to choose the way with that the input will be activated, whether by 0V or 12V.

### WARNING

*When the ECU is requested to apply more than one type of ignition cut from different functions simultaneously, the cut with the highest % configured will have priority, so the function with the lowest % of cut might not operate as expected.*

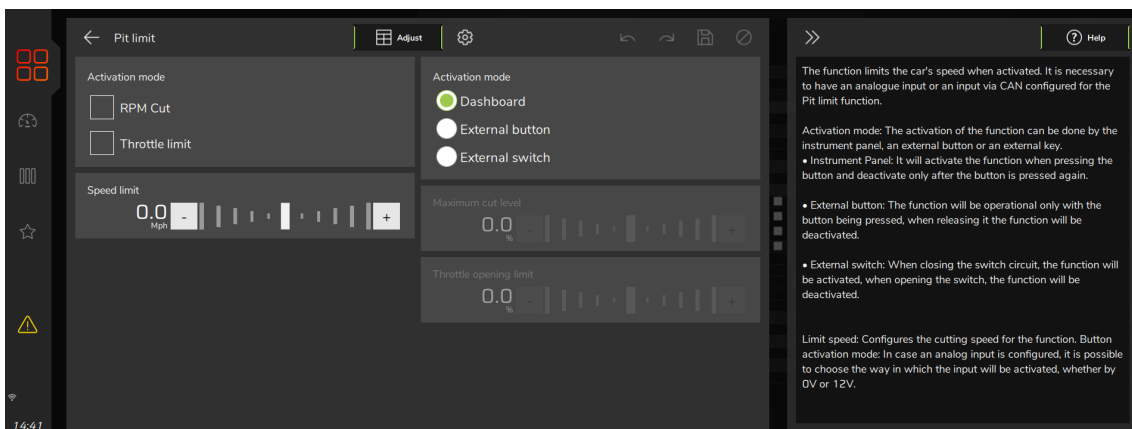

## 20.20 Active Traction Control

This feature controls the wheel speed difference among all the wheels, giving more traction to the car. The ECU retards timing and cut ignition to limit power.

**Control Mode:** There are three options to control

- **Time based after validated launch:** TPS x Time table to set slip targets
- **Engine RPM based:** TPS x Engine RPM table to set slip targets
- **Vehicle speed based:** TPS x Wheel speed table to set slip targets

**Reaction Level:** Higher the number, more aggressive the control will act. Lower levels will be more soft with the engine, but will take more time to be representative.

- **Power Reduction Strategy:** There are two different ways to reduce power and keep slip under control. It's possible to have both strategies enabled.
- **Ignition Retard:** set the maximum retard ECU will apply.
- **Ignition Cut:** more aggressive strategy, allowing to set the maximum ignition percentage.
- **Minimum slip to activate traction control:** Minimum slip rate, below this number ECU will not act.

### NOTES

*For traction control to work, it is necessary to have at least two wheel speeds that have different speeds.*

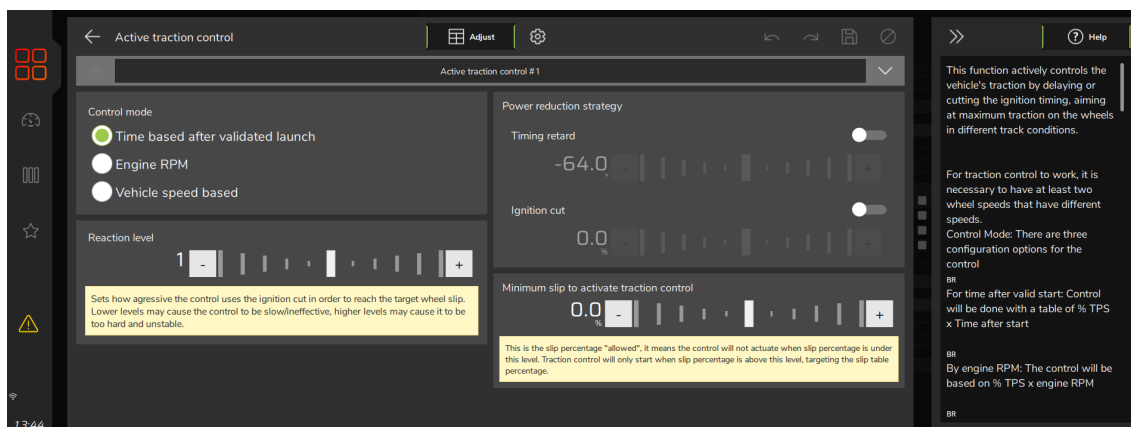

**Minimum RPM:** minimum engine RPM to the ECU act on power.

**Speed to activate (reference speed):** minimum speed to activate the control. Traction wheel will be used as reference.

**Speed to deactivate (reference speed):** maximum speed to activate the control. Traction wheel will be used as reference.

**Disable after gear shift:** in some cases, some slip is interesting to not upset the engine, the traction control can be disabled for a moment.

**Enable after validated launch:** in cases it's not desirable to have the traction control working in the first moments of the pass, it's possible to disable it for a few seconds.

**Enable function by:** select the option below

- **Always enable:** the traction control will be always activated.
- **Only with validated launch:** the traction control will be active only after a validated 2 step signal.
- **Dashboard:** a button on the touchscreen can enable or disable the traction control.

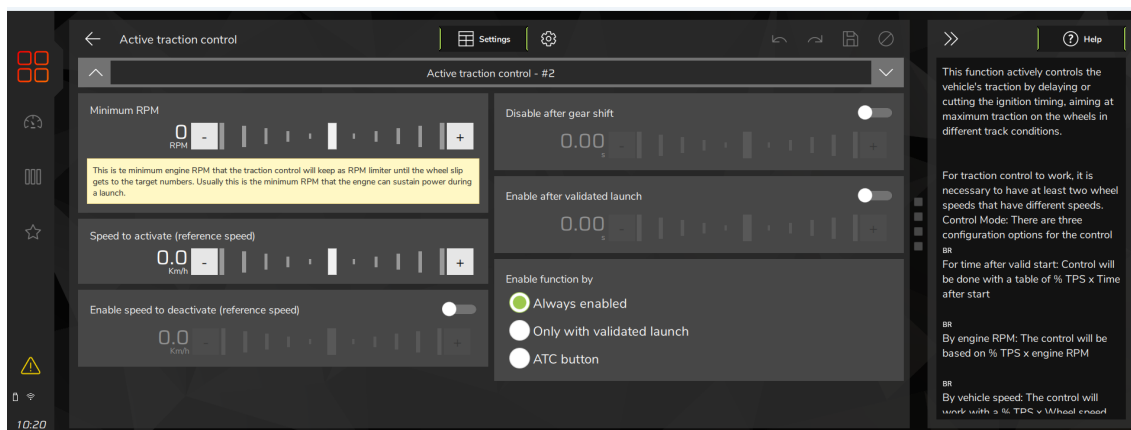

## WARNING

When the ECU is requested to apply more than one type of ignition cut from different functions simultaneously, the cut with the highest % configured will have priority, so the function with the lowest % of cut might not operate as expected.

**Time based slip target table #1:** Traction control strategy also uses TPS percentage as a driver feedback. When driver decreases throttle percentage, means less power to the wheels is demanded, so traction control will be more aggressive to close wheel speed gap.

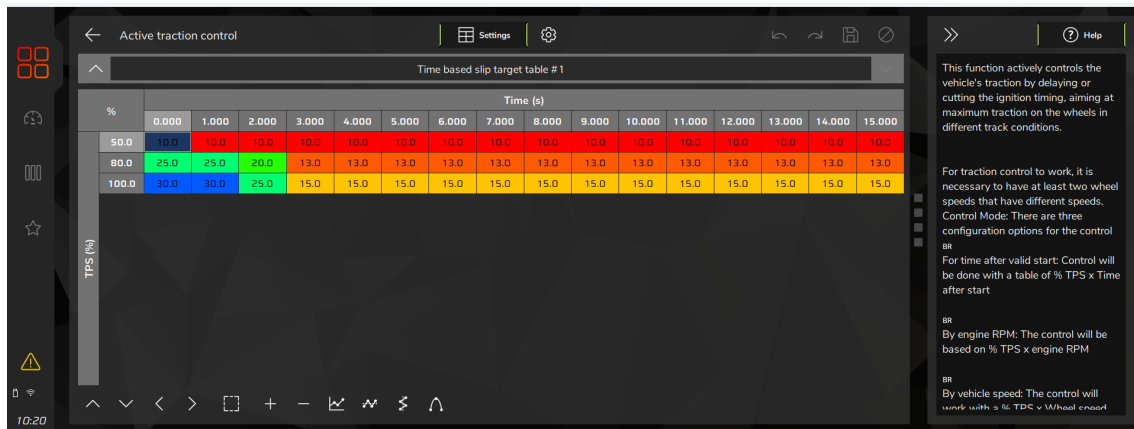

**Table selection mode:** Select the option

- **Dashboard:** it's possible to change traction control tables using a dashboard button.
- **Gear based:** each gear will have a different traction control table.
- **External analog switch:** it's possible to set a multistage switch to select different tables for traction control.
- **External button (one per table):** an external button can change traction control table. This option uses one button for each table.
- **External button (previous/next):** and external button can change traction control table. This option uses just one button to go over all tables.

**Number of slip target tables:** It's possible to have up to 6 different traction control tables, having different targets and different TPS percentages.

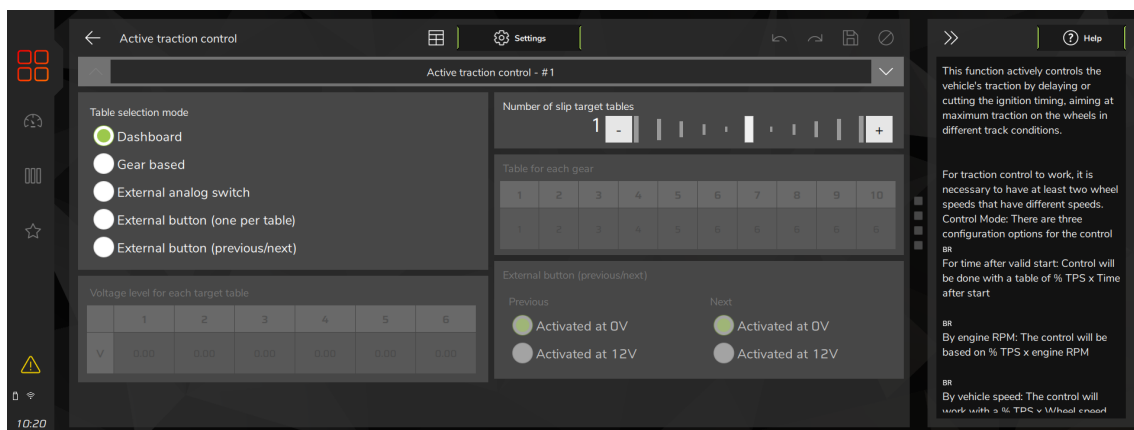

## 20.21 Generic output

Generic outputs allows to set an analog input, a CAN button using SwitchPanel or a dashboard button to activate any output, for example exhaust diverter, or alternator during drag races.

It's possible to set if the output will be activated as long the button is being pressed or if the output will turn on when press the button and then turn off when pressed again. Input and output activation mode is also configurable in this menu.

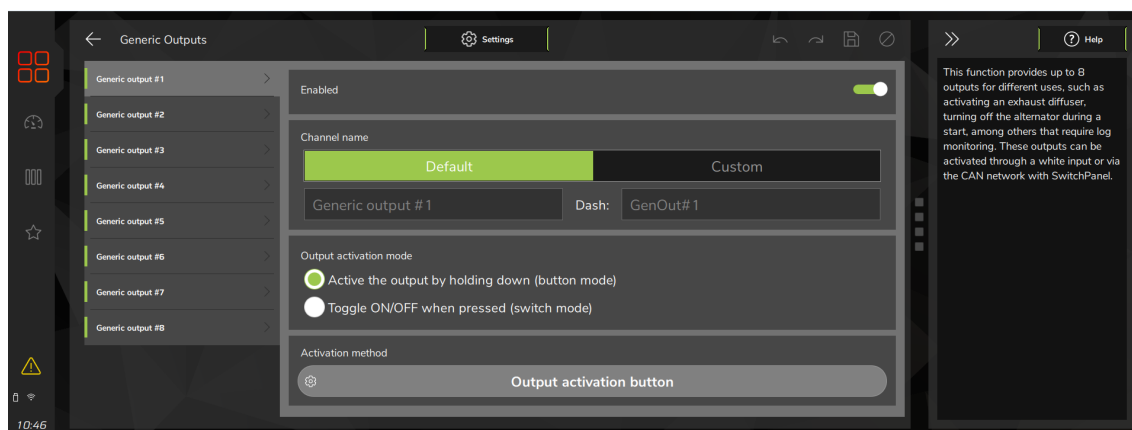

## 20.22 Flex fuel

Flex Fuel feature has up to 7 compensation tables to adapt the tune to ethanol percentage used. Ethanol percentage reading comes from a Flex Fuel sensor installed in the fuel line and wired to one of the FuelTech analog inputs. The same sensor is also capable of reading fuel temperature. According to ethanol percentage, the ECU will use the tables to apply all necessary compensations.

**Default blend in case of error on flex fuel sensor:** if the sensor is disconnected or has a malfunction, the ECU will use the compensations according to this value.

In order for the ECU to apply the right compensation from the tables, it's possible to ignore the readings from the sensor on certain situations:

- Discard reading during engine start (where the drop on battery voltage may affect the sensors 12v power supply) and use values read before cranking
- Discard reading under high load (where the high flow of fuel may affect the sensor readings) and use only below 2500rpm

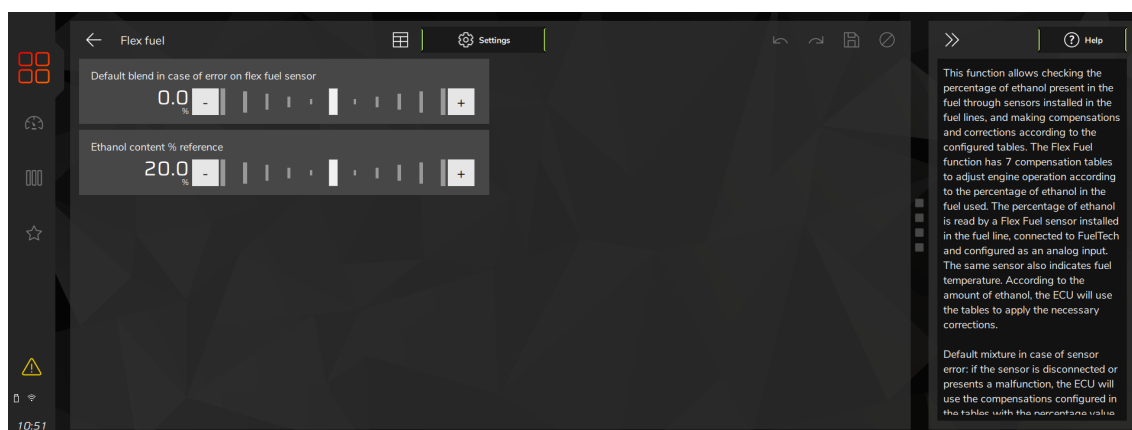

**Main fuel injection compensation:** The main fuel injection table works real time over the main fuel map, compensating the fuel need according to the ethanol percentage in the tank. One of the axis on the table is ethanol percentage, the other is MAP or TPS (depend of main fuel table setting) and the amount of fuel to be added or subtracted must be placed in the table cells.

For a 100% ethanol mapped engine, as ethanol percentage decrease, less amount of fuel is required, so the values in the table will normally be negative.

For a 100% gasoline mapped engine, as the ethanol percentage increases, more amount of fuel is needed, so the values in the table will be positive.

		Ethanol Percent (%)					
%		0.0	10.0	40.0	75.0	85.0	100.0
MAP (bar)	-0.350	-9.3	-4.9	10.3	28.2	33.4	41.0
	0.000	-9.5	-5.0	10.5	29.0	34.2	42.1
	0.690	-10.2	-5.4	11.3	31.2	36.9	45.4
	3.100	-11.9	-6.3	13.5	37.1	43.9	54.0

This function allows checking the percentage of ethanol present in the fuel through sensors installed in the fuel lines, and making compensations and corrections according to the configured tables. The Flex Fuel function has 7 compensation tables to adjust engine operation according to the percentage of ethanol in the fuel used. The percentage of ethanol is read by a Flex Fuel sensor installed in the fuel line, connected to FlexTech and configured as an analog input. The same sensor also indicates fuel temperature. According to the amount of ethanol, the ECU will use the tables to apply the necessary corrections.

Default mixture in case of sensor error: If the sensor is disconnected or presents a malfunction, the ECU will use the compensations configured in the table with the maximum value.

**Engine start and Prime pulse compensation:** Fuel percentage compensation table for prime pulse and engine start according to the percentage of ethanol used. Based on a ethanol tune, ethanol percentage decrease requires negative compensation to start the engine. For gasoline based map, raising the ethanol level requires positive compensation to start the engine.

**Acceleration fuel enrichment compensation:** Acceleration fuel enrichment compensation can be adjusted to add or remove fuel using an ethanol percentage table. Usually, ethanol engines require more acceleration fuel enrichment than gas tuned engines.

**O2 closed loop target compensation:** O2 closed loop target table is based on ethanol percentage and MAP or TPS (depending of main fuel table settings). All the values set on the table will be added or subtracted to the main closed loop table and interpolated according to engine RPM. Usually closed loop targets change according to the fuel, for performance and engine safety, in most cases targets for ethanol are lower than when using gas.

**Main ignition compensation:** It is possible to adjust ignition compensations depending on ethanol percentage, the table is also related to MAP or TPS reading. The values set in the table are in °BTDC and are added to the ignition map, interpolating MAP or TPS with engine rpm to obtain the final value.

**Wastegate boost control compensation:** When the BoostController feature is enabled, it is possible to change pressure targets in the wastegate according to ethanol percentage, adjusting engine power to the fuel used. The values added in the table are added or removed in BoostController function maps, even in cases of different pressures per gear, 2-step, 3-step, Burnout or Pre-Start target pressures.

**Generic duty cycle compensation:** When turbo pressure is controlled by generic duty cycle output, ethanol percentage can also change the pulse frequency that opens / closes the wastegate, adjusting the engine power to the fuel used. The value entered in the table is added to the original PWM curve of the map.

## 20.23 Blip / Heel and Toe

The blip/heel and toe feature quickly opens or closes the throttle when shifting gears.

The feature adds a percentage of opening in the throttle channel, so if you have the TPS at 20% and blip configured to add 60%, the final opening will be 80%. And, even if some function is limiting the opening of the throttle (custom pedal/throttle curves or maximum electronic butterfly opening), the blip function will still achieve its target, even if it exceeds the maximum value configured in these functions.

### Activation method

- **External button:** Uses a white input to receive a blip signal;
- **GearController cut:** Applies blip with the Power Shift function;
- **Gear Control Management - GCM function:** Applies blip when with GCM function;
- **Automatic transmission control:** Applies blip when shifting through the automatic transmission control;
- **Brake + Clutch:** Applies the blip when the brake and clutch pedal inputs are activated simultaneously. It is suitable for cars with standard manual transmissions;

**Button activation mode:** Choose whether the function will be activated by 0V (ground) or positive (12V)

Output for mechanical throttle: Enables a pulse output to open a mechanical throttle through an actuator/solenoid that pulls the throttle cable.

Output Signal: Choose whether the function will be activated by 0V (ground) or positive (12V)

## NOTES

*This feature has been developed to work with an external sequential shift control module with electric or pneumatic actuator with a specific blip control output. The use of this feature on street cars without this type of controller requires connection with external relay and brake and clutch signals to activate the blip during gear-shifts.*

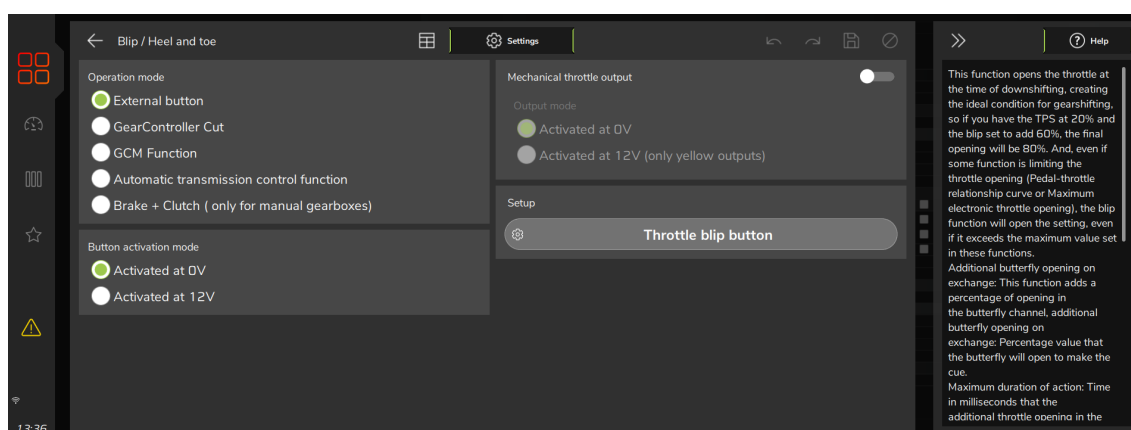

## 20.24 Variable camshaft (VVT)

This feature enables programmable control for the advance and retard of camshaft position to ensure optimal performance across different loads and RPM ranges. It can control up to 4 camshafts (2 intake and 2 exhaust).

Use the check boxes to enable the camshafts that will be controlled by the ECU

**Sensor type:** There are two options.

- **Cam sync sensor:** Uses the same cam sync sensor set up using the dedicated cam sync input for engine synchronization.
- **Analog input (Hall sensor):** A hall effect sensor installed in the camshaft and wired to one of the analog inputs.

**Output signal:** The actuator solenoid can be triggered wither by 0v (blue and gray outputs) or 12v (yellow outputs).

**PWM frequency:** The amount of pulses in Hz that the actuator uses.

**Minimum and maximum duty cycles:** The minimum and maximum range of duty cycle that the solenoid will use when operating.

**Base duty cycle:** The duty cycle in which the solenoid will rest at when not actuating.

**Solenoid direction:** The direction the actuation of the solenoid moves the camshaft to.

- **Normal (advance):** This option will use the values set in the target tables as an increment. Example: if a value of 20° is used, the camshaft will be advanced in relation to the physical position of the sensor.
- **Inverted (retard):** This option will use the values set in the target tables as a decrement. Example: if a value of 20° is used, the camshaft will be retarded in relation to the physical position of the sensor.

**Proportional gain:** How fast the control tries to reach the target.

**Integral gain:** Is the accumulated error over time, that should have been corrected, from the proportional gain trying to reach the target.

**Derivative gain:** Smooths out the approach and overshoot and stabilizes the control around the target.

**! IMPORTANT**

Check the physical limitations of your variable camshaft. In case this feature is improperly used, it may cause irreversible damage to the engine (valves hitting each other or the piston, specially when using aftermarket cams).

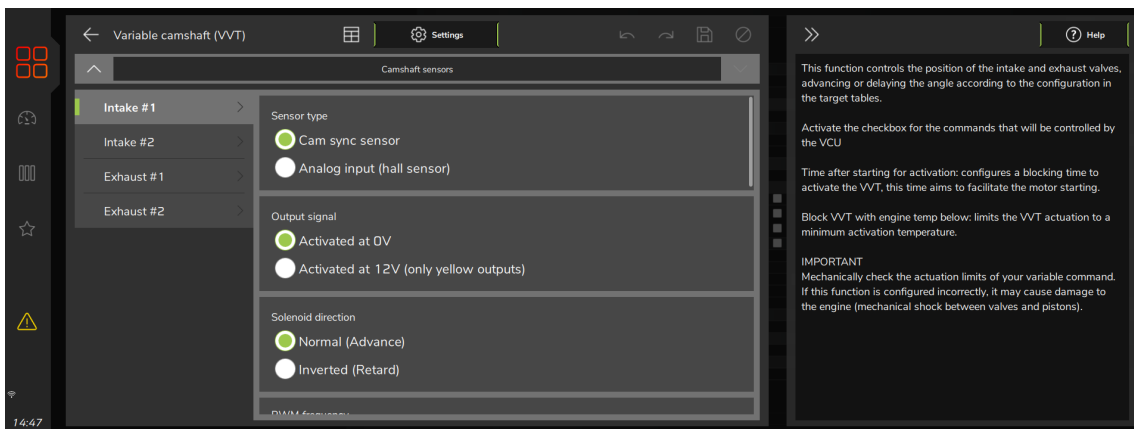
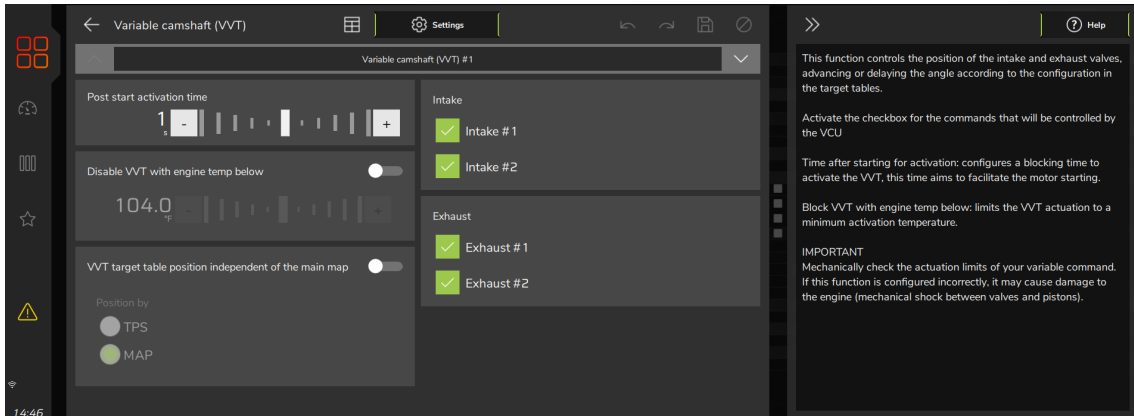

**Intake and Exhaust target:** The table will be created according to the settings for the main fuel table, so it can be either RPM x MAP or RPM x TPS. The values used here are in degrees in relation to the cam sync sensor position angle.

**Example:** If the sensor position angle is at 45°, and there is a value of 10° inserted on the table, the camshaft will be advanced to 55°.



## 20.25 Automatic transmission control

This function is responsible for managing the automatic transmission with up to 10 gears.

Based on the settings of the speed maps and the function, the ECU will automatically trigger the determined gear and has the ability to read and relate the original temperature, pressure and gear speed sensors.

**Gear based compensation minimum time:** Time editable by gear for applying oil pressure compensation when changing gears and operating solenoids that work only when changing gears.

**Range selector 1, 2, 3 & 4 mode:** select the operation mode.

- **Limit gear up to the selected position:** If this option is selected, the transmission will change gears up until the last selected gear. For example: selecting “3” in a 4 speed transmission, it will change gears only from first to third gear.
- **Hold gear in the selected position:** In this option, the transmission will be locked in the selected gear and won't perform gear shifts. For example: selecting “3”, it will be only in third gear, regardless of the condition.

**2-step line pressure control:** Percentage of transmission oil pressure during the 2-step. When this function is enabled, during 2-step, the percentage of oil pressure will correspond only to the value set in this cell, discarding the value set in the table “Transmission oil pressure”.

**Rejection time between up and down shifts:** Set the lockout time after gear shifts.

**Gear change delay during throttle pedaling:** This setting prevents the transmission from changing multiple gears when the accelerator is pedaled. It is possible to activate the solenoids between gear changes, this configuration is necessary for the correct control of some gearboxes.

### ! IMPORTANT

*In order to the ECU identify correctly gear change, it is necessary to enable Gear Change Detection option (Map Options menu) and configure it as By Automatic transmission control.*

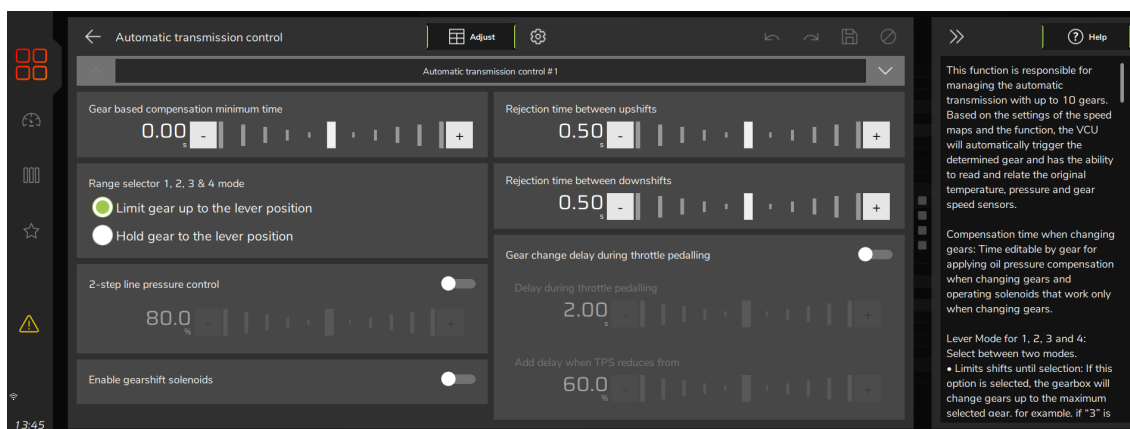

**Maximum RPM for gear shifting:** When the engine RPM is higher than this value, the controller won't allow the transmission to perform gear shifts. This function avoids transmission mechanical failures.

**Minimum speed at each gear:** Minimum speed for the entry of each gear, if the vehicle speed is lower than the one configured in this table, the gear will not be changed regardless of the “Gear shift table” table. This option is used as currency protection.

This feature has a 1.2mph hysteresis to validate gear reduction.

**Maximum speed to downshift at each gear:** Maximum speed so that during a reduction the gear does not enter, avoiding damage to the engine / gear unit. This option is used to protect the mechanical transmission system.

If the vehicle is not downshifting according to the table “Gear change table”, it may be that the “Maximum speed to downshifting at each gear” settings are configured inappropriately for the gear ratios and desired operation.

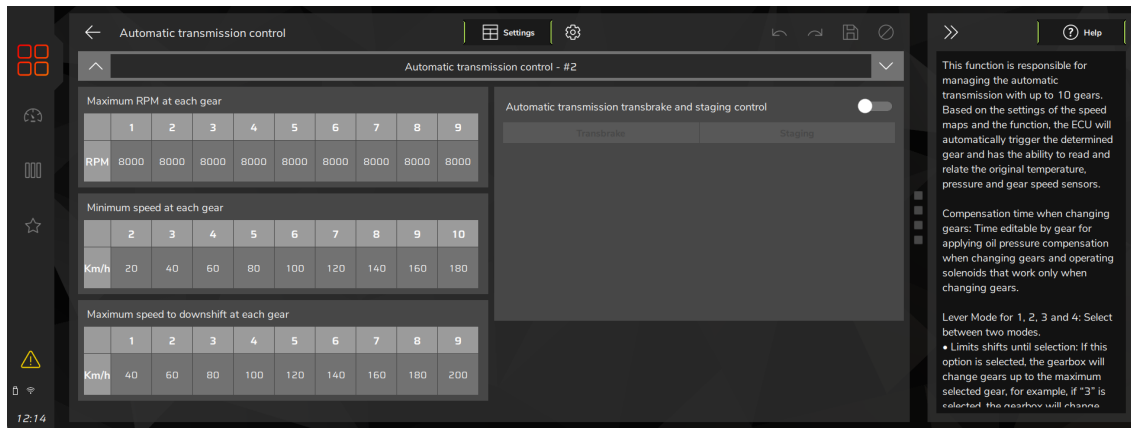

## Tables

**Upshift:** In this tab, select the solenoids that will be activated to increment each gear.

**Downshift:** In this tab, the solenoids to be activated during gear reduction must be selected. In most of the cases, both tables will be the same. The solenoids shown in this menu are directly related to their selection in the “Solenoids” section, if they are not enabled they will not be available in the Drives Map menu.

**Gear change table:** In this menu, gear changes are configured based on the accelerator position (TPS) and wheel speed. Blue numbers on the left side of the table represent upshift, while the red numbers are downshifts.

It is recommended to keep the downshift speed lower than the upshift. The number of gears shown in this option can be changed by accessing the Sensors and Calibration, Gear detection menu.

**Gearbox line pressure table:** In this menu, the PWM values of the transmission oil pressure solenoid are configured in relation to the gear and the accelerator pedal position (TPS), normally the higher the PWM value, the lower the transmission oil pressure. If the transmission is slipping, it may be necessary to decrease the PWM value in this condition in order to increase the transmission oil pressure. Depending on the way the solenoid was connected, the table can work in an increasing or decreasing way to increase the oil pressure.

**Line pressure by temperature compensation:** Set the PWM correction related to the transmission oil temperature, usually is necessary to decrease the PWM value when temperature goes high (in order to increase the oil pressure and compensate the drop due to the rising temperature).

To have this feature working right, it is necessary to have “Transmission temperature” sensor configured in the Sensors and Calibration, Inputs menu.

**Gear change line pressure compensation:** PWM compensation for oil pressure gear change. To have smoother gear shifts, a decrease in oil pressure is usually necessary during the shift. This can be done in this table by increasing the PWM for each condition.

In general, the increase in PWM causes the transmission pressure to be reduced, which ends up smoothing the gear shift.

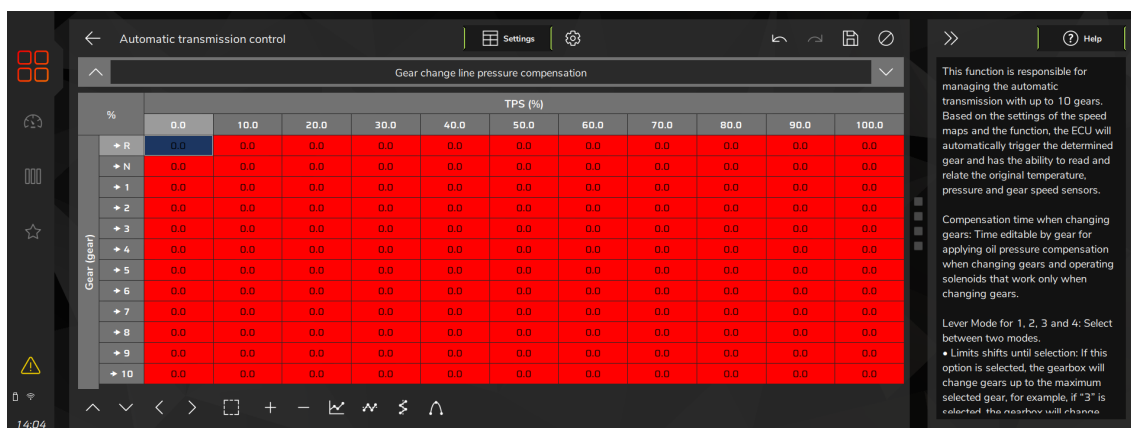

**Solenoids:** In this menu, you must select which solenoids will be used in your transmission. The solenoids A, B, C, D, E, F, G and H are the solenoids for gear change.

For example, 4-speed transmissions usually have 2 shift solenoids, than selecting solenoid A and B only.

The Line pressure solenoid is the solenoid that controls the transmission oil pressure.

The Accumulator Solenoid is the solenoid that has an electric oil accumulator that is activated during gear shift to compensate oil pressure difference from one gear to another or even during upshift/downshift.

It is possible to activate them with 0V or 12V depending on the electrical connection of the transmission, change the frequency of activation of the solenoids and make an activation ramp and smooth the oil pressure entry during the activation of the system.

## WARNING

*It is not recommended to use frequencies above 1kHz (1000 Hz) when activating the solenoids, this can cause excessive heating of the actuator and the output goes into protection strategy.*

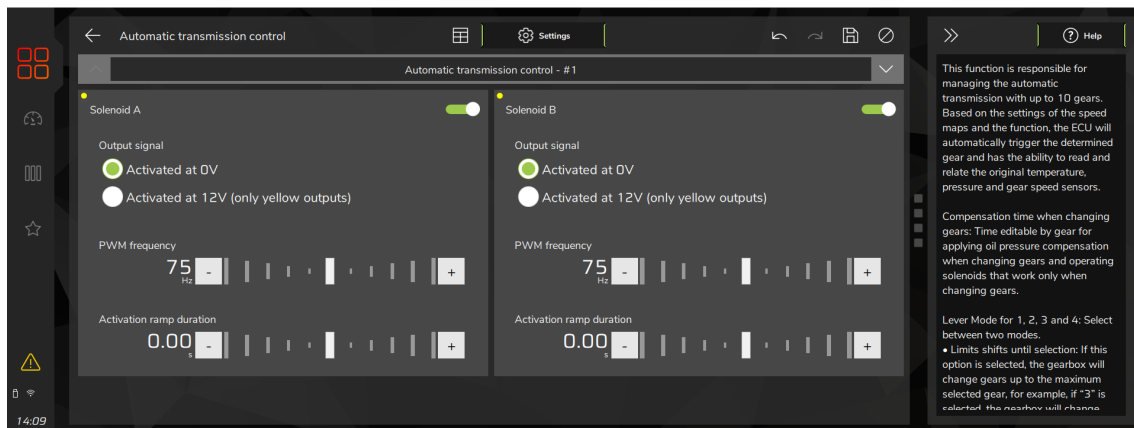

## 20.26 Lockup Control

The Lockup system prevents the torque converter from slipping, which can be activated by an electronically controlled valve in different situations. It is possible to activate the valve in several ways and enable exchange safety protections related to the Lockup system. The security options can also disable the Lockup function, if there is no engine temperature or transmission temperature sensor, the Lockup will not be activated.

**Minimum duty cycle:** Minimum solenoid work WM for cases that require partial Lockup, limiting the minimum opening of the valve.

**Maximum Duty Cycle:** Maximum solenoid duty PWM for applications that need to limit the maximum opening of the Lockup solenoid.

**Activation ramp duration:** Progressive activation time of the solenoid, varying the opening from the minimum to the maximum percentage with configurable time.

**Deactivation ramp duration:** Time for progressively deactivating the solenoid, varying the opening from the maximum to the minimum percentage with configurable time.

**Minimum gear for lockup:** This setting limits the lowest gear that the Lockup will act, regardless of the activation table.

**Minimum engine temperature for lockup:** Minimum motor temperature for activating the lockup, it allows isolating the Lockup operation when the motor is cold to let the converter slip more.

**Minimum transmission oil temperature for lockup:** Minimum transmission oil temperature for lockup activation, allowing the transmission oil to reach its working temperature more quickly.

**Force lockup with transmission temperature above:** Minimum temperature for the lockup to be activated directly, thus reducing the heating of the transmission oil, or forcing the activation of the Lockup to cool the oil in situations of high demand on the system.

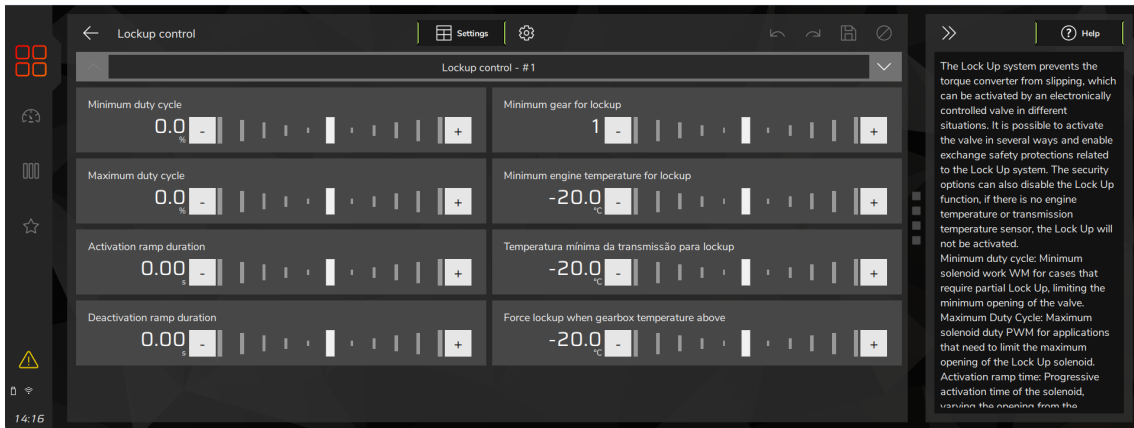

**Disable lockup during Upshift:** Time when the lockup is off during the upshift, smoothing the entry of the next gear.

**Disable lockup during Downshift:** Time when the lockup is off during downshifting, smoothing the entry of the lower gear.

**Disable lockup with brake applied below:** Minimum RPM for the lockup to remain on with the brake applied, allowing greater motor brake.

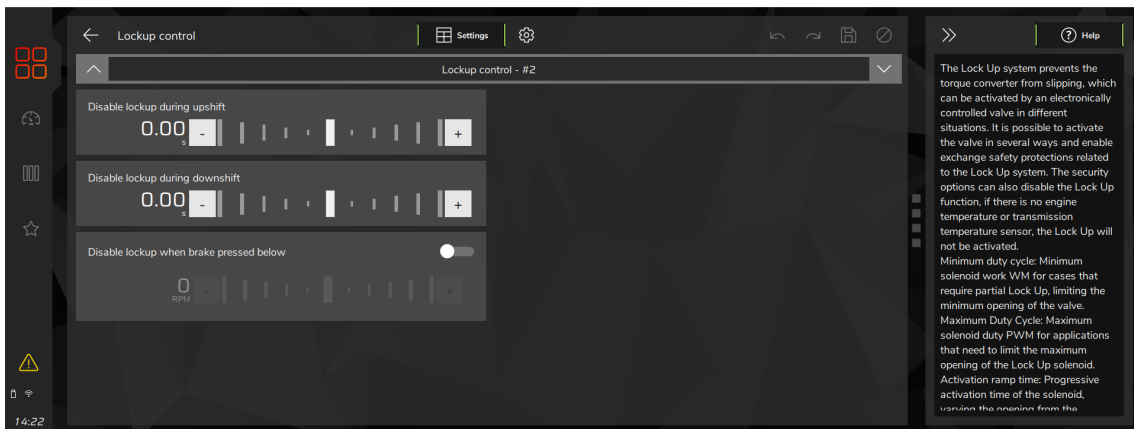

**Lockup Table:** In this table Lockup and Unlock speeds are configured for each gear based on wheel speed and TPS. The lockup will activate above the speed set in “Lockup” and will shut down below the speed set in “Unlock”, between these numbers the ECU will keep the actual state of the output until it reaches the next condition.

Km/h	TPS (%)										
	0.0	10.0	20.0	30.0	40.0	50.0	60.0	70.0	80.0	90.0	100.0
1 lockup	0	0	0	0	0	0	0	0	0	0	0
1 unlock	0	0	0	0	0	0	0	0	0	0	0
2 lockup	0	0	0	0	0	0	0	0	0	0	0
2 unlock	0	0	0	0	0	0	0	0	0	0	0
3 lockup	0	0	0	0	0	0	0	0	0	0	0
3 unlock	0	0	0	0	0	0	0	0	0	0	0
4 lockup	0	0	0	0	0	0	0	0	0	0	0
4 unlock	0	0	0	0	0	0	0	0	0	0	0
5 lockup	0	0	0	0	0	0	0	0	0	0	0
5 unlock	0	0	0	0	0	0	0	0	0	0	0
6 lockup	0	0	0	0	0	0	0	0	0	0	0
6 unlock	0	0	0	0	0	0	0	0	0	0	0

**Output:** Among the options for activating the Lock Up output, there is the possibility of connecting a 12V post-switch power supply to one pole of the solenoid and a FuelTech output to the other pin, activating it at 0V. Another option is to provide constant 0V and drive the output with 12V.

**PWM frequency:** Working frequency of the shifter Lockup solenoid to allow a more gradual activation ramp.

## WARNING

*It is not recommended to use frequencies above 1kHz (1000 Hz) when activating the solenoids, as this may cause the actuator to overheat and the output to go into protection mode.*

## 20.27 Push to pass (P2P)

Function that changes the maximum electronic throttle opening instantly when pressing the P2P button (push to pass). Required P2P button configured in Sensors and Calibration menu, Inputs.

**Throttle maximum opening:** set the maximum throttle opening in this menu (P2P button activated) and set default throttle opening (P2P button disabled) under Engine settings, Pedal / Throttle menu, Throttle opening limit.

**Boost offset:** Sets the pressure value added when activating the function.

**Minimum RPM and Speed:** Adjusts the minimum RPM and speed values for activating the function.

**Pre-push interval:** Time after pressing the button for the function to start.

**Activation time:** Sets a minimum time for the function to activate after pressing the button.

**Interval between activations:** Time from pressing the button to activating the function.

**Maximum duration time:** set the default throttle opening in this menu (P2P button activated) and configure the maximum throttle opening (P2P button disabled) under Engine settings, Pedal / Throttle menu, Throttle opening limit.

It is also possible to define a maximum P2P activation time until another button signal. The maximum configurable time is 30s.

The activation of the P2P Button can be done through an analog input, with option of 0V or 12V activation. Another option is to use a SwitchPanel over CAN network.

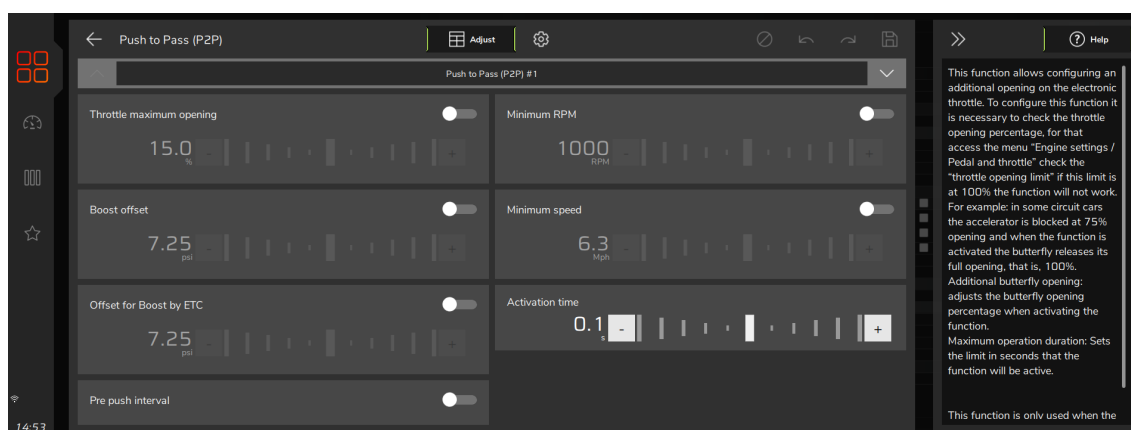

## 20.28 DRS

DRS function on the vehicle's rear wing to reduce aerodynamic drag on straightaways.

**Activation Time:** The amount of time the system takes to activate after the function is activated.

**Activation Window:** Sets the time period during which the function can be activated.

**Maximum Duration time:** Adjusts the maximum time the function will be active.

**TPS / RPM / Minimum Speed:** Adjusts the conditions for the function to be activated.

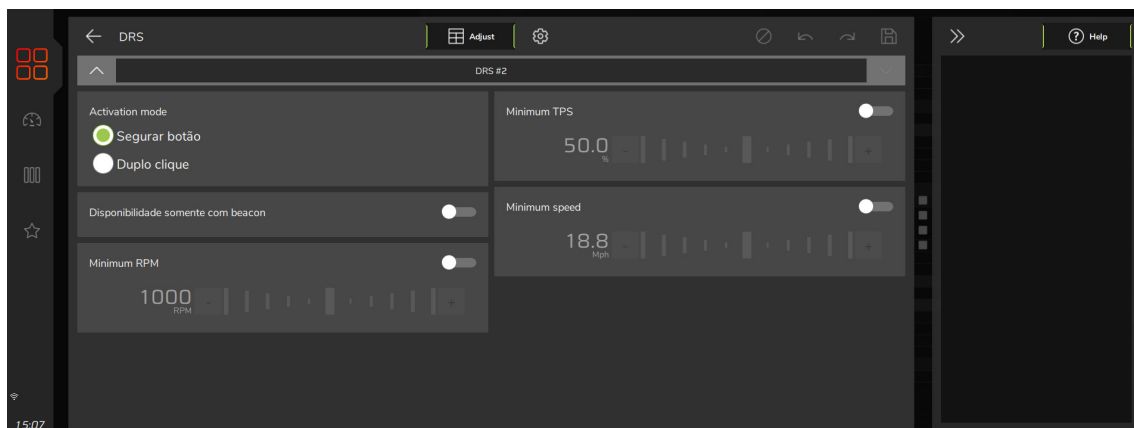
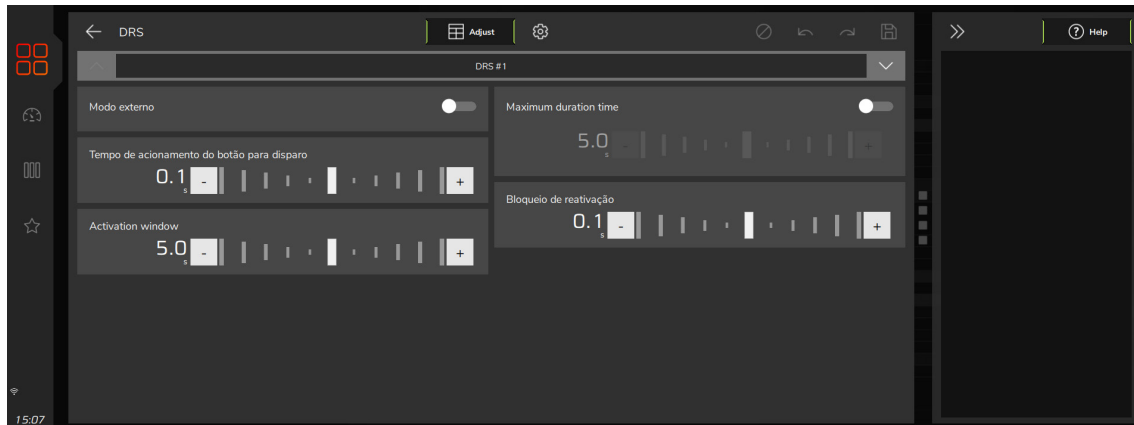

## 20.29 DRL

This function allows you to create different light indication configurations for each vehicle condition. There are three possible modes: DRS Mode, Rain Mode, Push to Pass Mode, Engine ON and OFF Mode. For all cases, you must configure the Duty Cycle Percentage for each color.

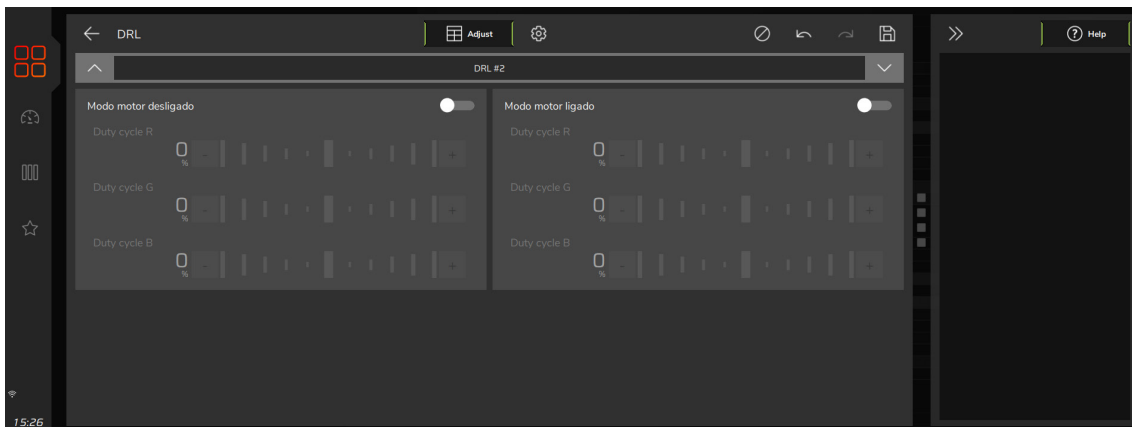
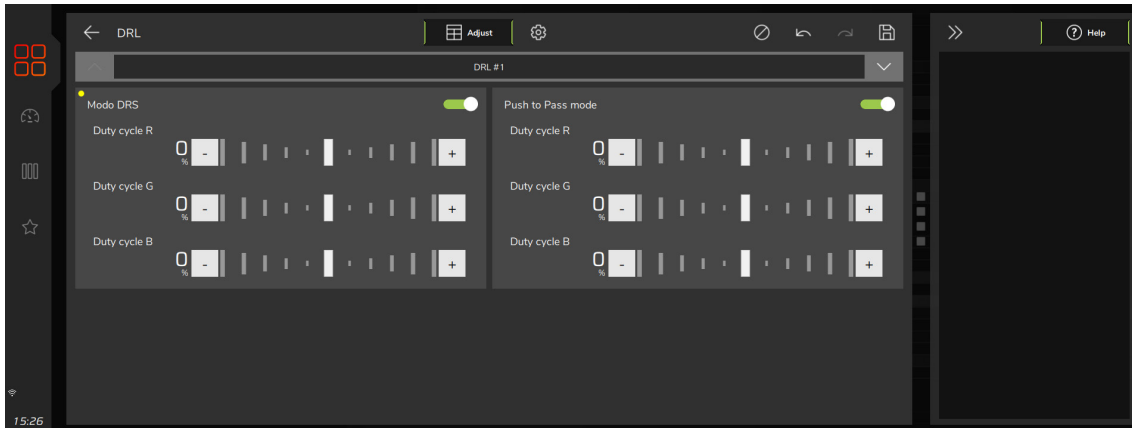

## 20.30 Fan Push

This function provides two more Push to Pass activations. The function configuration is exactly the same as the Push to Pass function.

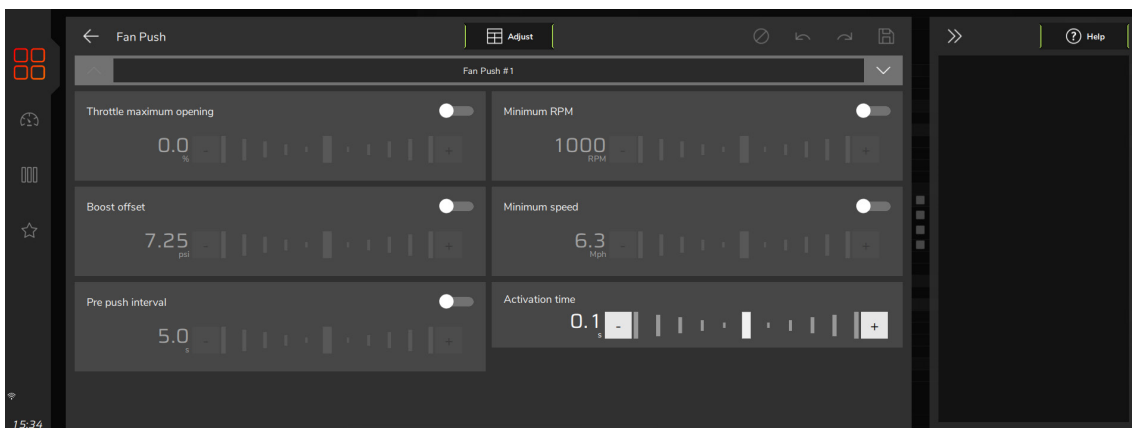

## 20.31 Anti-lag / Pops & Bangs / Engine brake

The Anti-lag / Pops & Bangs / Engine brake function allows different configurations to have some sort of engine effects under certain situations. All settings in this menu are independent of main fuel and ignition tables, and it is possible to configure an external button or a dashboard button to enable the function at any time.

### WARNING

*For correct operation, it is mandatory to have the TPS sensor configured and calibrated under Sensors and Calibration, Inputs menu.*

**Anti-lag:** mainly used on turbo engines, where during a deceleration, the turbine must keep boost and when back to throttle again the engine has all the boost available. To have this effect, in general, it is required to retard ignition timing a lot, have enough air intake in the intake (suggested using an electronic throttle, or some valve that adds air at the intake using the Anti-lag auxiliary output) and ignition cut to prevent the RPM from going up and pushing the car forward. Fuel enrichment will depend on each situation. Anti-lag RPM must match engine and turbine configuration to generate turbo pressure.

**Pops & Bangs:** function to generate small pops, bangs and crackles sounds in the exhaust system, often occurring shots and flames coming out of the exhaust. Configurations as fuel, ignition timing and cut, and throttle or idle actuator opening are directly responsible for the intensity of the effects, as well as the exhaust temperature itself.

It is recommended to use the ignition timing close to 0°, or a little retarded, enough enrichment to have stock AFR, ignition cut above 40% and slight opening of the idle actuator and throttle blade to have stronger effects.

**Engine brake:** option to adjust engine brake according to the motor. Especially recommended for motorcycles that have very strong engine brake and may lock traction wheel under hard decelerations. Adjustments related to electronic throttle opening, idle actuator or activation of the Anti-lag auxiliary output allow the engine to smooth power transfer in a given deceleration, and gear based air adder is the best option to configure it. It is also possible to have some ignition cut or negative fuel enrichment for better adjustment.

Possible to configure function activation with an external button that can be operated as a switch or button, option to activate it by 0V or 12V, choice to start the ECU with the control ON or OFF, option for Anti-lag auxiliary output activation mode and conditions to have the function operating, such as brake and clutch pedal validation, maximum TPS, minimum RPM, activation delay, activation ramp that allows a smoother progression for fuel, ignition and throttle or idle actuator compensations.

**Enable function by:** there are three modes, Always on, external button and on-screen button

**External button activation mode:** configure how the external button will be activated

**Start VCU with:** selects whether the function will turn on together with the VCU.

**Brake switch activation:** Configure whether the function will be activated when the brake pedal is pressed or released. For this configuration it is necessary to have a switch installed on the brake pedal.

**Clutch switch activation:** Configure whether the function will be activated when the clutch pedal is pressed or released. For this configuration it is necessary to have a key installed in the clutch pedal.

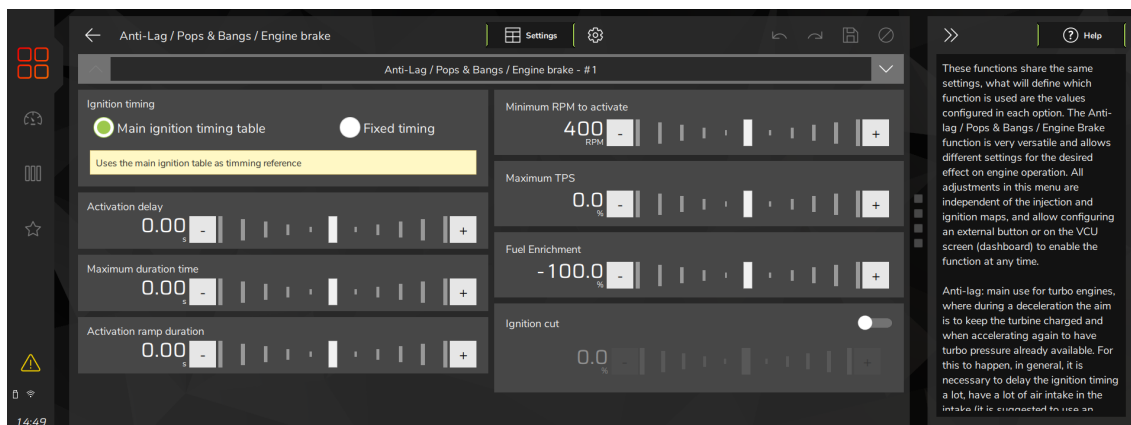

**Ignition timing:** select where the function will look for the ignition timing to activate the function.

- **Main map:** uses the point table from the main map
- **Fixed point:** sets a fixed ignition point.

**Activation delay:** adjusts the delay value for starting the function.

**Maximum duration time:** defines a maximum time for the function to operate.

**Activation Ramp Duration:** Sets a ramp for the function to switch on and off more smoothly.

**Minimum RPM to activate:** sets an RPM value to trigger.

**Maximum TPS:** configures a TPS value for the function to be activated.

**Fuel enrichment:** defines how much fuel will be added or removed when activating the function

**Ignition cut:** Adjust the percentage of ignition cut that the function will work.

**Idle actuator / Electronic throttle:** define the form of control by fixed value or by table per gear.

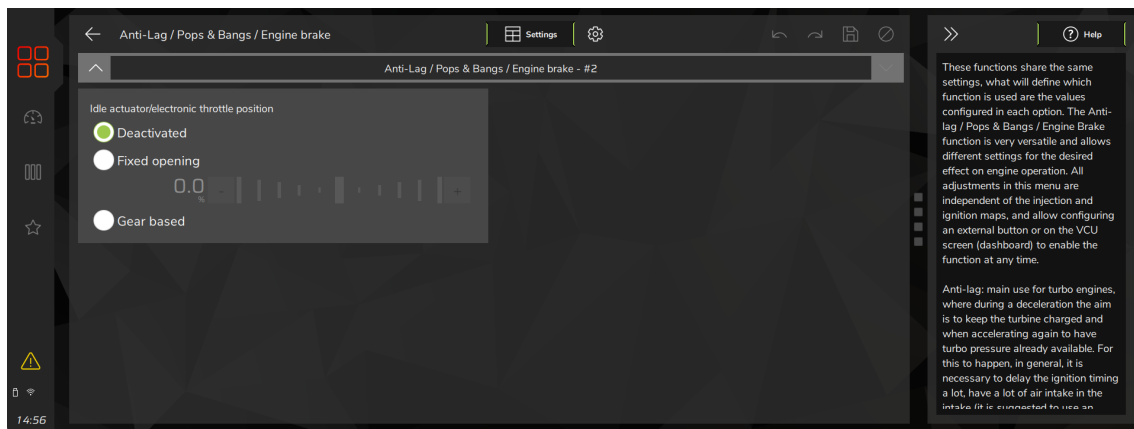
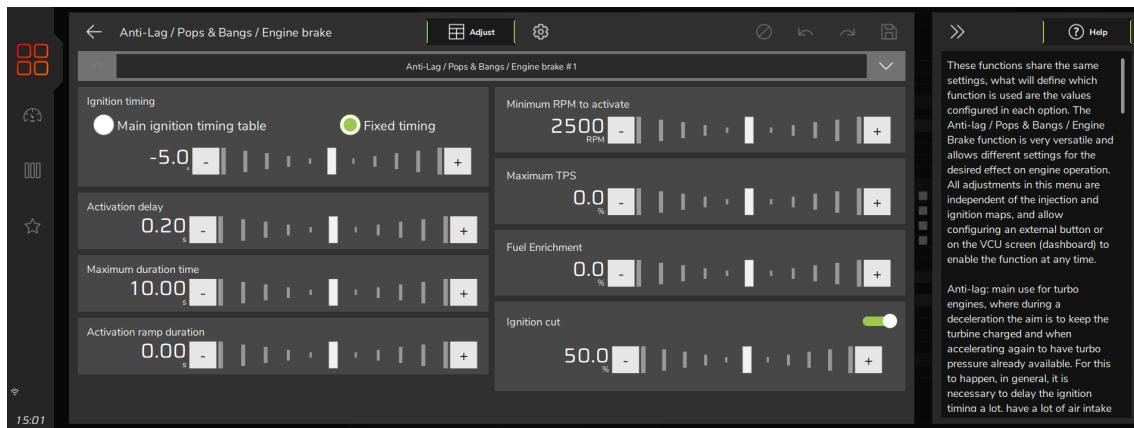

## 20.32 Gear control Management

Function developed to control sequential transmission for road race cars, with logic for paddle shift activation, barrel position sensor, activation of electric or pneumatic solenoids for gear shifting, fuel injection and ignition cuts for power reduction, blip for better gear shifting and safety protections. Recommended use with the Compressed air control function for pneumatic systems.

**Gear shift command options:** There are three possibilities of gearshift control, through a paddle shift on the steering wheel or automatic by RPM, together with the automatic shift function or even through an external TCU connected via CAN Network (FTCAN 2.0).

- **Manual paddle shift and automatic by RPM:** recommended for sequential transmissions
- **External gearbox control:** allows synchronization with the automatic transmission control function, for cases in which the transmission model used is not sequential
- **FTCAN 2.0 (external TCU):** allows synchronization with data via CAN network when available

**Lock time between gear shift:** Adjust the time in which the function will be blocked to perform the next cut for engaging the next gear.

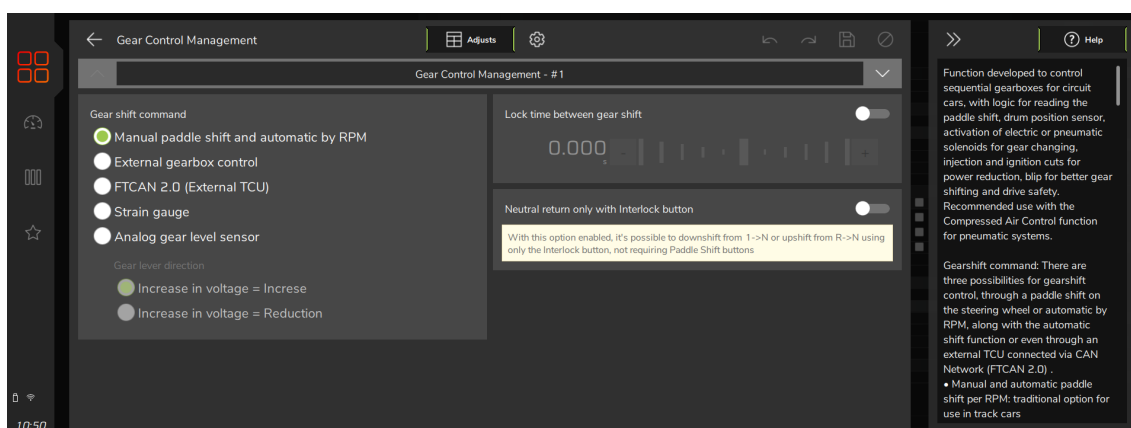

## Upshift

**Automatic gear shift by engine RPM:** option that will automatically upshift when the engine RPM is increasing and reaches the set value for each gear, only dependent on the RPM value

**Power reduction:** fuel injection / ignition cut during upshift, with the option for the ignition timing applied to the engine during the ignition cut to be the same as the main ignition table or a fixed timing determined in the table, as well as the ignition cut percentage.

The duration of the power reduction configured in the table is the maximum value that will be applied. To decrease cut time, you can enable the option to activate closed loop power reduction after the next gear is detected, so when detecting that the next gear has been engaged, the ignition cut will be interrupted.

Enable Upshift solenoid output to activate the pneumatic solenoid or electric motor for gear change, with the option to choose the output voltage when using the yellow ECU output.

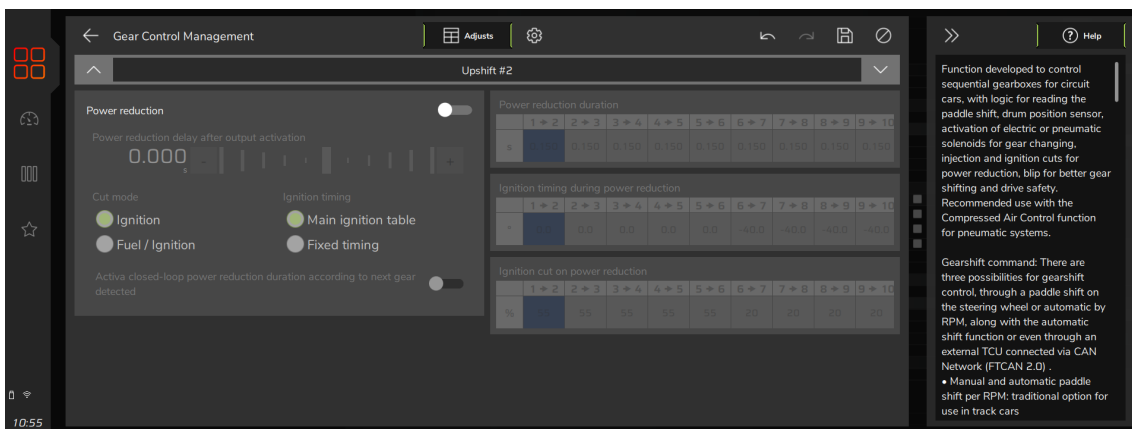
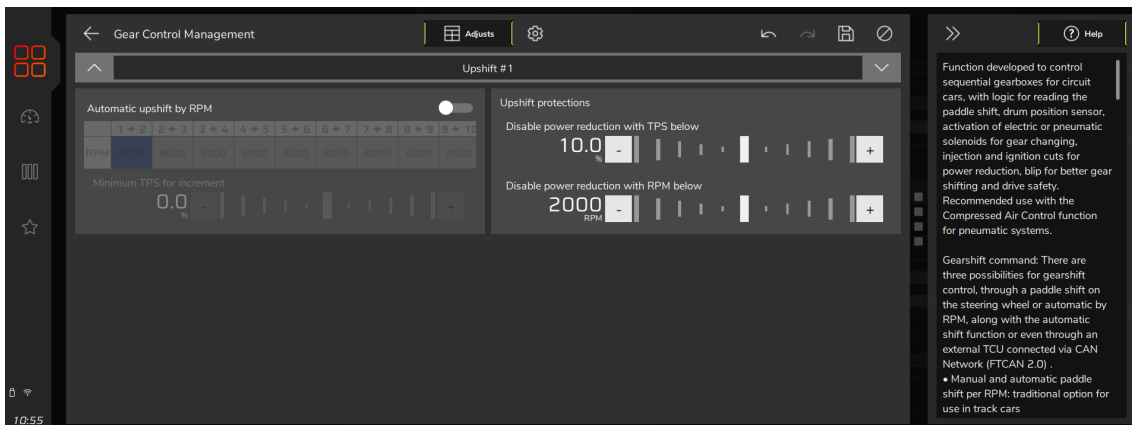

## Downshift

**Automatic gear change by engine RPM:** option that will automatically downshift when the engine RPM is falling and reaches the value set for each gear, only dependent on the RPM value

**Power reduction:** fuel injection / ignition cut during downshift, with the option for the ignition timing applied to the engine during the ignition cut to be the same as the main ignition table or a fixed timing determined in the table, as well as the percentage of ignition cut.

The duration of the power reduction configured in the table is the maximum value that will be applied. For downshifts, this value will only help the gear disengage the current gear, so a short time can be used, and the use of the closed loop power reduction duration is not recommended.

Throttle percentage added on downshift: blip in the electronic throttle with additional percentage and maximum acceleration time to allow the disengagement of the current gear.

### Downshift protections:

Maximum RPM protection for downshifting, thus preventing that when the previous gear is engaged, the engine does not pass the maximum safe RPM for operation.

Option to reject downshift with TPS above a certain percentage, preventing the previous gear from being engaged with the engine under load.

Option to disable power reduction with TPS below a certain percentage, for cases where the previous gear can be engaged without power reduction without load.

Enable Downshift solenoid output for pneumatic solenoid or electric motor for gear change, with the option to choose the output voltage when using the yellow ECU output.

Additional power reduction after gearshift: option that after the lower gear is engaged, the car is not pushed forward, since the throttle has been requested and a gear has been reduced. The ignition cut will decrease the engine's strength.

**Stacked downshift:** option for the ECU to consider gear change requests even when safety parameters are not met, when it is safe, the ECU will automatically reduce the requested gears, within the conditions stipulated in that option.

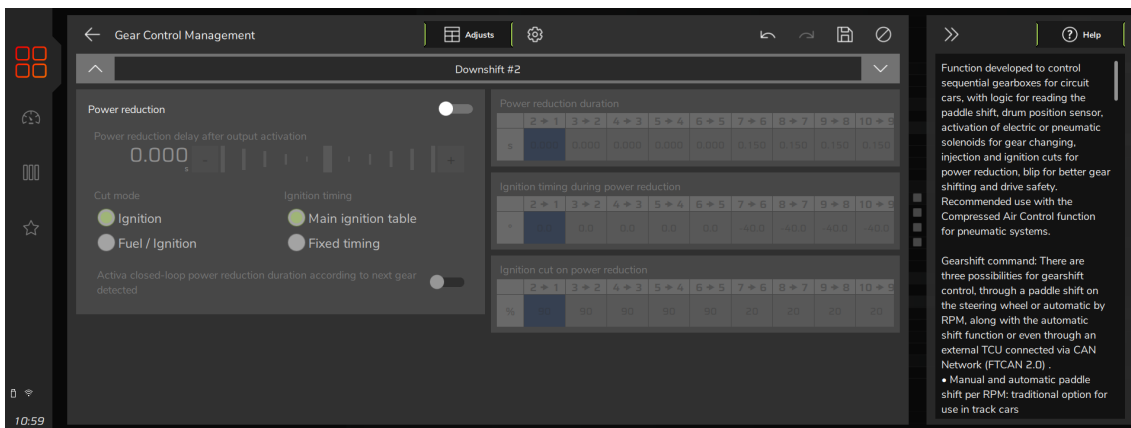
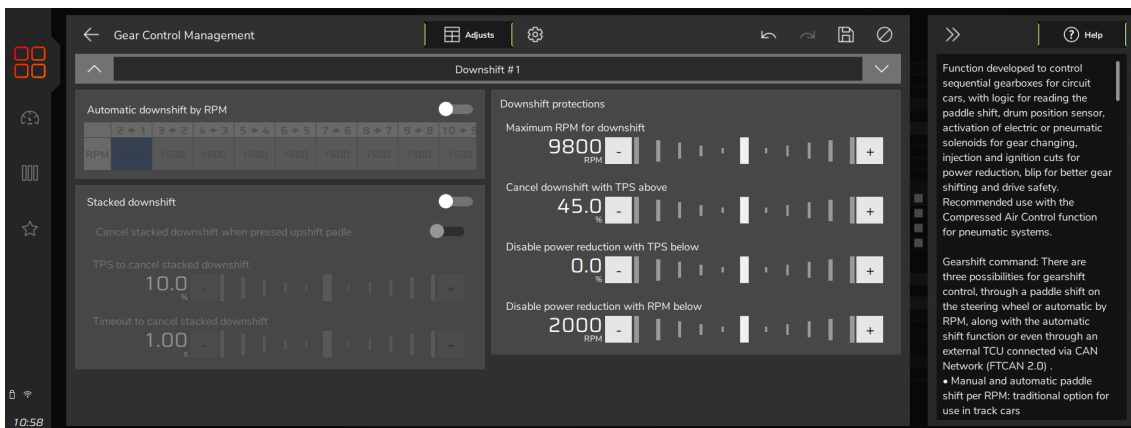

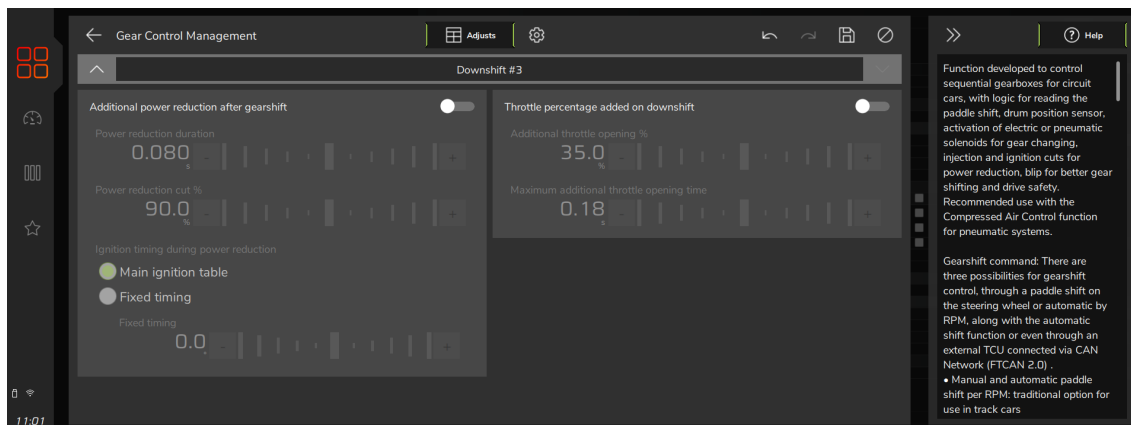

## WARNING

When the ECU is requested to apply more than one type of ignition cut from different functions simultaneously, the cut with the highest % configured will have priority, so the function with the lowest % of cut might not operate as expected.

### Gear shift sequence:

N > 1: Interlock + Paddle Up button

N > R: Interlock + Paddle Down button

1 > N: Interlock + Paddle Down button

R > N: Interlock + Paddle Up button

For general gear shifts only Paddle Up and Paddle Down are required.

### Necessary inputs for operation, configure in the Inputs menu:

- Upshift button
- Downshift button
- Gear position sensor (Analog)
- Interlock button (Safety button)

### Outputs required for operation, configure in the Outputs menu:

- GCM: Upshift solenoid output
- GCM: Downshift solenoid output

### 20.33 Compressed air control

The control is based on the pressure limits, a pressure reading below the minimum will activate the compressor and keep it on until the sensor reaches the higher pressure configured.

**Operating mode:** select whether the compressor can always be activated or only with the engine running.

**Turn ON below:** adjust the minimum pressure for the compressor to be activated

**Turn OFF when reach:** adjust the compressor shutdown pressure.

**Minimum and maximum times:** Minimum time for compressor ON and minimum time for compressor OFF have priority over the pressure values, meaning that if the minimum time ON is longer than necessary to reach the maximum pressure, the compressor will continue to operate, as well as if the pressure drops to a value lower than pressure to turn ON and the minimum time OFF is not met the compressor will remain unactivated.

To eliminate the control time, set 0s on both settings. If the sensor is disconnected, the compressor will follow the minimum time ON and minimum time OFF.

Possibility to configure output activation mode, and it's mandatory to configure the Air compressor pressure (Sensors and Calibration menu, Inputs) and the Air compressor output (Sensors and Calibration menu, Outputs) for correct operation.

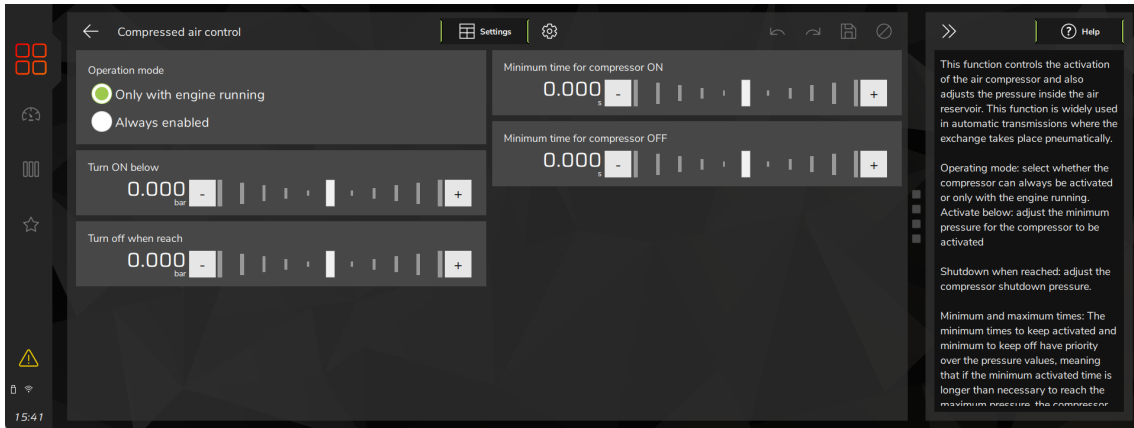

### 20.34 Electronic wastegate control

The control allows different configurations to control the boost pressure, such as one or two electronic wastegates external to the exhaust manifold, or integrated electronic wastegates (original factory turbocharged car models) and even the throttle control present in some supercharger engines known as blower by-pass.

**Control type:** The function allows different types of control to meet the most varied applications. As it is a closed-loop control system, the pressure value defined in the tables will be the target that the control will work to maintain, and the pressure is read by the MAP sensor in FuelTech itself or with an external MAP sensor.

**Actuator configuration:** select type and quantity of eGates

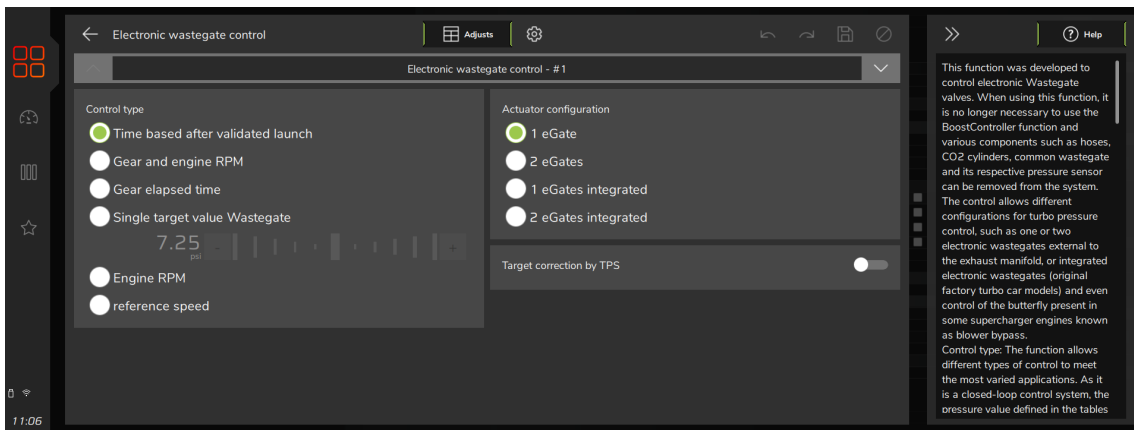

**Launch targets:** It is possible to configure pressure targets for different occasions such as 2-step, 3-step, Burnout, launch (for time control types but in use outside drag conditions such as 2-step, 3-step Burnout), being independent targets of other situations.

**Wastegate target pressure overall trim:** You can quickly adjust the target pressure through this setting.

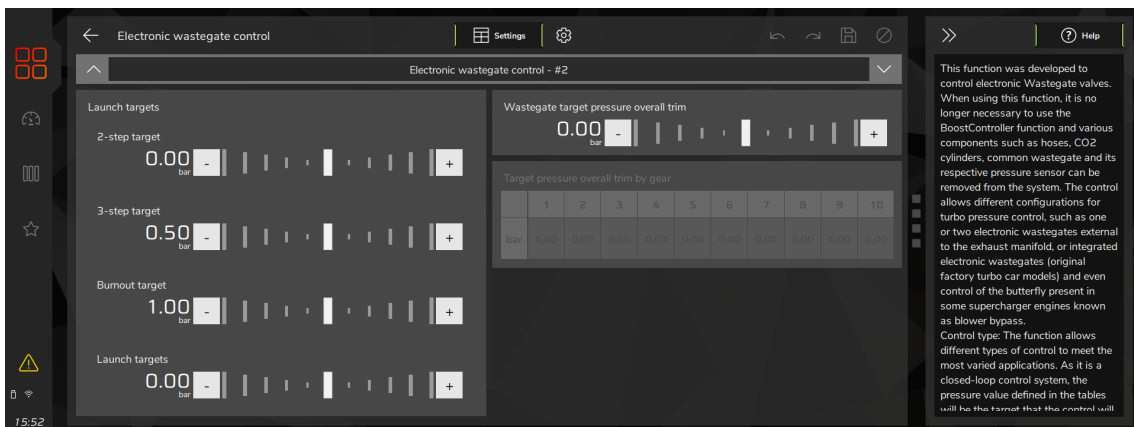

Setup pressure curve for eGate.



**Egate rest position:** Possibility of changing the wastegate position when in rest condition (no load), simply configuring a TPS for which the ECU will maintain the configured position below it, either a fixed value or a table per RPM.

**Egates offset:** difference in positions between the eGates (when using more than one) so that the back pressure in the two exhausts is the same, being a % position value in relation to the position of eGate #1.

**Boost+ button activation mode:** Possibility to use a Boost+ button to add pressure over the pressure target at the moment, the button can be activated by 0V or 12V.

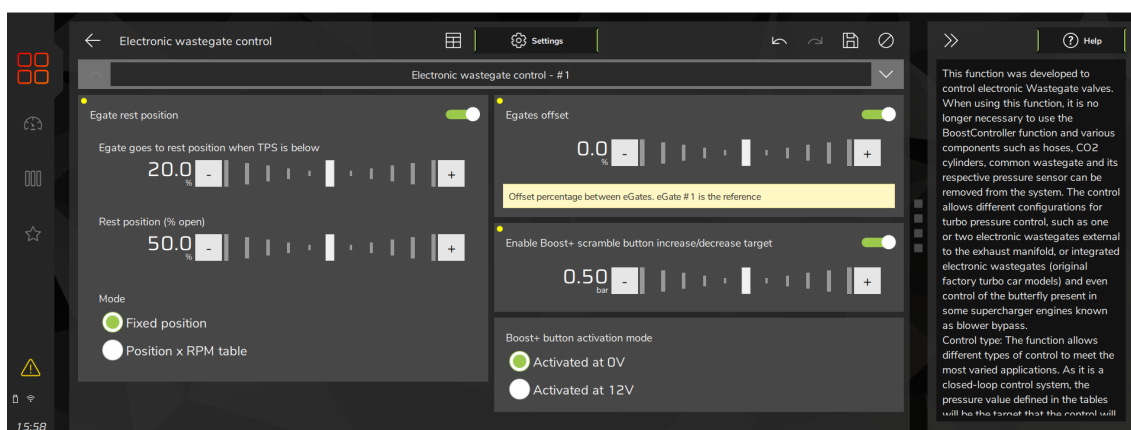

**Target in Anti-lag / Pops&Bangs / Engine brake:** configures the target when activating the functions.

**Integral Anti-windup:** exclusive option of FuelTech's electronic wastegate control, where the control maintains force on the valve so that it remains closed with sealing in the seat, in this way it is possible to load turbo pressure faster and allows to reach higher pressure in extreme conditions.

If you select the anti-windup option with the Electronic Wastegate Control in Preset mode, the virtual spring will be electronically activated from the following conditions: Minimum RPM = 2500RPM / Minimum TPS = 40% / Minimum MAP = 0.00bar. To change these conditions, go to the map's Advanced Options menu, and change the Electronic Wastegate Control mode to Custom.

NOTE: the control always has minimum conditions to activate the virtual spring, they are minimum RPM = 2500RPM, minimum TPS = 40%, minimum MAP = 0.00bar.

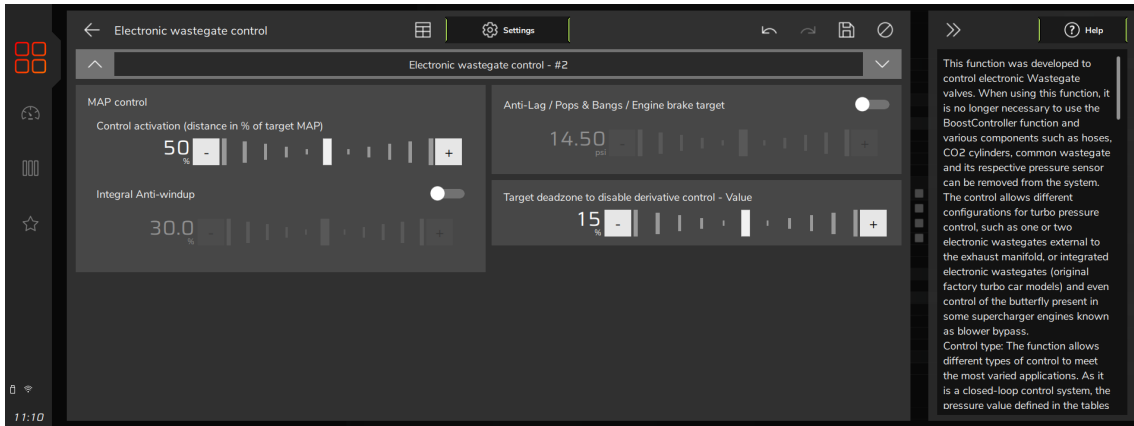

### 20.35 Boost control by ETC position

This function allows to control turbo pressure using the electronic throttle position.

**Control type:** There are two modes: single target or engine RPM.

**Minimum position for activation:** Sets the minimum throttle position for the function to activate.

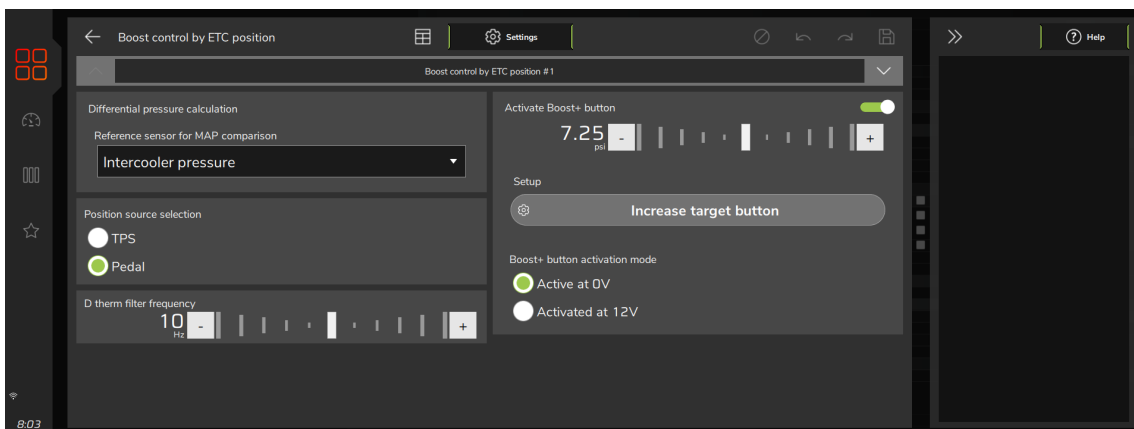
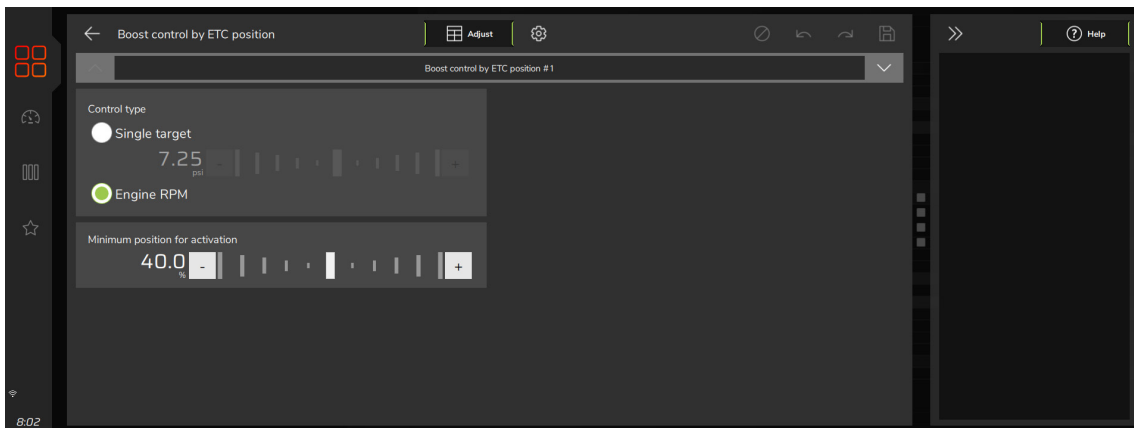

### 20.36 Control by external reference

Control by external reference allows FuelTech to share ignition and electronic throttle management (only models with SENT protocol) with any external control system. The parameters that define the range of change between the controls are RPM, MAP and TPS, and for values below the numbers the control will be in charge of the external source and above the configured values FuelTech will assume the management using the ignition tables and compensations configured in the FT.

In order to share the controls, it is necessary to use the external system ignition signals connected to the white inputs as well as the external throttle signal. Inputs must be configured as Ext. Ignition timing and External throttle body.

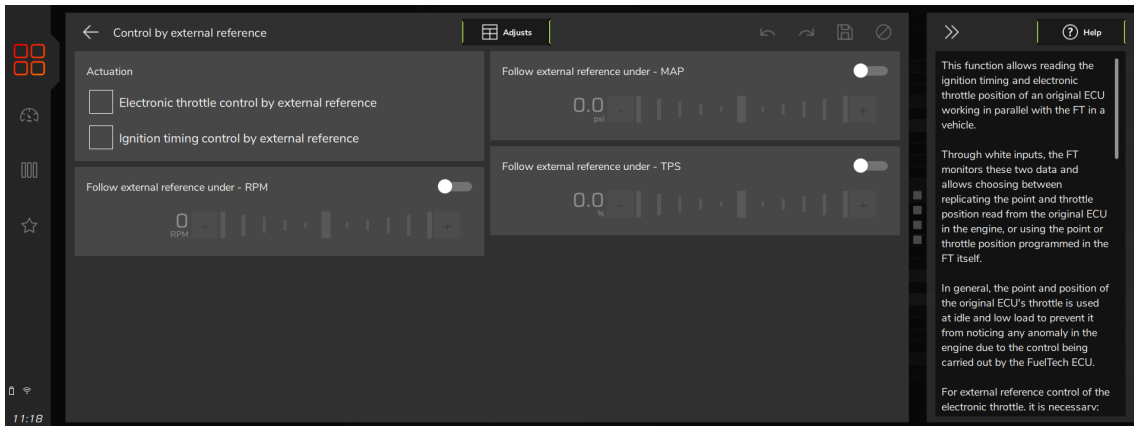

### 20.37 Timed main relay

This function activates a timed output when turning on the ECU to activate a main relay, normally controlled by the original ECU.

**Mode:** Defines the behavior of this output, whether timed, always enabled or only while cranking.

**Activation time:** Sets the activation time in timed mode.

**Output signal:** 0V or 12V (yellow outputs)

**Disable output when pressing “Engine Stop button”:** Disables the output when turning off the engine via the ECU.

**Required outputs:** A blue, gray or yellow output.

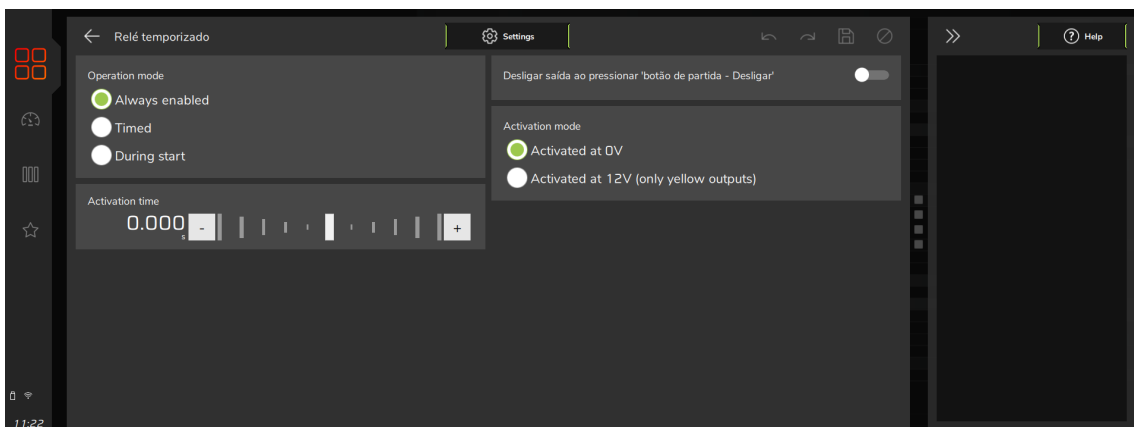

## 20.38 Electronic Blow Off control

This function is dedicated for controlling 2-wire electronic blow-off valves. It is based on the TPS variation to be activated.

**Activate with Delta TPS variation:** Minimum TPS variation rate to activate the valve opening. This variation is negative because it is the closing of the throttle that activates the opening of the valve.

**Deactivate with TPS variation:** Minimum positive variation rate to close the valve again. This variation is positive because it happens with the opening of the throttle.

**Minimum MAP:** Minimum turbo pressure above which valve opening will occur.

**Maximum activation time:** Maximum time that the valve remains open. The valve closes instantly if the TPS reaches the deactivation range, regardless of time.

**Always activate:** This function keeps the valve open in the following conditions: Idle, 2-step and 3-step.

**Output activation mode:** By 0V or 12V (yellow outputs)

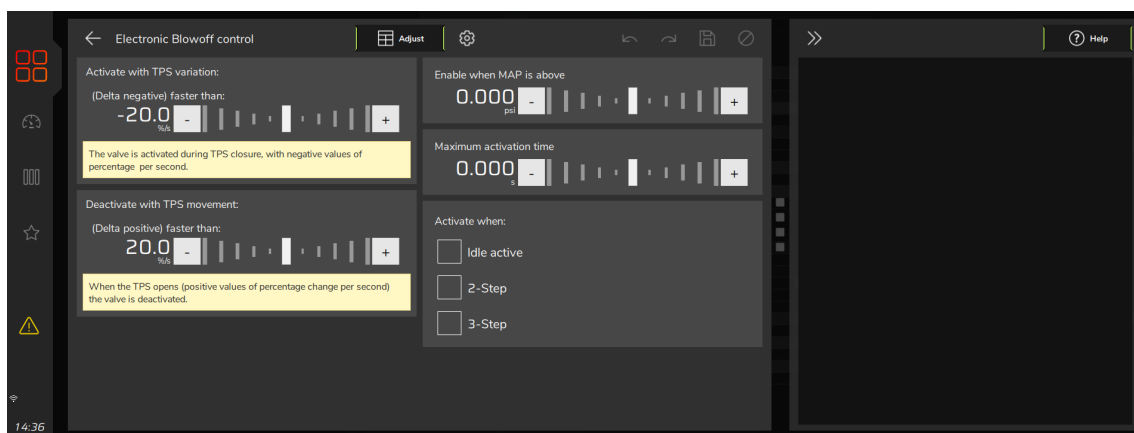

## 20.39 Brake bias

This function allows you to set different pressures for controlling the brakes on the front and rear wheels. To do this, you need to set the number of increment and decrement steps for each stepper motor.



It's necessary to configure two buttons, one for increasing and one for decreasing pressure. To control the stepper motors, it's necessary to use two outputs for each motor.

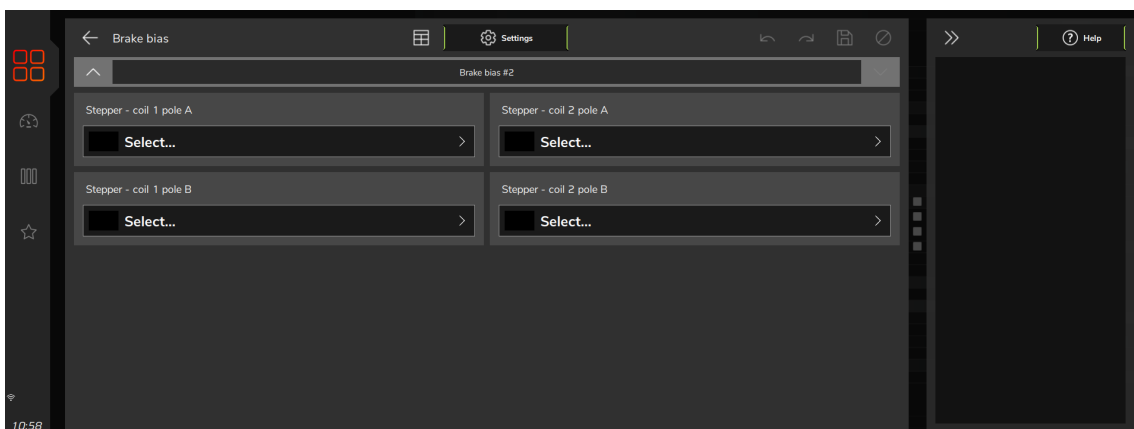
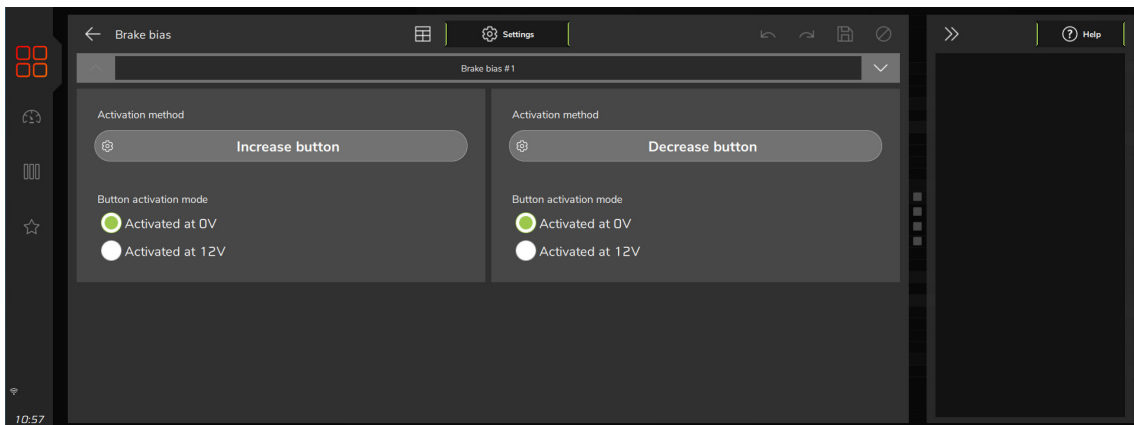



# ***DRAG RACE***

Features



## 21. Drag race features

This menu gathers all options normally used in drag race applications. All the time based features start after releasing the 2-step button which indicates the moment when the vehicle launched.

### 21.1 Burnout mode

The Burnout Mode is a function used to facilitate the processes of warming up the tires and using the two-step. When pressing the two-step button, the two-step function is activated. Once the button is released, the curves from the Time-based RPM Control come to action, allowing the tires to be warmed up properly.

**Always start VCU with:** Choose if burnout mode will be enabled or disabled when turning on the VCU.

**2-Step limiter and RPM limiter on burnout mode:** Setup the final limiter on 2-step.

**Fuel enrichment:** for burnout mode is also independent and configurable.

**Timing:** The timing table for rev launch is used as an alternative to the fixed timing. With the table it is possible to use an timing based on MAP x RPM.

**Turn off burnout mode below:** disable burnout mode when RPM above that value.

There are seven ways of enabling burnout mode: White wire input, CAN, Dashboard, Bluetooth, Ethernet, wifi, smart trigger.

- *Dashboard button:* a button on VCU dashboard;
- *External button:* a common temporary button connected to a White input. A negative pulse on the input enables and/or disables the burnout mode;
- *External switch:* a switch connected to a White input. When the switch is on, it connects the input to ground. For the time the input is connected to ground, the burnout mode will remain enabled. Select an input through the menu “Sensors and Calibrations” then “Inputs”.

There’s also an automatic turn off feature by RPM. When engine RPM goes below the RPM setup here, the burnout mode is automatically disabled. Option not available when “External switch” is selected.

### WARNING

*When the VCU is requested to apply more than one type of ignition cut from different functions simultaneously, the cut with the highest % configured will have priority, so the function with the lowest % of cut might not operate as expected.*

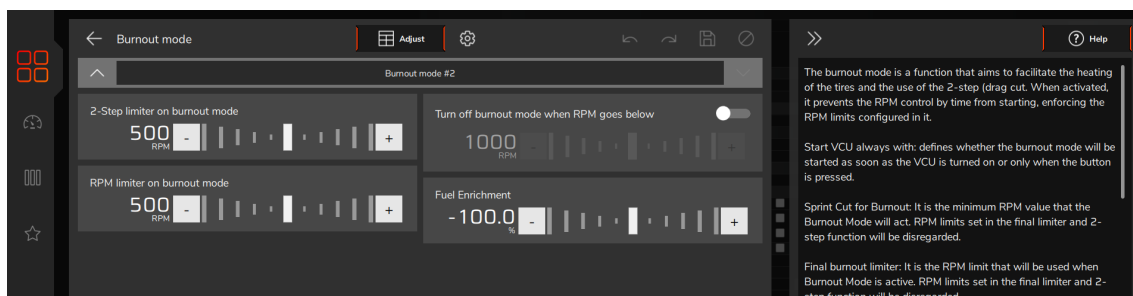
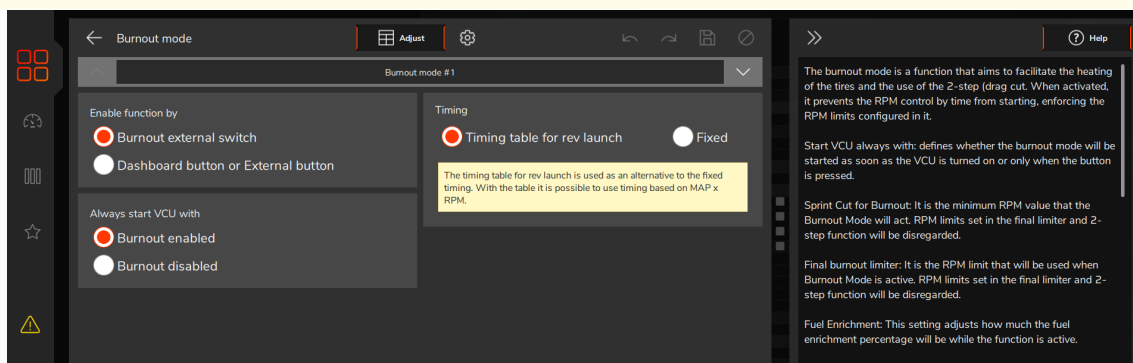

## 21.2 3-step (boost spool)

The 3-step is quite similar to the 2-step function, however, with more aggressive strategies to assist in the boost spool.

**Activation method:** There are two ways to activate this function, one uses an external button (must use a white wire attached to a button, usually on the foot brake) and the other is through 2-step button.

- **3-Step button:** The button can be configured through a white input normally connected to the brake pedal, or a button on the SwitchPanel.
- **Auto ON with 2-Step:** Activates 3-Step in the same way as 2-Step (by button or by speed). As soon as the pressure reaches the configured limit, the 2-Step delay and enrichment values are valid.
- **3-Step enabled until boost:** Sets a target pressure for turning off the 3-Step, that is, when the pressure reaches the configured value, the 3-Step function is deactivated and the 2-step comes into action.

In this case, you must press the 2-step button and the 3-step will be activated until the engine reaches a predefined boost pressure, at this point the 3-step will be deactivated and the 2-step will be activated.

If using an external button to trigger the 3-step, when it is triggered simultaneously with 2-step button, the 2-step will prevail.

The 3-step also validates all time based features, being necessary to press the button with TPS over 50%, or hit the 3-step rev limiter.

**Operation mode:** There are two modes fixed RPM and Roll Start.

- **Fixed RPM:** You can use a fixed RPM for all pressure ranges or use the Ignition Timing map for drag cutting
- **Roll start:** When the 3-Step button is pressed the RPM will be fixed at the current engine, RPM, the TPS can be pressed up to 100% helping to load the turbine for a rolling start.

**Start compensation x RPM before:** RPM value to start fuel and ignition compensation.

**Minimum TPS to activate ignition and fuel compensation:** Sets a percentage value of TPS to initiate point and enrichment offsets.

**Ignition timing:** There are two possible configurations for managing the 3-Step.

- **Timing table for rev launch:** is used as an alternative to the fixed timing. With the table is possible to use an timing based on MAP x RPM
- **Fixed:** Sets a fixed ignition timing for the 3-Step, that is, while the function is active, the timing will remain locked at the configured value.

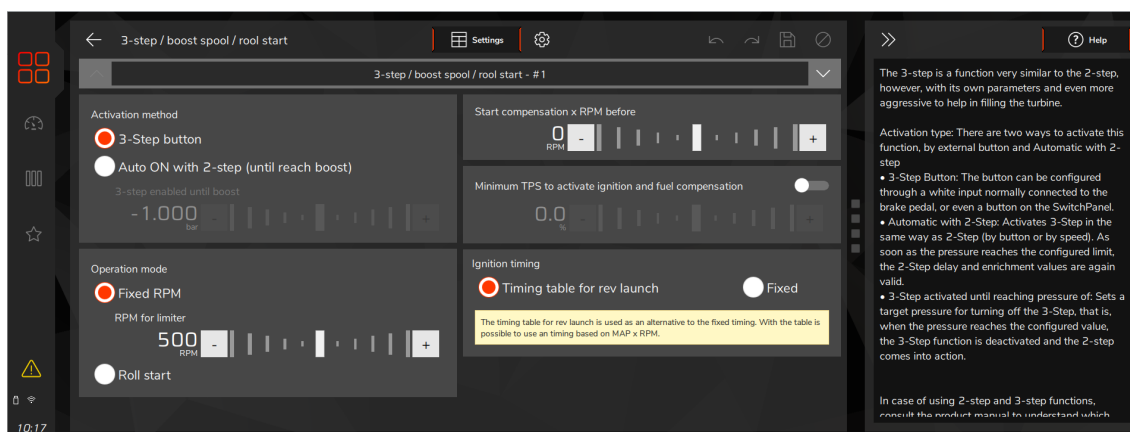

**Fuel enrichment:** Configures the fuel enrichment percentage.

**3-Step rejection after launch:** It is possible to configure two ways of rejection by time and by RPM, this function is very useful in cases where the button is pressed involuntarily during a drag, for example.

- **Rejection duration:** Adjusts the time that the function will be blocked after a valid launch.
- **Rejection when above:** Configures a minimum RPM for the function to be activated again.

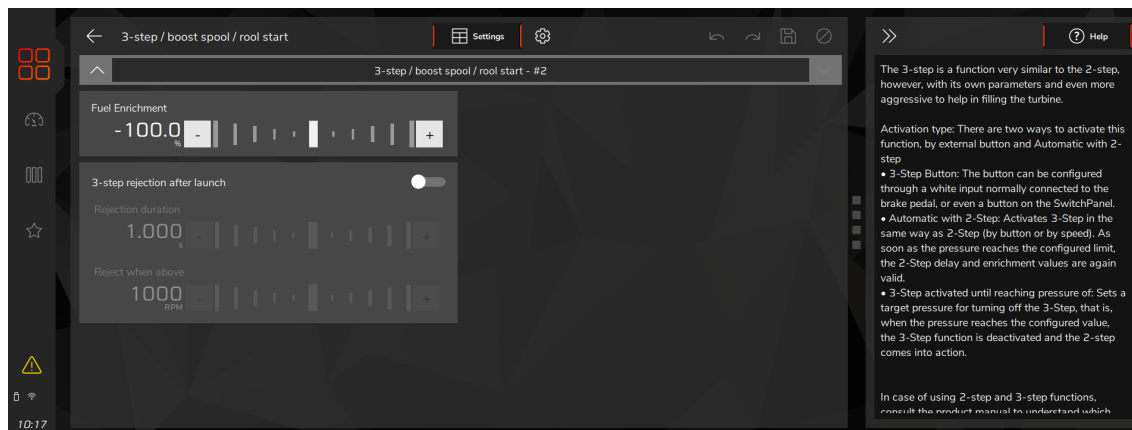

## WARNING

*When the VCU is requested to apply more than one type of ignition cut from different functions simultaneously, the cut with the highest % configured will have priority, so the function with the lowest % of cut might not operate as expected.*

### 3-Step Alert LEDs

**3-step without valid launch condition:** Yellow

**3-step with valid launch condition (ign cut or TPS):** Green

**Invalid launch:** red blinking for 5 seconds

**Valid launch:** LED is turned off (it would be green until a valid launch)

**3-step + Alignment button:** Blue

**Non-3-step alignment button:** Purple

### 21.3 2-step rev limiter

This function activates an ignition cut or ignition retard on a predefined RPM, where you can set a different timing or a fuel enrichment with the objective of assisting in the boost spool to launch.

**Target RPM:** Define the target RPM for the 2-Step limit.

**Control modes for 2-step/burnout and 3-step limiters:** 2-step, burnout and 3-step It is possible to configure how the limiter control, whether by ignition cut or ignition delay, or even an advanced option. The cut is configured by the percentage of ignition pulses that will be cut to hold the engine RPM during the 2-step, in addition to a progression range to gradually increase these cuts. In the delay, the maximum delay that will be applied to the 2-step point is configured, in some cases it is enough to hold the rotation, in other cases it will be necessary to enable the cut as well.

**Ignition retard applied by RPM control on 2-step, burnout and 3-step:** Adjusts the ignition timing delay.

**Start compensation x RPM before:** This parameter is used to start the ignition timing delay and the ignition cut before the desired cut and prevent the rotation from exceeding the desired value.

**Minimum TPS to activate ignition and fuel compensation:** Option allows the racing driver to hold the engine at the cutoff RPM on a launch, but without activating the point delay and fuel enrichment earlier than desired.

**Example:** 2-step limiter configured for 8000RPM: when the engine reaches this RPM, the cut level will progressively increase until reaching the maximum level of 90% at 8200RPM (8000 + 200RPM of the progression range).

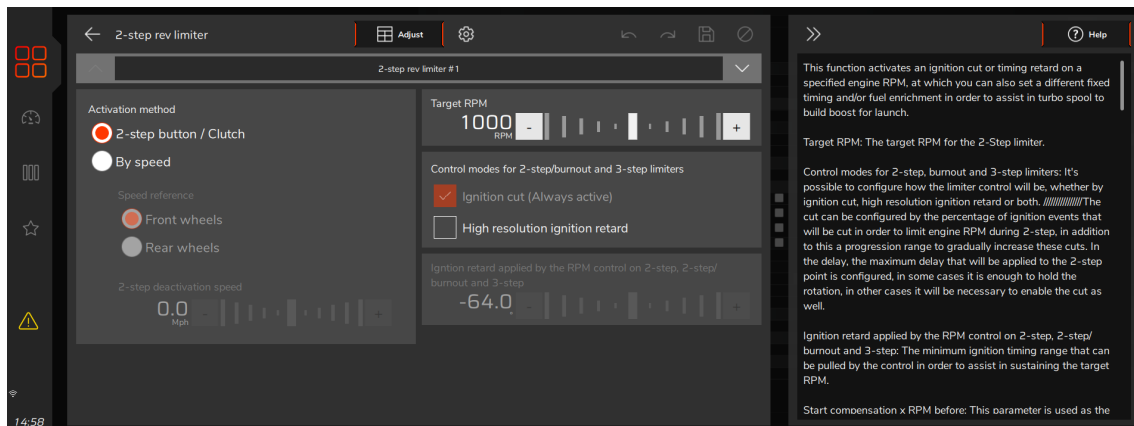

**Ignition timing:** There are two possible configurations for 2-Step.

- **Timing table for rev launch:** Uses the ignition timing values configured in the Ignition Map x Timing table for rev launch.
- **Fixed:** Sets a fixed ignition timing for the 2-step, that is, while the function is active, the point will remain locked at the configured value.

**Maximum throttle opening:** for engines equipped with electronic throttle, it is possible to set the maximum opening of the throttle during the 2-step to have a smoother launch.

**2-step rejection after launch:** blocked an activation of the 2-step after the launch, two safety parameters can be configured. *This lockout must not be used in conjunction with the cut mode performed by the external GearController.*

- **Rejection duration:** Adjusts the time that the function will be rejection after a valid launch.
- **Reject when above:** Adjusts a maximum RPM for rejection the function after valid launch.

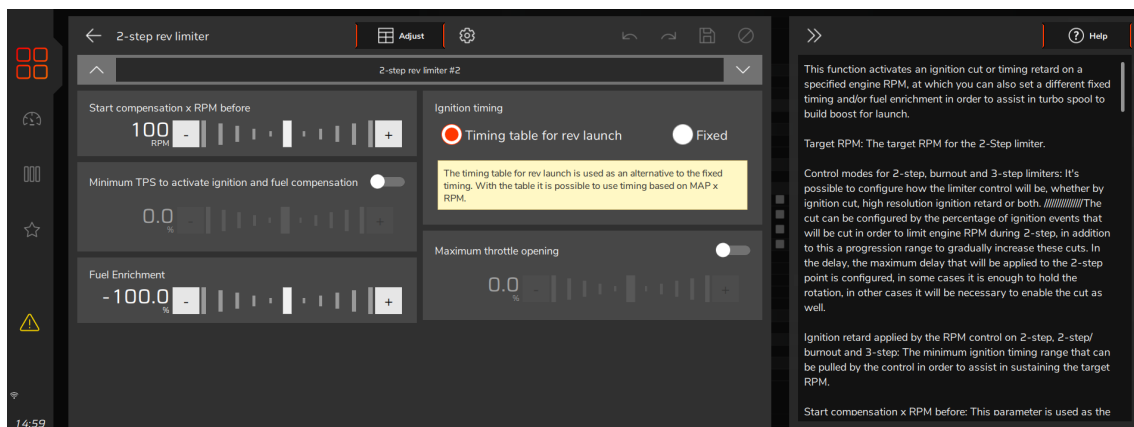

**Ignition cut on 2-step and burnout:** there are two possibilities for setting the 2-step, the Normal mode, which is the default when the map is generated, or the Closed Loop, where FuelTech works the % cut-off of dynamic way to maintain the chosen target, allowing the RPM to be more stable.

**Normal:** Adjusts the ignition cutoff.

Example: rev limiter at 8000rpm, RPM progression range at 200rpm. From 8000rpm the ignition cut level will gradually increase until it reaches 90% cut at 8200rpm.

Percentages less than 90% may not keep the engine under the rev limiter. Bigger RPM progression range tend to stabilize more smoothly the rev limiter, but allows the RPM to pass the RPM set as rev limiter.

These numbers are valid to all kinds of ignition cut, with the exception of time based compensations (time based RPM and driveshaft RPM/wheel speed) and 2-step. These features have their own parameters.

For inductive ignition systems it is recommended to use 90% maximum level and 200 RPM progression range. For capacitive system, like MSD, it is recommended to use 100% maximum level and 1 RPM progression range.

The "Start compensation X RPM before" helps to spool the turbo and have a more stable rev limiter.

The minimum TPS to activate timing retard and fuel enrichment allows the driver to hold the engine in the rev limiter without any compensation when not needed.

The time based compensations will only work after the release of a valid 2-step. This means hold the 2-step button with more than 50% TPS or reach the rev limiter on time at least.

A maximum electronic throttle opening can be set, allowing the driver to launch with the pedal to the floor while the VCU controls the maximum position of the throttle to aid in getting standardized launches.

**Closed loop:** When activating Closed Loop mode it is recommended to disable the high resolution ignition retard, as the two strategies may conflict and make the adjustment difficult. It is also highly recommended to adjust the PI gains under the same RPM and load conditions (TPS and MAP) as the engine will be in pre-launch.

**Proportional Gain (KP):** This generates the part of the ignition cut relative to the difference between the target RPM and the current RPM. This RPM error will be multiplied by the KP Gain and will then compose part of the total cut applied. The specific value generated by KP gain can be identified in the datalogger as “Cut - 2 Step (Proportional Factor)”. Increasing the KP allows the control to react as quickly as possible, but too high KP gains will make the control unstable. When the current RPM is perfectly equal to the target RPM during the 2-Step, the cut percent generated by the KP will be zero, indicating that there is no error. At that moment the KP will be important only to react to load variations or engine response in order to keep the RPM stable.

Default setting value: 0.050, should be increased in small steps and it's not recommended exceeding 0.250.

**Integral Gain (KI):** This generates the portion of the ignition cut coming from the integral of the past applied percentage factor. It can be referred to as “long term” as it stores and calculates an average of what has been applied and what needs to be applied in order to reach the RPM target.

High KI numbers will make the control faster, however high values can cause RPM fluctuations. If this happens it is necessary to decrease the KI. It is very important to analyze the KI performance after a few seconds under 2-step control and have it keeping a stable cut percentage with the least possible oscillations.

Default setting value: 0.080, should be increased in small steps and it's not recommended exceeding 0.320.

Both KP and KI factors have a relationship, so they should not be adjusted individually. In most cases it's recommended to proportionally increase both in most cases, because if one is set too high, there is a possibility that one may become unstable while the other one stabilizes.

**Initial percentage of the closed loop integrator:** This allows the KI factor to start acting at a higher value (not starting from 0) which prevents RPM overshooting the target in the first moments of the 2-Step until the control is able to react. This allows the control to quickly stabilize the RPM, without an overshoot around the target RPM when entering the 2-step condition.

This value should be similar to the percentage of final Cut applied in a stable 2-Step. Therefore, if the engine keeps stable with around 60% of ignition cut stable in the 2-step, you can use 60% as an initial value. If you start with less percentage, the RPM can overshoot right at the beginning and if you use a larger percentage, it can be too much cut and undershoot the target RPM when entering the cut.

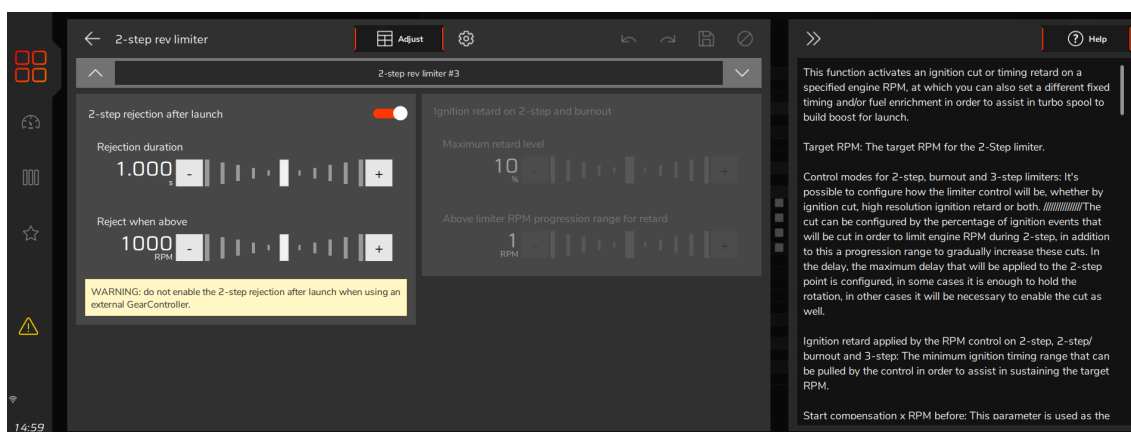

**Activation method:** there are 4 different ways to trigger the 2-step function.

**2-step button / Clutch:** the function can be activated using a button on the steering wheel. Selecting this option, with a button configured as 2-step and another as Clutch button, it's possible to synchronize the two buttons as follows for launch: press the 2-step button on the steering wheel and then press the clutch button when going on gear to stage. At this time, it's possible to release the 2-step button on the steering wheel, ensuring that the 2-step function remains activated only by the clutch button.

This procedure ensures that the 2-step will only be released together with the clutch, not depending on the steering wheel button.

## WARNING

*When the VCU is requested to apply more than one type of ignition cut from different functions simultaneously, the cut with the highest % configured will have priority, so the function with the lowest % of cut might not operate as expected.*

### 2-Step warning LEDs

**2-step without valid launch condition:** Yellow

**2-step with valid launch condition (ign cut or TPS):** Green

**Invalid launch:** Red blinking for 5 seconds

**Valid Launch:** LED is turned off (it would be green until a valid launch)

**2-step + staging control:** Blue

**Staging control button without 2-step:** Purple

**2-Step + 3-Step auto:** White

### Active function tables

The following tables show what will be the active function with the 2-step and 3-step combinations

2-Step: Button	3-Step: Button	Active function
Button 2-step	Button 3-step	Active function
Pressed	Pressed	3-step
Pressed	Released	2-step
Released	Pressed	3-step

2-Step: Sensor	3-Step: Button	Active function
Sensor	Button 3-step	Active function
Active condition	Released	2-step
Active condition	Pressed	3-step
Not Active condition	Pressed	3-step

2-Step: Button	3-Step: Auto	Active function
Button 2-step	MAP pressure	Active function
Pressed	Lower than target	3-step
Pressed	Higher than target	2-step

2-Step: Sensor	3-Step: Auto	Active function
Sensor	Button 3-step	Active function
Active condition	Lower than target	3-step
Active condition	Higher than target	2-step

2-Step: Speed	3-Step: Button	Active function
Speed	Button 3-step	Active function
Lower than target	Released	2-step
Lower than target	Pressed	3-step
Higher than target	Pressed	3-step

2-Step: CAN	3-Step: Button	Active function
Button 2-step CAN	Button 3-step	Active function
Pressed	Pressed	3-step
Pressed	Released	2-step
Released	Pressed	3-step

2-Step: Speed	3-Step: Auto	Active function
Speed	MAP pressure	Active function
Lower than target	Lower than target	3-step
Lower than target	Higher than target	2-step

2-Step: CAN	3-Step: Auto	Active function
Button 2-step CAN	MAP pressure	Active function
Pressed	Lower than target	3-step
Pressed	Higher than target	2-step

## 21.4 Launch delay control (delay box)

This mode only considers delay 1 and/or delay 2 for the final delay calculation. The difference between your dial and a slower opponents dial is NOT considered in the final delay calculation.

**Launch delay 1:** Timer to launch the vehicle that begins counting down upon release of two step button.

**Launch delay 2:** Secondary delay option that allows the driver to get a second hit on the tree by pressing the two step button again after delay 1 timer has been triggered. There are two options: ON (Delay 2 overrides delay 1 and will launch the vehicle based on delay 2 timer once 2 step button is pressed and released for a second time,) or individually: OFF (Delay 2 DOES NOT override delay 1 and the vehicle will launch with the timer of whichever delay expires first.).

**(+) Bump up delay:** Adds a USER defined time to delay 1 in order to calculate final delay timer. The numbers in this field can only have a positive value. *Triggering Bump up multiples times before delay 1 timer expires will result in each instance being added to final delay calculation.*

**(-) Bump down delay:** Subtracts a USER defined time from delay 1 to calculate final delay. The numbers in this field can only have negative values. *Triggering bump down multiple times before delay 1 timer expires will result in each instance being subtracted from final delay calculation.*

**(+/-) Super Bump delay:** ADDS or SUBTRACTS a user defined time to Delay in order to calculate final Throttle Stop Timer. The numbers in this field can have a positive OR Negative value.

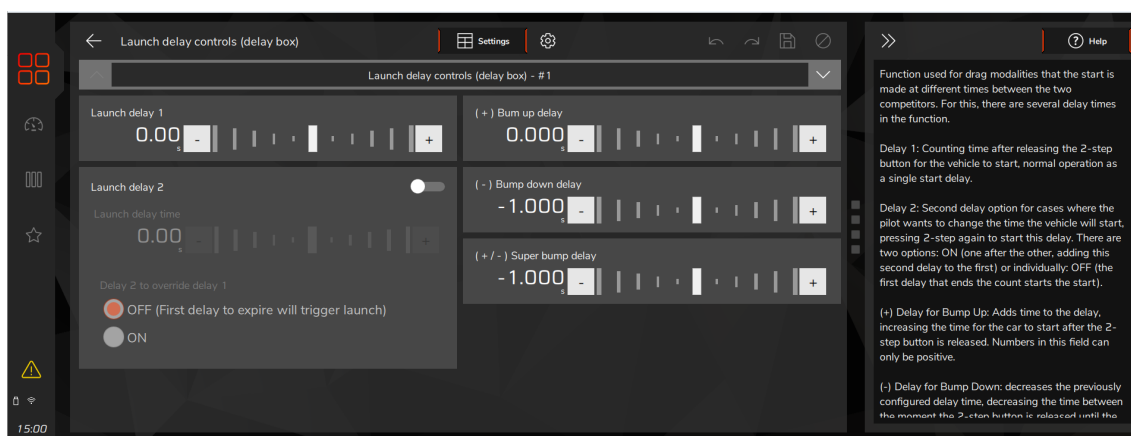

**Pre launch RPM cut:** This feature makes it possible to set a target RPM cut designed to “save” the engine during the staging procedure. The pre launch RPM target will be lower than the 2 step RPM target and will be active while the 2 step button is pressed. It will be active while the two step button is pressed and it will be deactivated when the delay 1 timer reaches the user defined pre launch timer. (Example: 1.000 delay 1 timer and a .800 pre-launch timer will allow the engine to climb to the 2-step target RPM cut when 0.800 remains in the delay 1 countdown)

**ET Dial In:** This parameter will define your dial as well as your opponent's dial to allow the VCU to calculate the crosstalk timer when the opponent is dialed slower than you. This data can be viewed and changed via the instrument panel or on software.

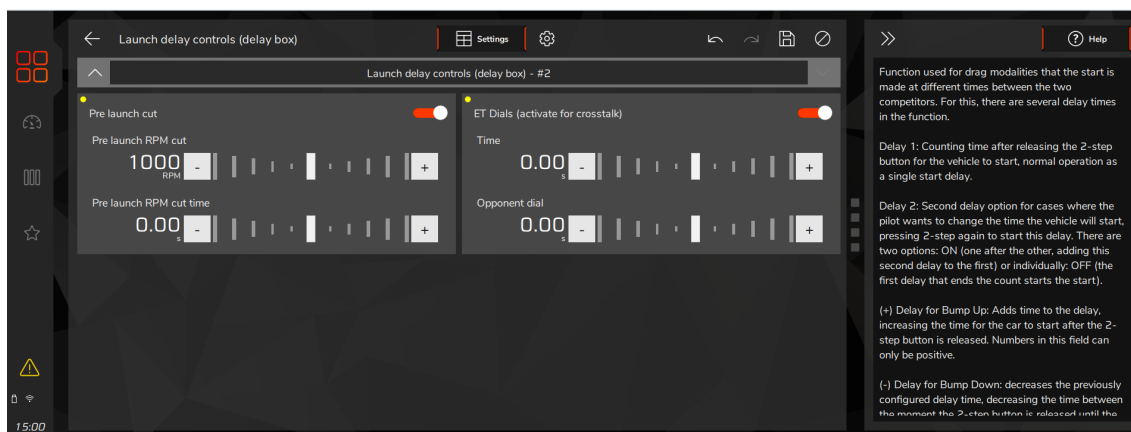

**Inputs:** There are 3 inputs that can be configured. Bump up button, bump down button and super bump button. These buttons can be connected to the analog inputs (white wires) or configured on a SwitchPanel via CAN network.

**Output:** This feature makes it possible to configure an output that will trigger a solenoid to limit the engine air intake opening. This output remains active while two step button is pressed and deactivates when the pre launch timer expires.

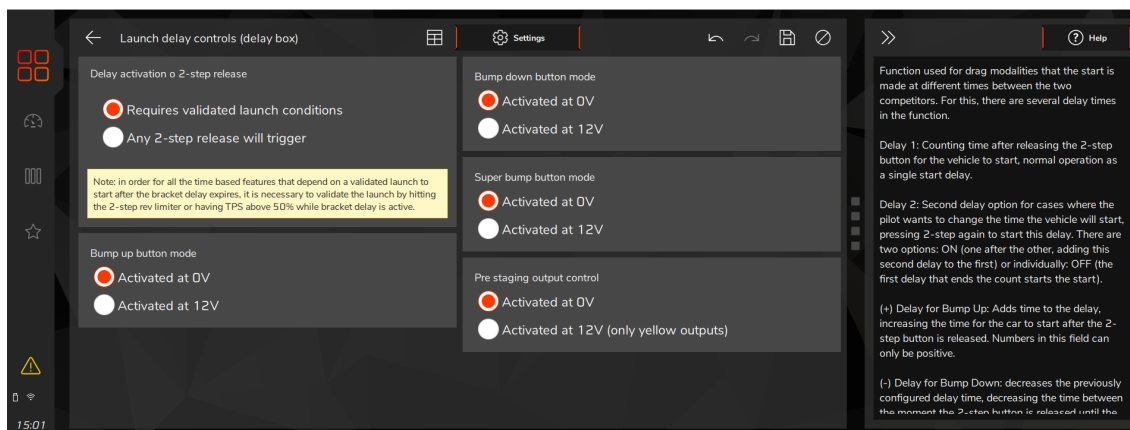

## 21.5 Brake line lock control

This function allows the use of a line lock solenoid to keep the brake line of the trailing wheels pressurized and to facilitate the exit, avoiding that the pilot has to modulate the brake with the foot at the time of the exit.

For correct use of this function press the brake pedal, operate the 2-step, release the brake pedal and the line lock will be activated. When you release the 2-step, the Line Lock solenoid is automatically disabled.

**Activation:** It's possible to have line lock active under undesired situations (Burnout, 3-step, 2-step, Multifunction button). Multifunction button is a single button that under burnout mode can trigger the line lock, under 2-step condition works as staging button and boost+ when not under those conditions.

**OBS:** To have line lock to work with the multifunction button, a driveshaft RPM and front wheel speed input must be set up, and it will only be triggered if both inputs are reading 0mph when the button is pressed. This safety feature will ensure the line lock solenoid won't be activated while the vehicle is moving. An output must be configured as "Output line lock".

**Brake pressure control:** This function enables brake pressure control through a PWM curve. This is used to lower the brake line pressure to a desired value and standardize the launches. It is necessary a white input must be setup as "Brake pressure".

The brake pressure versus PWM must be configured with 100% PWM for all pressures equal or lower than the brake pressure target, gradually diminishing the PWM % with brake pressures above the desired target.

It's recommended to keep a minimum PWM, even for pressures way above the target, avoiding a sudden pressure drop in the brake line. As soon as the 2-step button is released, the linelock will be deactivated.

**OBS:** When using the multifunction button to activate the line lock solenoid during burnout mode, brake pressure control will set the line lock output to 100%.

**Pressure PWM curve:** The pressure and PWM table must be configured with 100% of PWM for all pressures equal to or lower than the starting target, gradually decreasing the PWM with pressures above the target. It is recommended to maintain a minimum PWM, even for pressures well above the target, in order to avoid a sudden drop in linelock pressure. As soon as the 2-step button is released, linelock will be turned off.

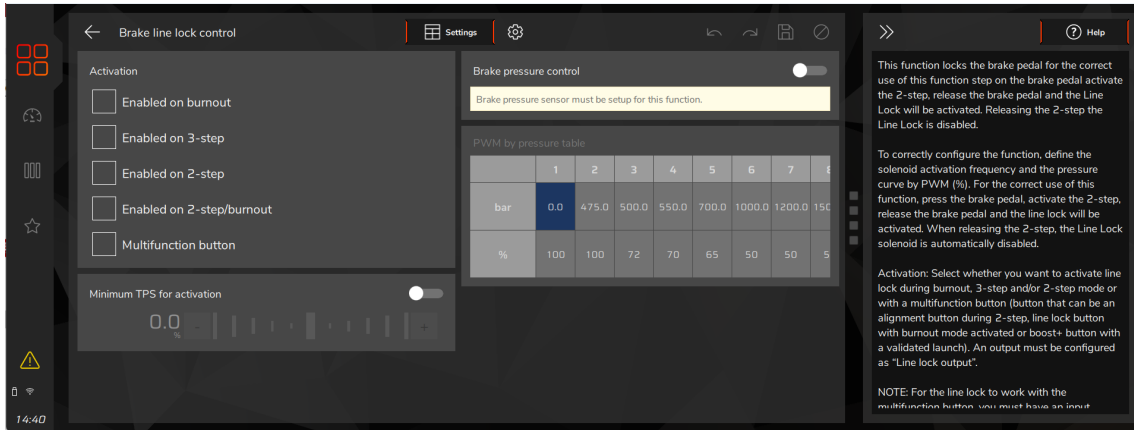

**PWM Frequency:** adjust the operating frequency of the PWM solenoid.

**Output activation:** Configure the output that will trigger the solenoid, 0V (Blue or gray wires) or 12V (yellow wires).

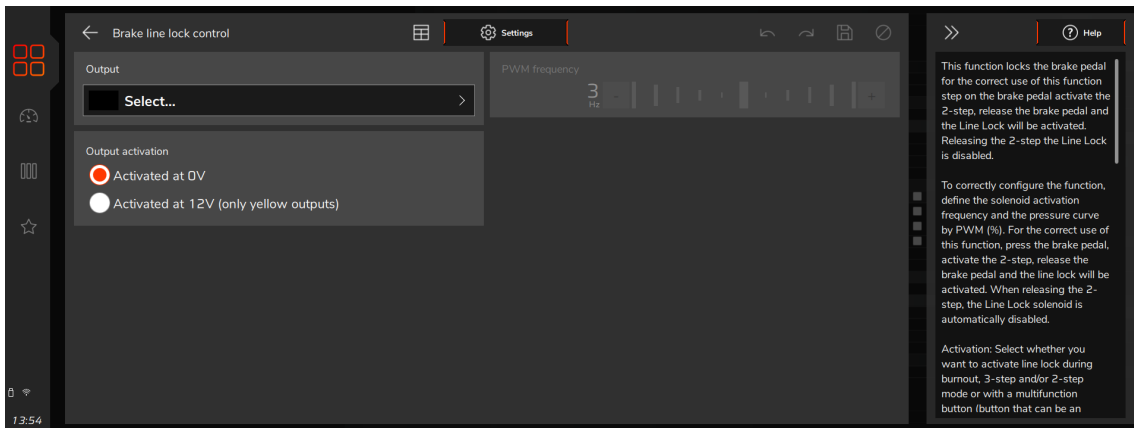

## 21.6 Timing table for rev launch

This timing table is only used for burnout mode, 2-step and 3-step. This is not a compensation table, but a table with absolute timing values, which ignores any other timing table or compensation.

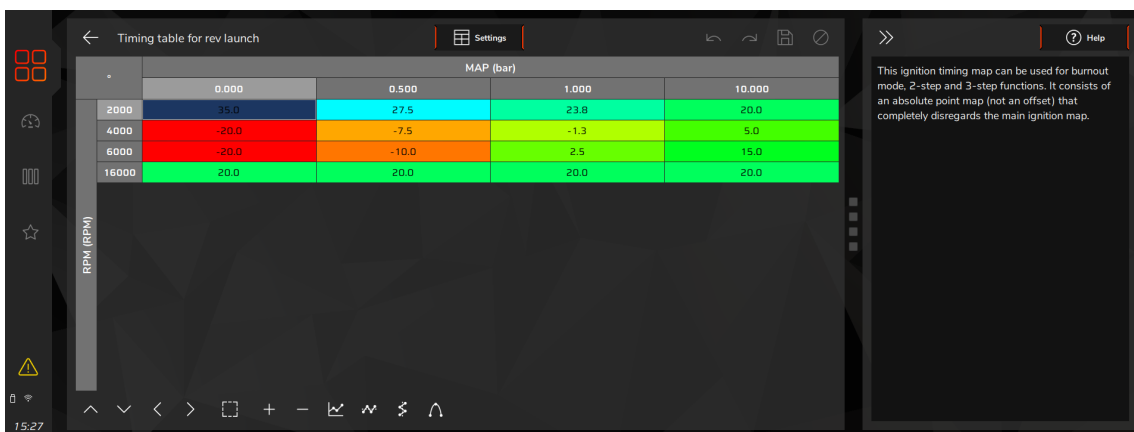

## 21.7 Gear shift output

This feature allows the use of an external solenoid to shift gears, that are three ways to use it: Automatic shift when an RPM is reached, shifting using an input button, and automatic shift by RPM with manual shift by button also allowed.

**Gear shifting mode:** There are three function control modes.

- **Automatic shift by RPM:** Activates the output automatically according to the configured RPM.
- **Manual upshift input button:** Configures a button to activate the output.
- **Automatic shift by RPM & manual upshift allowed:** Both options together.

**Lock time between gear shift:** Sets a time in which the function will be blocked from being activated after a gear change. This prevents the output from being accidentally engaged when shifting more than one gear at a time.

**Output mode:** There are three configuration options. "Single output", "One output Per Gear" or "Automatic transmission control". This setting defines which transmission will be used on the vehicle. Single output only allows you to configure an Air Shift type gearbox. For Lenco and Liberty transmissions, it is necessary to select one output per gear.

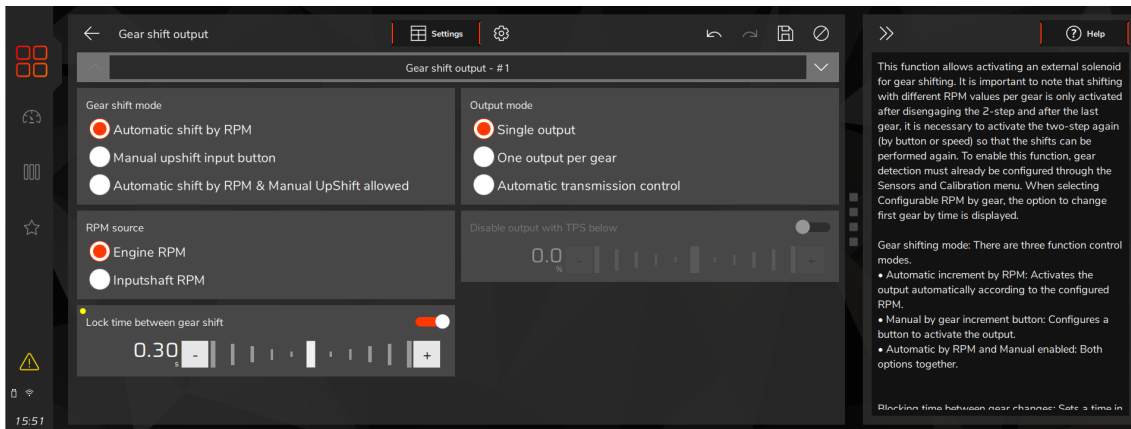

**Gear shift output duration:** Configures how the outputs will be activated according to the configured exchange rate.

- **Single pulse (Air Shift):** It is necessary to set a time to activate the gear shift solenoid. Automatic automatic transmissions / "Clutchless" with pneumatic actuation / Sequential transmission with pneumatic or electric actuation that requires reduction of power type "power shift" (example Suzuki Hayabusa and similar)
- **Remain active (Lenco transmission):** Activates the outputs for each gear that will remain activated until the transmission is disengaged. Lenco drag shift up to 6 gears
- **One output at the time (Libert gearbox):** Activates one output for each gear, which is turned off after changing gear.

**Output pulse duration:** This option will only be available when a Liberty gearbox is used, this configured time is the maximum that the last gear output will be activated.

**RPM Settings:** There are two setting options, by "Single Value" or "Each Gear". This setting is not available if the "Manual by upshift button" mode is selected.

- **Single Value:** Sets an RPM for output triggering.
- **Each gear:** Sets an RPM for each gear shift and also adjusts the minimum time for gear shifting from 1 to 2.

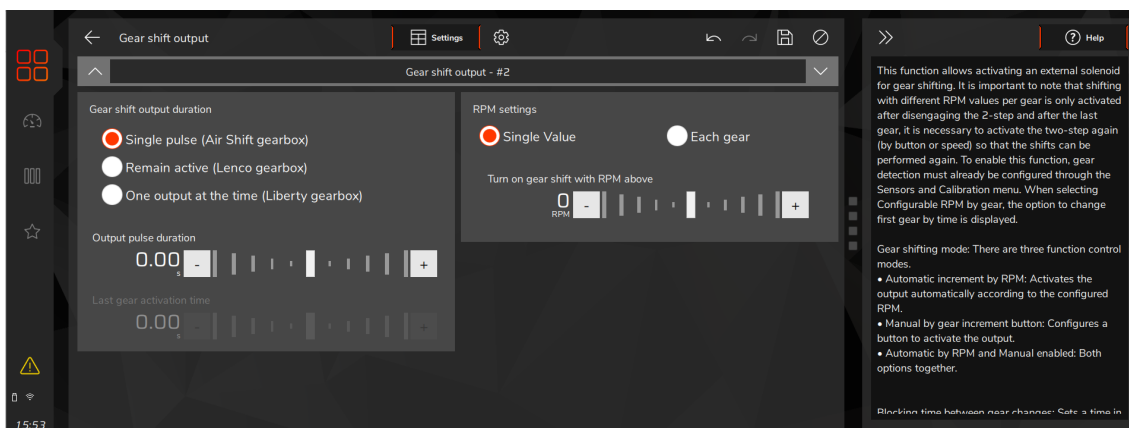

**Power reduction during gear shifting:** By enabling this option, it is possible to configure power reduction by time, reduction and ignition cut. This reduction helps disengage the current gear and engage the next gear.

- **Power reduction delay after output activation:** Configures a delay to start the power reduction after activating the output.

**Power reduction duration:** Sets a time in milliseconds for the duration of the power reduction.

**Ignition timing during power reduction:** Configures an ignition timing reduction for gear shifting.

**Ignition cut on power reduction:** Sets a reduction through an ignition cut for each gear change.

**Cut mode:** Select type of cut will be for power reduction, ignition only or ignition and injection.

**Activate closed loop power reduction duration according to next gear detected:** When this option is checked, the VCU will monitor the gear change, as soon as the gear is engaged, the cut or reduction will be interrupted, even if the configured times are still active.



## WARNING

*When the VCU is requested to apply more than one type of ignition cut from different functions simultaneously, the cut with the highest % configured will have priority, so the function with the lowest % of cut might not operate as expected.*

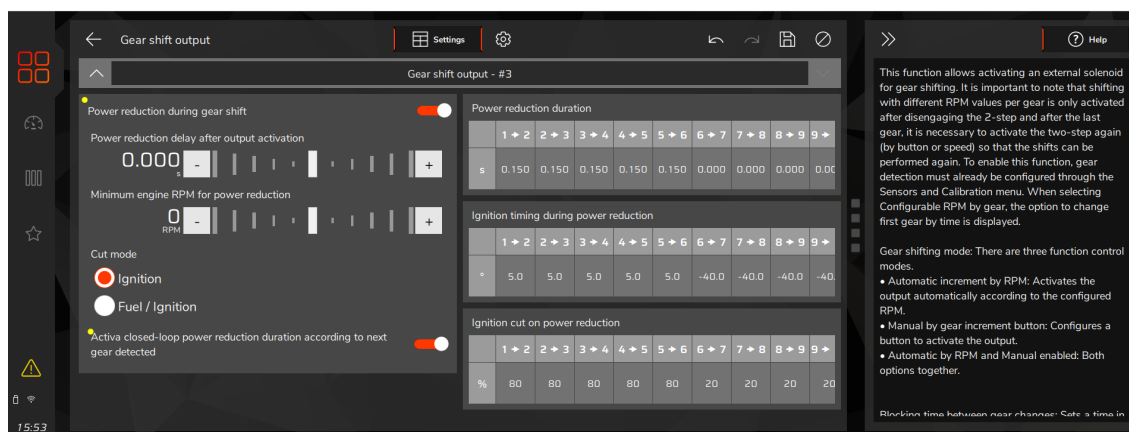

## 21.8 Time based compensations

Series of maps and compensations based on engine speed and RPM. They are used to control the vehicle's traction, especially in the first moments after launch.

As all these compensations depend on the time after launch, the starting point considered is the deactivation of the 2-step.

In order to activate the functions by time, the 2-step must be validated and, for that, you must press the button and release it with the TPS above 50%, or reach the determined rotation cutoff, either from the 2- step, like 3-step.

**Time based engine RPM (cut):** This control creates a “temporary” RPM limiter based on rotation points and time. The time count starts after the deactivation of the 2-step (which marks the start of the start). The configuration table allows the programming of the desired time and RPM. If the engine RPM shoots after the start and reaches the programmed rotations in the table, the VCU sends ignition cuts in order to recover the traction of the tires.

**Time based driveshaft RPM (cut) - Limit:** This curve changes the maximum level of ignition cut during the rotation control by time, it determines the maximum level of cut by time. In some cases, 90% threshold (default value) can be too aggressive, causing more than desired de-power and increasing track time. By changing the clipping limit it is possible to modulate the engine power more precisely.

**Time based engine RPM (advance/retard):** This control is very similar to the Rotation Control by Time, however, instead of sending ignition cuts to the coils, this function delays or advances the ignition timing in order to reduce engine power and control traction losses.

This function starts after deactivating the 2-step button, which marks the start of the start. It must work together with the cut control and be programmed always keeping in mind that the delay control must be reached before the cut control, in order to smooth even more the launch of the vehicle.

**Time based driveshaft engine RPM (advance/retard) - timing:** This curve changes the ignition timing applied to the engine RPM, it determines the ignition based on time.

The initial parameter to be configured is the RPM progression range, which basically serves to smooth the cut applied to the engine.

Using a progression range of 200RPM means that, to apply a cutoff at 8000RPM, the VCU will start with a low cutoff level, and will progressively increase it until reaching the value configured in the "Ignition Cutoff Curve".

In this case, the RPM can go up to 200RPM from the desired cut, allowing the motor to rotate up to 8200RPM (8000 + 200RPM of the progression range) in extreme situations where the maximum configured cut percentage is required.

Then configure the cut RPM as a function of time after the start to apply the cuts. If the engine RPM shoots after the start and reaches the programmed rotations in the table, the VCU sends ignition cuts in order to recover the traction of the tires.

It is possible to configure the percentage of ignition pulses that will be clipped to hold the engine RPM with this control. For SparkPRO type inductive ignitions and coils with integrated module use 90% maximum cutoff level and 200RPM progression range. For MSD type capacitive ignitions, 100% maximum cutoff level and 10RPM of progression range is recommended.

Values lower than 90% may not "hold" the motor. Larger values of the progression range tend to stabilize the cut more smoothly, but exceed the established value of the cut.

After programming the table, a graph of the ignition cut-off ramp created by the function is displayed.

### Graph identification

- 1 - Active functions
- 2 - Enables the display of the graph of the function
- 3 - Table editing bar: it is possible to add, remove and edit the table as needed
- 4 - Graphs of the functions: they are fully editable and it is possible to make all the adjustments with a simple touch on the highlighted line.
- 5 - Editing table: it is possible to edit the graphics through the table, just pressing on the cell that you want to change.

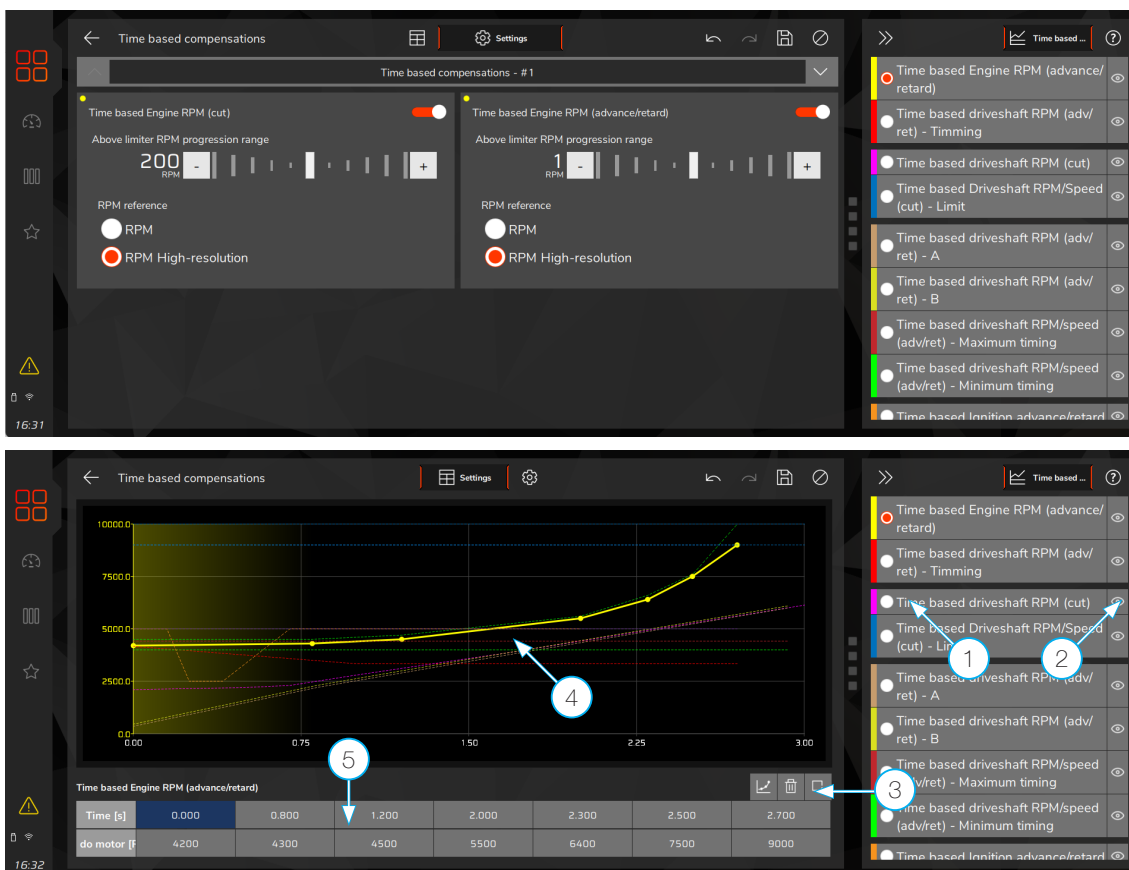

**Time based Driveshaft RPM/Speed (cut):** The Drive shaft speed/RPM control by time (cut) performs ignition cuts whenever the traction wheel speed (or Drive shaft RPM) exceeds the programmed curve. In more general terms, this control limits the maximum speed that the vehicle's drive wheel can reach within seconds of starting. It is mandatory that a wheel speed sensor is already configured and working correctly to use this control.

The initial parameter to be configured is the RPM progression range, which basically serves to smooth the cut applied to the engine.

Using a progression range of 20 km/h means that, to apply a cutoff at 80 km/h, the VCU will start with a low cutoff level, and will progressively increase it until reaching the value set in the "Ignition cutoff curve".

In this case, the speed can go up to 20 km/h from the desired value, allowing the drive wheel (or Drive shaft) to reach up to 100 km/h (80 km/h + 20 km/h of the progression range) in extreme situations where the maximum configured cut percentage is required.

**Time based driveshaft RPM/Speed (cut) - Limit:** This curve changes the maximum level of ignition cut during speed control by time, it determines the maximum level of cut by time. In some cases, 90% threshold (default value) can be too aggressive, causing more than desired de-power and increasing track time. By changing the clipping threshold it is possible to modulate the engine power more precisely.

**Time based driveshaft RPM/Speed (advance/retard) - A and B:** This control reads the speed of the traction wheel (or the RPM of the Drive shaft) and applies two levels of point delay, according to two RPM curves (upper and lower). bottom) to control the speed. The basic idea is to delay the ignition timing, reducing power to the wheels. If the speed exceeds the programmed value in the lower curve, the second point delay curve comes into play, with even more aggressive ignition delay values.

As the speed increases and goes towards the "velocity curve B", the point delay applied to the motor (which is interpolated between the two delay curves) is incremented. In this way, if the initial delay caused by curve A is not enough to control the vehicle speed, as it rises, the point delay applied to the engine increases.

In cases where the speed exceeds the limits of the "speed curve B" the maximum delay programmed by time in the "point delay curve B" will be applied.

It is mandatory that a wheel speed sensor is already configured and working correctly to use this control.

**Configuration tables and curves:** The speed by time (advance/delay) RPM A and RPM B, correspond to the upper and lower levels of Speed/Rotation that will be reached first if the vehicle loses traction:

- Speed (advance/retard) - A: Upper curve of Speed/maximum rotation by time.
- Speed (advance/retard) - B: Lower speed/minimum speed curve by time.
- Speed curves by time (retard) - Point A and Point B, correspond to the lower and upper levels for the timing delay.
- Speed (retard) - maximum timing: Upper speed curve by ignition timing delay
- Speed (retard) - minimum timing: Lower speed curve by timing delay

When the car pulls out of park and approaches the minimum or maximum speed/rev curve (RPM A and RPM B), the ignition timing will be delayed according to the Speed curves (Point A and Point B).

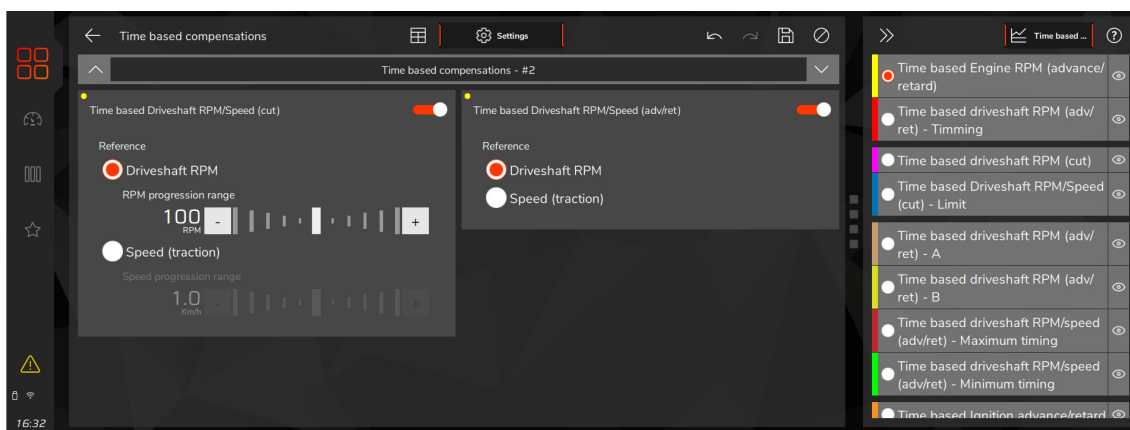

**Time based ignition advance/delay:** Activates an ignition timing compensation map as a function of time after the start, initiated after the 2-step deactivation (drag cut). It is a very simple compensation that relates the time after the start with the desired ignition timing compensation. At the end of the configuration, a point compensation graph is displayed as a function of time after the start.

**Time based enrichment:** Activates a fuel compensation map as a function of time after the start, started after deactivating the 2-step (drag cut). This offset relates the time (in seconds) after launch to the desired fuel offset. At the end of the configuration, a fuel enrichment graph is displayed as a function of time after the start.

If the dot delay applied by the lower velocity curve isn't enough to return traction, the upper velocity curve kicks in, which applies more aggressive dot delays.

**Time based max electronic throttle opening:** configures a ramp for opening the throttle. To configure this curve, it is necessary to be in the "custom" mode configured ETC in "engine settings / Pedal/throttle".

**Watergate Pressure:** Adjusts the boost pressure ramp. It is necessary to have the BoostController function configured.

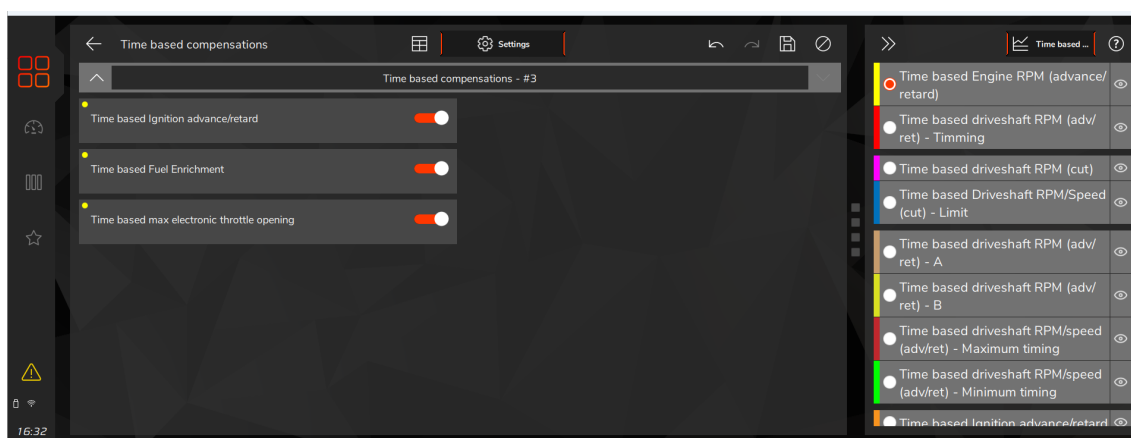

## 21.9 Pro-Nitrous

This feature is designed to allow the use of up to 6 time based stages of nitrous with individual settings for each stage. The activation of the Pro-Nitrous feature must fill the 3 requirements:

- 1 - Enable a button on the dashboard of the VCU or an external switch (configured in one of the white inputs).
- 2 - The time after releasing two-step switch cannot be higher than 15 seconds, otherwise the Pro-Nitrous will not activate. In other words, the vehicle must launch within 15 seconds after releasing the two-step button.
- 3 - The TPS must be set above the minimum.

With these three requirements, Pro-Nitrous tables will start and follow the setup time. The fuel and timing compensations will also begin at this point. If a condition is not met, Pro-Nitrous is deactivated and the control follows standard ignition, fuel and closed loop tables.

**Enable function by:** There are two ways to enable Pro-Nitrous, by button or Always enable

- **Pro-Nitrous Button:** Configures an on-screen button on the VCU for Pro-Nitrous activation.
- **Always enabled:** This option will leave the function always active while the VCU is on.

**Input activation mode:** Select whether the external switch will be triggered by 0V (ground) or 12V (positive).

**TPS to Pro-Nitrous activation:** Configures a minimum and maximum percentage of TPS for activating the Pro-Nitrous function.

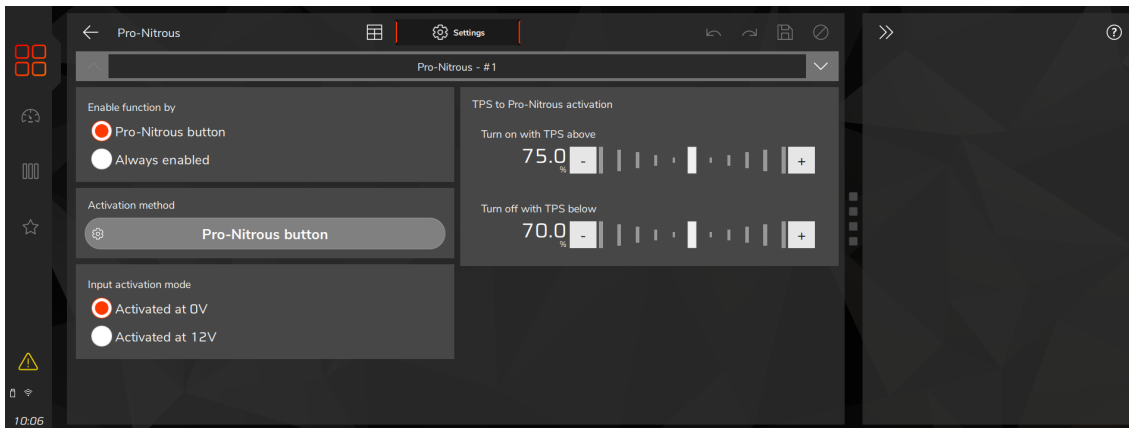

**Stage activation output:** Select whether the outputs will be activated by 0V (blue or gray wires) or 12V (yellow wires).

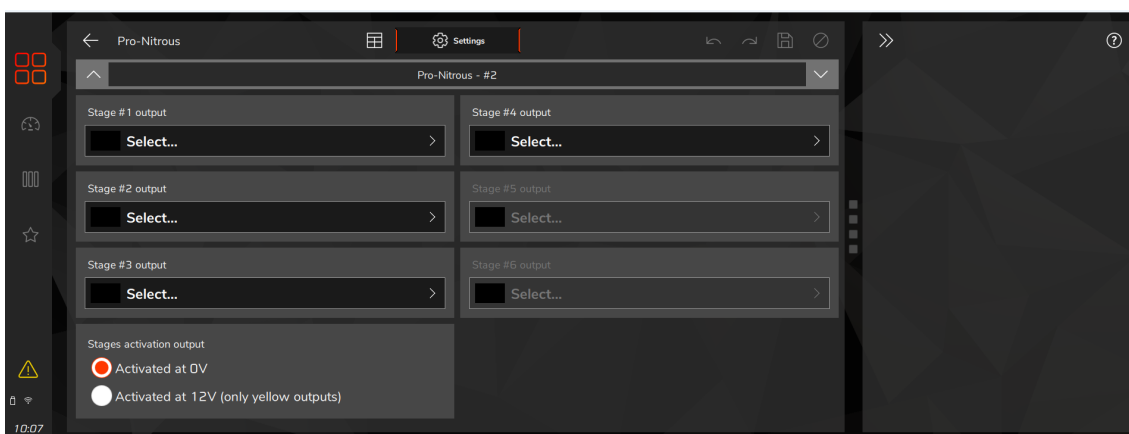

**Pro-Nitrous activation window:** Pro-Nitrous has two TPS thresholds that allow it to trigger only when the TPS is within the configured window. Thus, the pilot is free to relieve the TPS and recover from a loss of traction without turning off the nitrous injection.

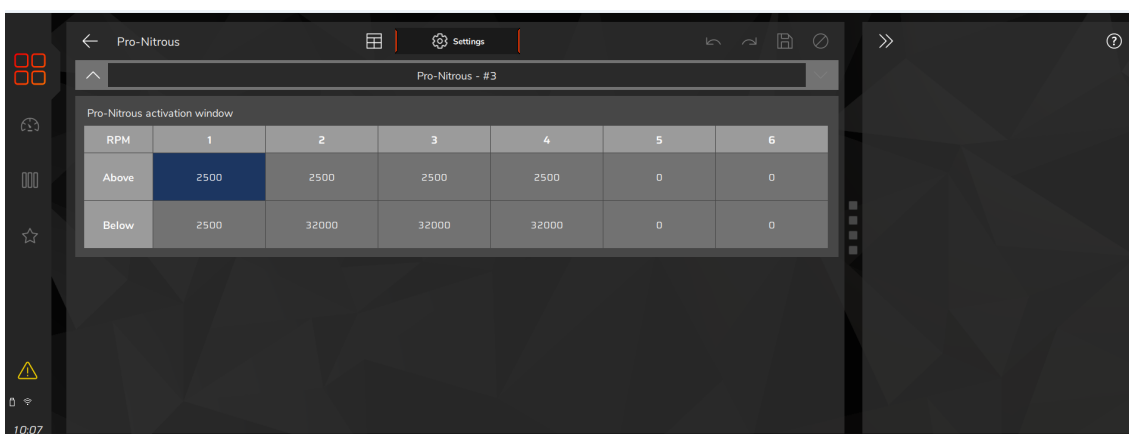

**Pro-Nitrous timers and delays:** These are settings for timings to start the nitrous stages and the ignition and fuel offsets.

- **ON after launch:** time for nitrous stage activation after 2-step release.
- **OFF after launch:** time to deactivate the nitrous stage after releasing the 2-step.
- **ON after pedaling:** time to reactivate the nitrous stage after the racing driver pedals the accelerator (he took his foot off for a trajectory correction and accelerated again).

**Fuel compensation:** Three options

- **ON delay:** Time after the start of the nitrous stage that fuel or ignition trim will be applied.
- **OFF delay:** Time during which fuel or ignition trims will be maintained after the end of the nitrous stage.
- **OFF ramp:** duration time of the smoothing ramp for fuel trim shutdown or ignition after the end of the nitrous stage. Fuel or ignition trim is gradually removed during this time.

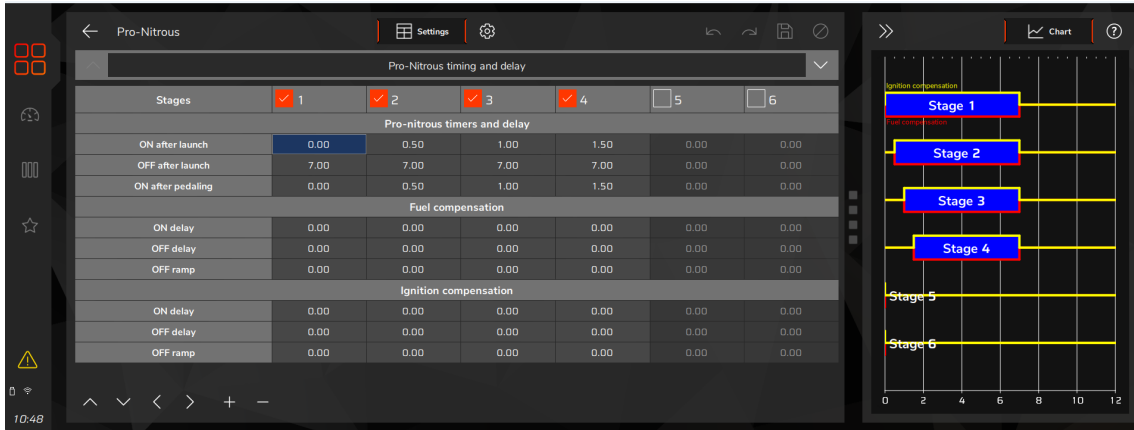

**Nitrous stages fuel table:** Fuel compensation based on the main fuel table, which will have their values increased or reduced.

If a delay to start the compensation was previously setup, while this time has not elapsed, will remain valid only previous stages compensations. For the first stage, only the main fuel table and its compensations will be applied.

The screenshot displays the 'Nitrous stages fuel table' settings. It shows a table with columns for RPM (2000, 4000, 5500, 6000, 6500, 7000, 7500, 8000, 8500, 9000, 9500, 10000, 10500, 11000, 12000, 12000) and rows for stages (1-6). The values are currently all 0.000.

ms	RPM (RPM)															
	2000	4000	5500	6000	6500	7000	7500	8000	8500	9000	9500	10000	10500	11000	12000	12000
1	0.000	0.000	0.000	0.000	0.000	0.000	0.000	0.000	0.000	0.000	0.000	0.000	0.000	0.000	0.000	0.000
2	0.000	0.000	0.000	0.000	0.000	0.000	0.000	0.000	0.000	0.000	0.000	0.000	0.000	0.000	0.000	0.000
3	0.000	0.000	0.000	0.000	0.000	0.000	0.000	0.000	0.000	0.000	0.000	0.000	0.000	0.000	0.000	0.000
4	0.000	0.000	0.000	0.000	0.000	0.000	0.000	0.000	0.000	0.000	0.000	0.000	0.000	0.000	0.000	0.000
5	0.000	0.000	0.000	0.000	0.000	0.000	0.000	0.000	0.000	0.000	0.000	0.000	0.000	0.000	0.000	0.000
6	0.000	0.000	0.000	0.000	0.000	0.000	0.000	0.000	0.000	0.000	0.000	0.000	0.000	0.000	0.000	0.000

The screenshot displays the 'Nitrous total calculated fuel table' settings. It shows a table with columns for RPM (2000, 4000, 5500, 6000, 6500, 7000, 7500, 8000, 8500, 9000, 9500, 10000, 10500, 11000, 12000, 12000) and rows for stages (1-6). The values are calculated based on the main fuel table and compensation.

ms	RPM (RPM)															
	2000	4000	5500	6000	6500	7000	7500	8000	8500	9000	9500	10000	10500	11000	12000	12000
1	2.906	3.995	4.634	4.721	4.809	4.896	4.905	4.911	4.916	4.868	4.765	4.664	4.562	4.460	4.256	0.176
2	2.906	3.995	4.634	4.721	4.809	4.896	4.905	4.911	4.916	4.868	4.765	4.664	4.562	4.460	4.256	0.176
3	2.906	3.995	4.634	4.721	4.809	4.896	4.905	4.911	4.916	4.868	4.765	4.664	4.562	4.460	4.256	0.176
4	2.906	3.995	4.634	4.721	4.809	4.896	4.905	4.911	4.916	4.868	4.765	4.664	4.562	4.460	4.256	0.176
5	2.906	3.995	4.634	4.721	4.809	4.896	4.905	4.911	4.916	4.868	4.765	4.664	4.562	4.460	4.256	0.176
6	2.906	3.995	4.634	4.721	4.809	4.896	4.905	4.911	4.916	4.868	4.765	4.664	4.562	4.460	4.256	0.176

**Nitrous bottle pressure compensation:** Fuel compensation table based on nitrous bottle pressure. The lower is the pressure, less nitrous is injected and therefore less fuel is needed. Required to have an input configured as Nitrous pressure.

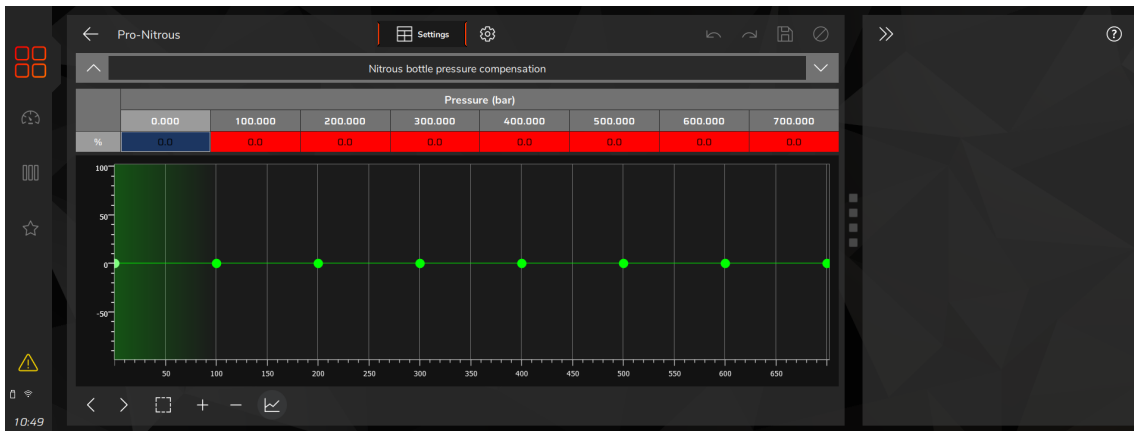

**Nitrous stages cylinder trim:** Individual cylinder fuel trim based on Pro-Nitrous stages. Allows the equalization of the air-fuel mixture on all cylinders according to each Pro-Nitrous stage.

%	Stage (stg)					
	1	2	3	4	5	6
1	0.0	0.0	0.0	0.0	0.0	0.0
2	0.0	0.0	0.0	0.0	0.0	0.0
3	0.0	0.0	0.0	0.0	0.0	0.0
4	0.0	0.0	0.0	0.0	0.0	0.0
5	0.0	0.0	0.0	0.0	0.0	0.0
6	0.0	0.0	0.0	0.0	0.0	0.0
7	0.0	0.0	0.0	0.0	0.0	0.0
8	0.0	0.0	0.0	0.0	0.0	0.0

**Nitrous stages timing table:** Timing compensation applied based on the main timing table, which will have their values increased or decreased.

°	RPM (RPM)															
	2000	4000	5500	6000	6500	7000	7500	8000	8500	9000	9500	10000	10500	11000	12000	32000
1	-10.0	-10.0	-10.0	-10.0	-10.0	-10.0	-10.0	-10.0	-10.0	-10.0	-10.0	-10.0	-10.0	-10.0	-10.0	-10.0
2	-6.0	-6.0	-6.0	-6.0	-6.0	-6.0	-6.0	-6.0	-6.0	-6.0	-6.0	-6.0	-6.0	-6.0	-6.0	-6.0
3	-2.0	-2.0	-2.0	-2.0	-2.0	-2.0	-2.0	-2.0	-2.0	-2.0	-2.0	-2.0	-2.0	-2.0	-2.0	-2.0
4	-2.0	-2.0	-2.0	-2.0	-2.0	-2.0	-2.0	-2.0	-2.0	-2.0	-2.0	-2.0	-2.0	-2.0	-2.0	-2.0
5	0.0	0.0	0.0	0.0	0.0	0.0	0.0	0.0	0.0	0.0	0.0	0.0	0.0	0.0	0.0	0.0
6	0.0	0.0	0.0	0.0	0.0	0.0	0.0	0.0	0.0	0.0	0.0	0.0	0.0	0.0	0.0	0.0

## 21.10 Time based output

This feature allows activating an auxiliary output by time, which can be used to release the parachute, turn on the nitrous or even switch on the torque converter lockup solenoid.

There are some conditions that can be programmed to activate this output, such as the time for it to be activated after the 2-step.

This output can work on/off (being turned off when one of the conditions is no longer valid) or as a Pulse (for cases such as activating the parachute).

**Time to trigger after 2-step:** Adjusts the time value that the function will be activated after exiting the 2-step condition. There are some conditions that can be configured to trigger the output, such as minimum RPM, TPS and speed.

**Output trigger type:** There are two trigger options, if necessary choose between on and off or a pulse.

- **ON/OFF:** This output can work on/off (being turned off when one of the conditions is no longer valid).
- **Pulse:** Used, for example, for cases such as activating the parachute.

**Minimum RPM to trigger:** Program a minimum RPM to activate the output.

**Minimum TPS for activation:** Configures a percentage of TPS to activate the output.

**Minimum driveshaft RPM to trigger:** Program a minimum driveshaft RPM to activate the output.

**Minimum speed to trigger:** Sets a minimum speed for activating the output.

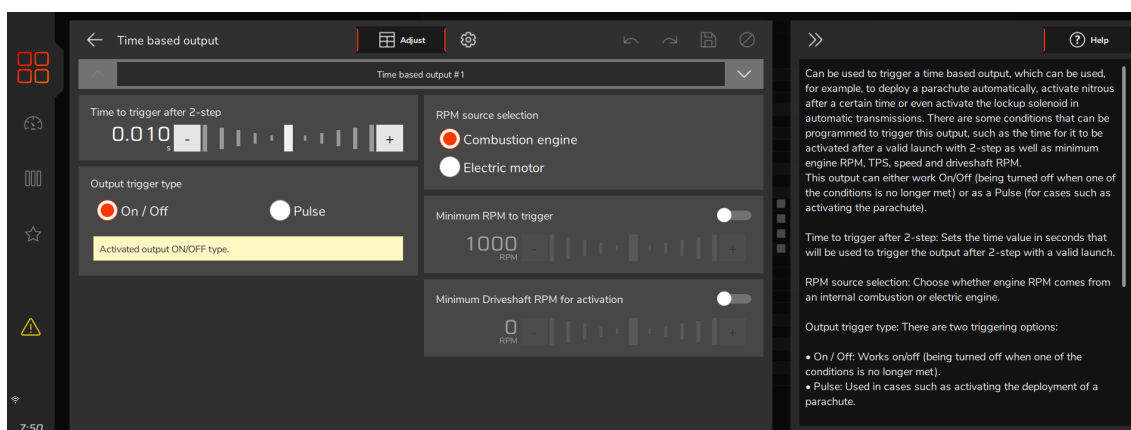

## 21.11 Wheelie control

This feature uses the ride height and tilt sensors readings to prevent the vehicle from lifting the front above a dangerous height. Recommended for rear wheel drive vehicles, including motorcycles.

**Retard and cut stage:** this feature retards the ignition timing whenever the front of the vehicle rises above the configured height limit, and the cut stage sends ignition cuts to control the front height of the vehicle.

The delay stage is a first attempt to control the rising of the front of the vehicle, and the cut stage is the most aggressive way to prevent the front from continuing to lift.

**Retard and cut stage mode:** there are two options

- **Always enabled:** this feature will remain active whenever the engine is running, regardless of any other function, even if the vehicle is suspended in a lift for testing. This mode is recommended for motorcycles.
- **Drag racing only:** this feature will be activated only after the 2-step is released and will last enabled for a period of 15 seconds only.

**Ride height for retard and cut stage:** Set the height to activate each stage. In general the delay stage is activated before the cut stage. A white input must be set as "Ride height" in order to enable this function.

**Pitch angle for retard and cut stage:** Set the pitch rate (in degrees per second) to activate the function. Both sensors (height and pitch) can be used simultaneously.

A white input must be set as "Pitch rate" in order to enable this function.

**Timing retard (retard stage only):** Ignition timing retard that will be applied to the map when the delay stage is activated.

**Timing return ramp (retard stage only):** Time in seconds (s) for the ignition timing to return to the normal timing map after the delay stage has been activated.

**Minimum cut duration (cut stage only):** Ignition cut duration time in seconds (s) when the cut stage is activated.

**Timing retard output activation:** This function allows the VCU to trigger an output when any of the stages is activated. Brake, parachute, gear shift, or other means may be used to prevent the front of the vehicle from continuing to rise. To do this, select whether you want the output to send negative (activated at 0V) or positive (activated at 12V - yellow outputs only) to trigger the relay or actuator.



## WARNING

*When the VCU is requested to apply more than one type of ignition cut from different functions simultaneously, the cut with the highest % configured will have priority, so the function with the lowest % of cut might not operate as expected.*

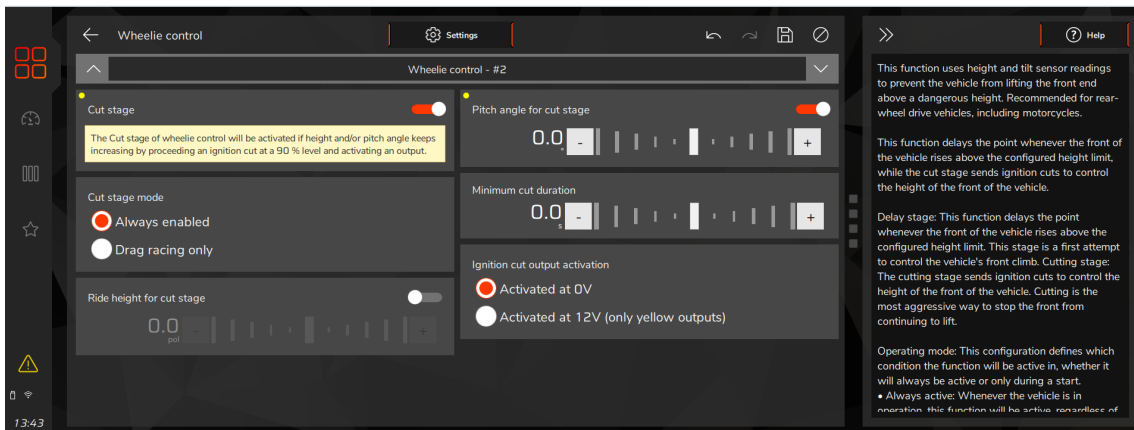
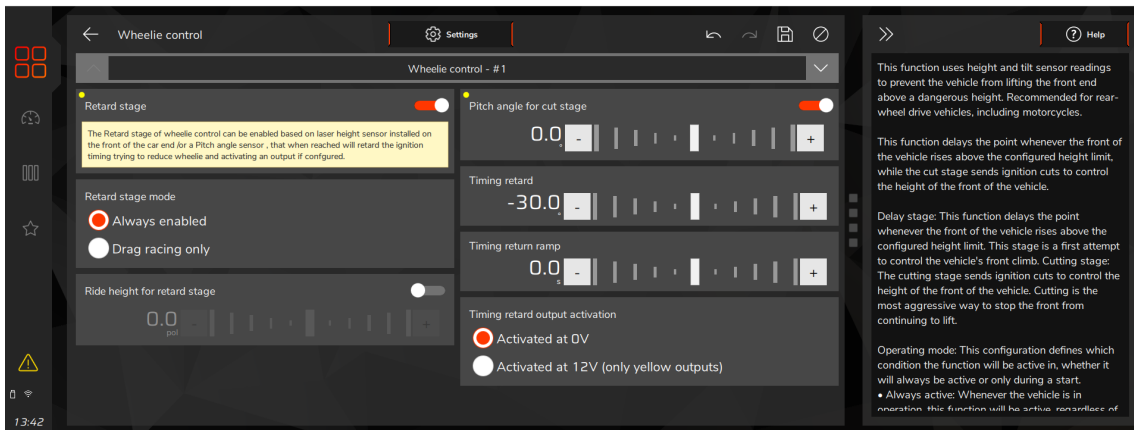

## 21.12 Staging control / Transbrake

This function helps the car alignment when pre-staging after the burnout. When activated, it's possible to control the transbrake solenoid frequency to hold the car properly.

**Transmission staging intensity:** When activated, the VCU will reduce the transbrake pulse percentage, causing the car to move slightly.

**PWM Frequency:** It is possible to configure the frequency at which the pulses will occur.

**Transbrake activated during:** It can be configured for activation during 2-step and/or 3-step.

**Activate staging control:** It can be configured for activation during 2-step and/or 3-step.

**Maximum time for output duration (solenoid protection):** To avoid problems with the transbrake solenoid, there is an option for the maximum activation time of the function.

**Button presses to apply the additional intensity:** In some situations, the driver may need to press the button many times for the car to reach the starting position. To avoid this, there is an option to increase the alignment control pulse after a defined number of function activations.

**Additional intensity:** sets a percentage increase in the solenoid actuation.

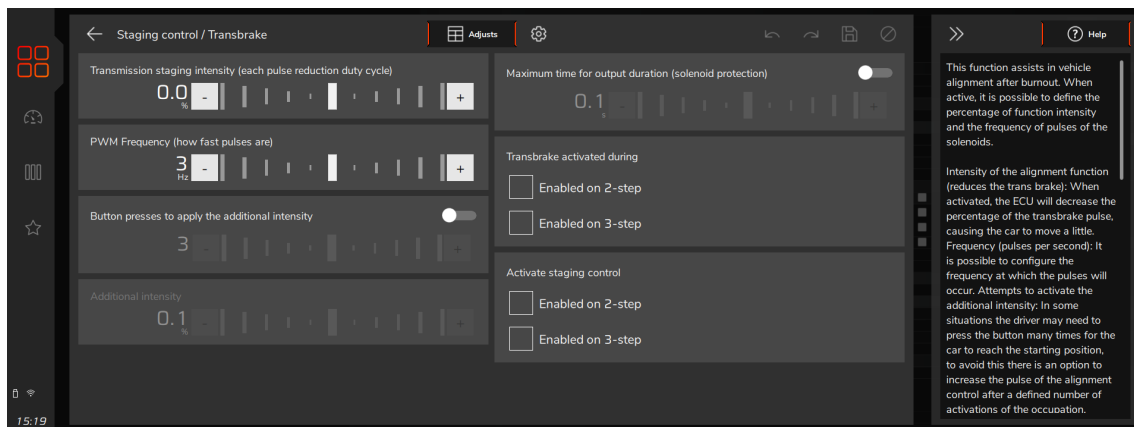

**Button activation mode:** It is possible to configure the polarity of the button and output activation, whether 0V or 12V.

**Output activation signal:** Configures the output signal as 0V (ground) or 12V (positive)

**Secondary output activation signal:** Sets a second solenoid to control the transbrake, very useful in turbo cars where more than one solenoid is needed to hold the car braked.

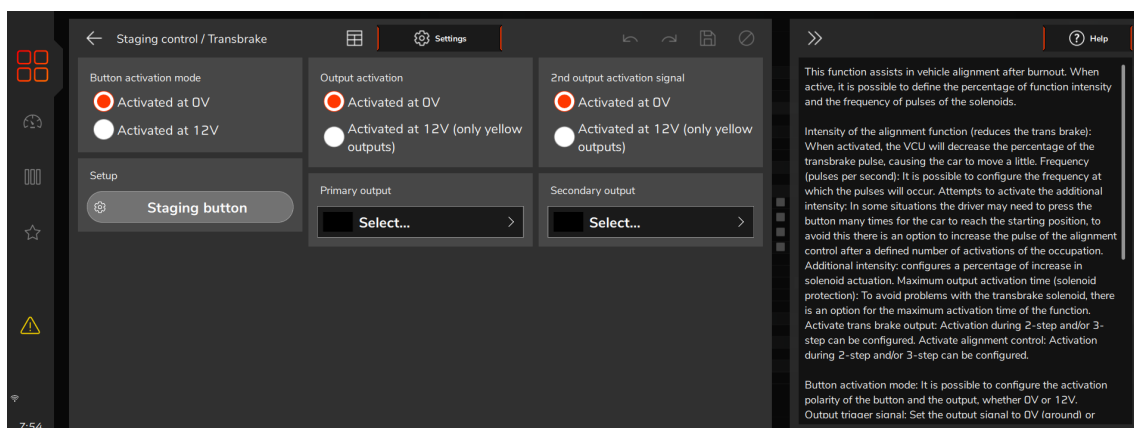

### 21.13 Mechanical fuel injection controller (MFI)

The Mechanical Injection Fuel Controller is used to activate or deactivate solenoids that decrease the amount of fuel that goes to the engine (Lean out solenoids) in cars that use mechanical fuel injection (without fuel injectors).

The function can be enabled by a button on the ECU dashboard, by an external switch (requires an appropriately configured analog input) or always active when the ECU is switched on.

When the external key is selected, it is necessary to configure how the input activation mode will be, whether by 0V or 12V.

There are up to 8 stages that can be triggered after the launch with a configurable RPM window, 2-step or 3-step trigger selection, and make the desired ignition compensations during staging.

The stages channels triggered during a start can be visualized in the log, as well as the ignition compensation of each stage.

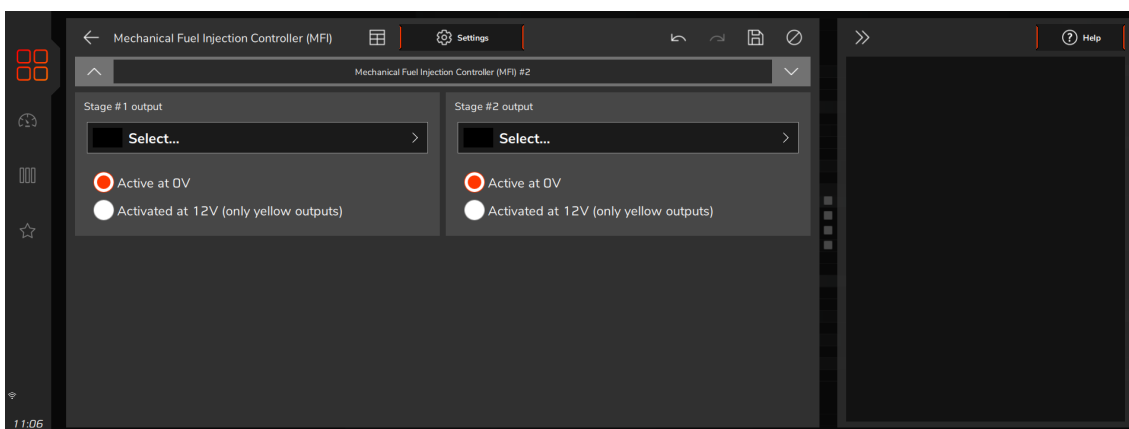
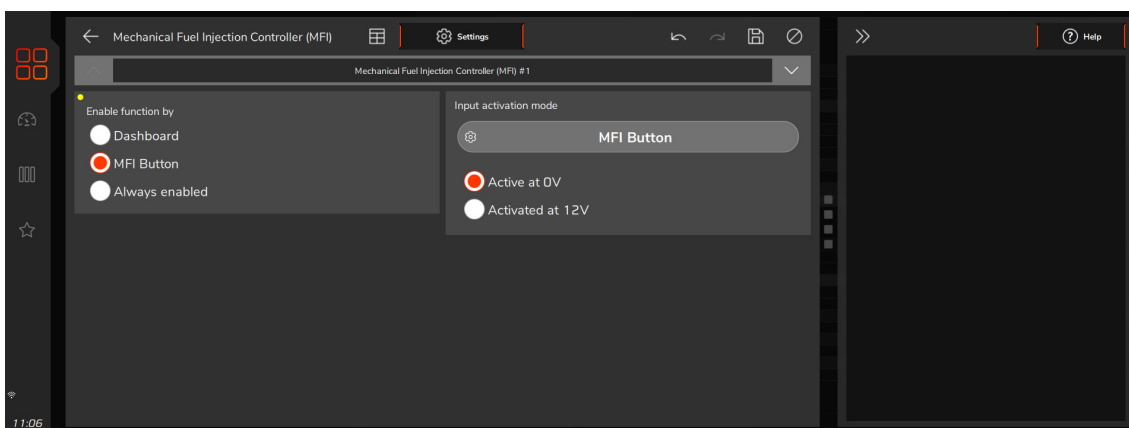

### Timers and Delays

Stages can be triggered within a RPM window and/or maintain the desired stages during the 2-step and 3-step by enabling them in the check boxes.

Stages control is done by time after the 2-step with a validated launch, being configurable an activation and deactivation time for that stage output, and there is still the possibility to activate and deactivate the same stage up to three times during the same launch.

The ignition compensations for each stage can be activated or deactivated with a delay time in relation to the fuel solenoid activation time, thus seeking to get the exact time that ignition timing needs to be changed to equal the fuel difference that is going to the engine.

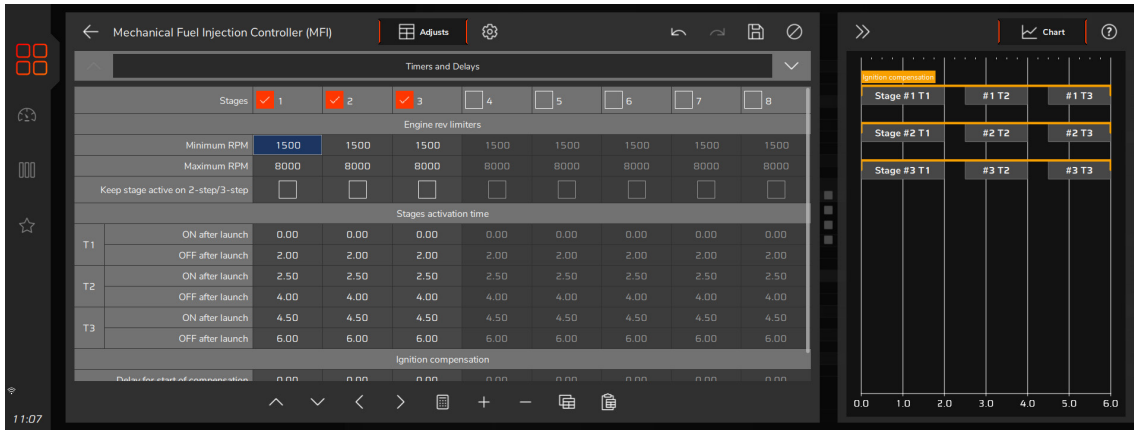

### MFI stages ignition

Ignition stages compensations are set Stage x RPM table in °BTDC. The value set in the first table will advance or retard ignition timing on the main ignition table.

The second table will shown main ignition timing table with MFI compensations of the selected stages, however all other ignition compensations configured in the Ignition Tables section will still be applied.

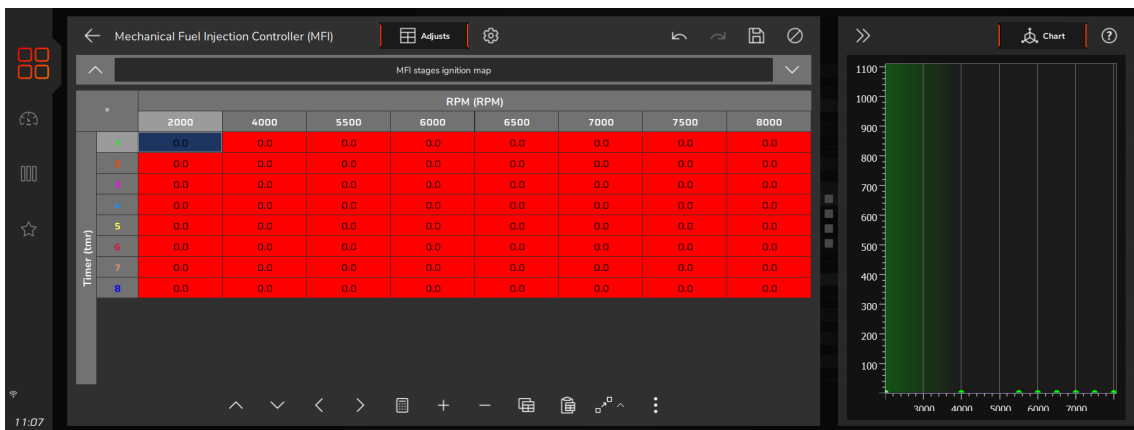

### 21.14 Time based individual fuel trim

This function allows you to set an individual fuel injection percentage per cylinder and time. This setting can be performed on banks A, B and C independently.

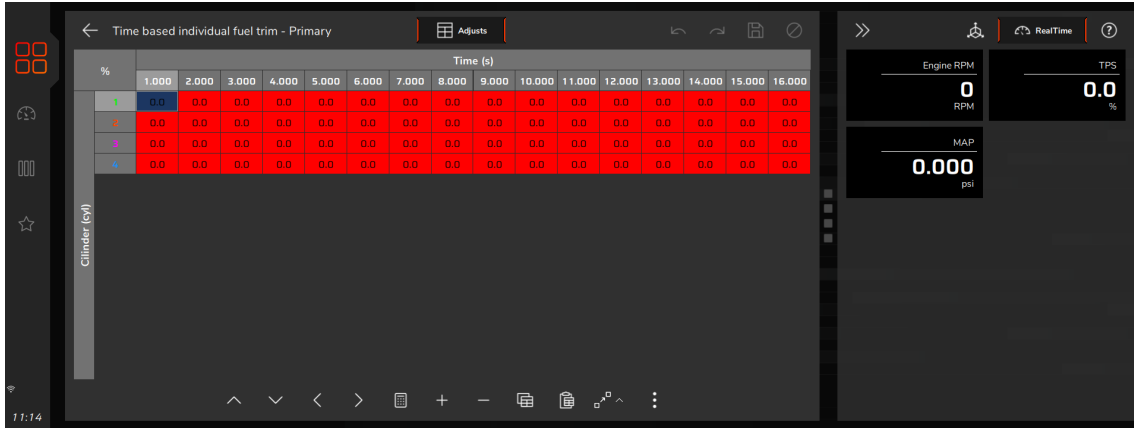

### 21.15 Time based individual ignition trim

This function allows you to set an individual ignition point per cylinder and per timing.

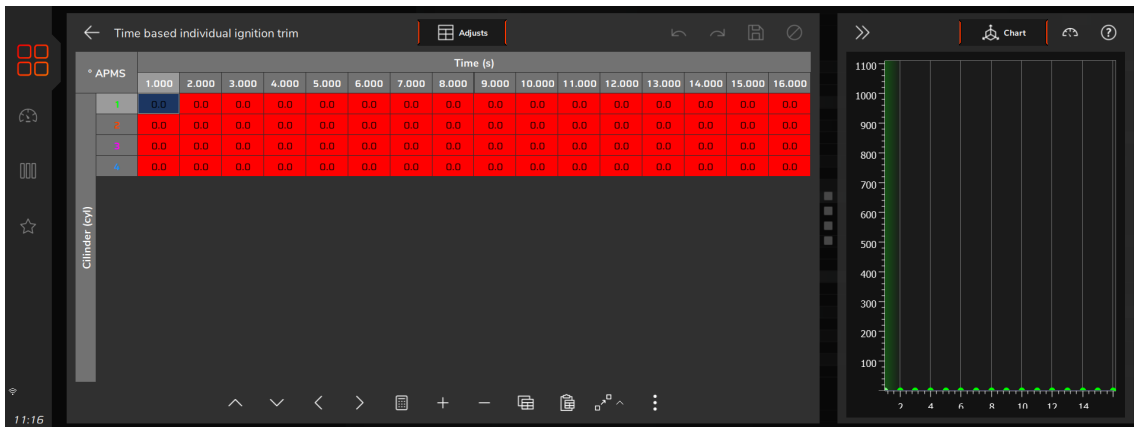



# ***ALERTS***

Settings

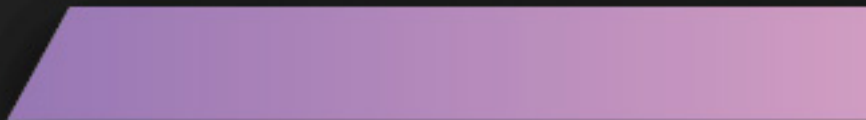

## 22. Alerts Settings

Alert settings allows the programming of sound and visual alerts whenever a dangerous situation to the engine is detected. It is possible to setup up to three different actions when any alert is displayed on the screen.

### IMPORTANT

*This Feature will only work when the ECU is on the Dashboard Screen*

The configuration of alerts allows the programming of sound and visual alerts whenever a dangerous situation to the engine is detected. It is possible to setup up to three different actions when any alert is displayed on the screen:

**Alert only:** alert is displayed on the screen, but the engine continues to work normally.

**Safe mode:** besides the alert displaying on the screen, engine has its max RPM limited to what was set up on the “Safe mode rev limiter” parameter

**Engine shut off:** besides the alert displayed on the screen, engine is immediately shut off by fuel and ignition cut.

### 22.1 General configuration of alerts (Safe mode)

Safety mode allows you to protect the engine whenever an alert is activated, limiting the maximum engine speed that the engine can reach while the alert condition exists.

It is also possible to configure an alert output so that when an alert condition is reached, the output is automatically activated.

By checking “Keep output activated until engine restarts”, the ECU will remain in safety mode until the engine is restarted.

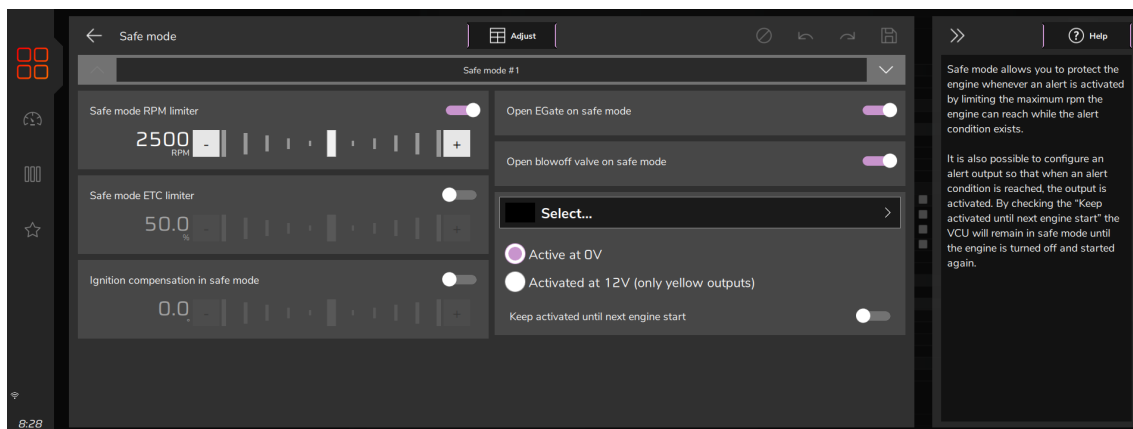

### NOTES

*Keep in mind that the alerts programmed here can happen at any time, including during overtakes, turns, passes at the track and on the dynamometer. Be careful when selecting the “turn engine off” option and use it only for vital engine alerts.*

**Over rev:** Setup the RPM for alert and the action the ECU must perform.

**Overboost:** Setup an overboost value to activate the alert and the action the ECU must perform.

**Injector duty cycle:** Setup a percentage value that indicates injectors saturation.

**High EGT:** Setup what is considered a high exhaust temperature to alert.

**Oil pressure:** Setup a value that's considered as oil pressure excess and one that's considered for low oil pressure.

Also, select what the ECU must perform when this alert is activated. It is possible to configure a RPM table alert for low oil pressure and different activation time. When selecting option by RPM table, a new tab will be available just below the Alert Settings menu.

**Minimum oil pressure @RPM:** Setup a minimum oil pressure value above X RPM and the action the ECU must perform.

**Low EGT:** Setup what is considered a low exhaust temperature to alert.

**EGT increase rate:** alert that identifies when an EGT sensor raises temperature quickly, possibly identifying a problem in one or more cylinders. This alert monitors EGT temperatures only during a validated launch.

**Pan vacuum rate:** alert that monitors pan vacuum rate during a validated launch.

**Engine temperature:** Setup an engine temperature to activate the alert and the action the ECU must perform.

**Low fuel pressure:** Setup a value to activate the alert and the action the ECU must perform.

**Base fuel pressure:** Setup here a tolerance for the base fuel pressure.

The base fuel pressure is what the pressure regulator should keep with MAP = 0 psi, that, in most of cases is 45psi with the engine turned off and the fuel pump turned on. When engine is turned on, the vacuum/boost makes the fuel pressure regulator to manage the fuel pressure in a 1:1 ratio.

**Turbo overspeed:** alert that indicates high speed in one or both turbocharger, protecting it against possible damage.

**O2 closed loop:** Correction limits exceeded: An alert will show when the O2 correction reaches upper or lower limits configured in the map.

**Flex fuel sensor error:** In cases where the sensor has read problems or is disconnected, alert will be displayed, the engine will enter safe mode or switch off.

**Overboost by % ethanol:** It is possible to enable overboost alert according to the amount of ethanol used. When you select this alert, a table is available in the Alerts Settings menu.



**FILE**

Manager



## 23. File Manager

With the settings manager, it is possible to switch between the injection maps saved in the memory; each position has different settings and adjustments. This allows, for example, different adjustments for different types of fuel.

Another option is to use the same module for different engines that can share the injection, but with their settings saved. For this, one or more extra wiring harnesses can be purchased.

Through the VisionFT software, the File Manager functions are available from the button (1) on the toolbar:

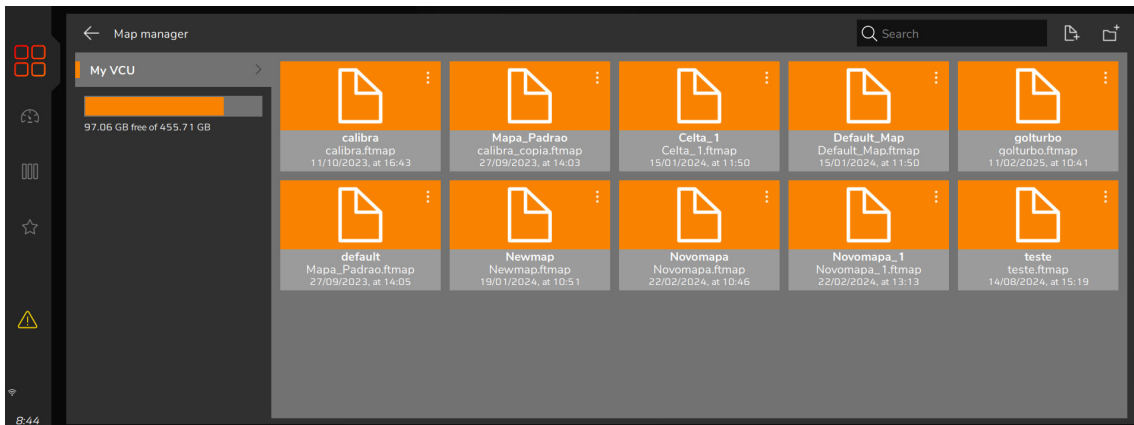
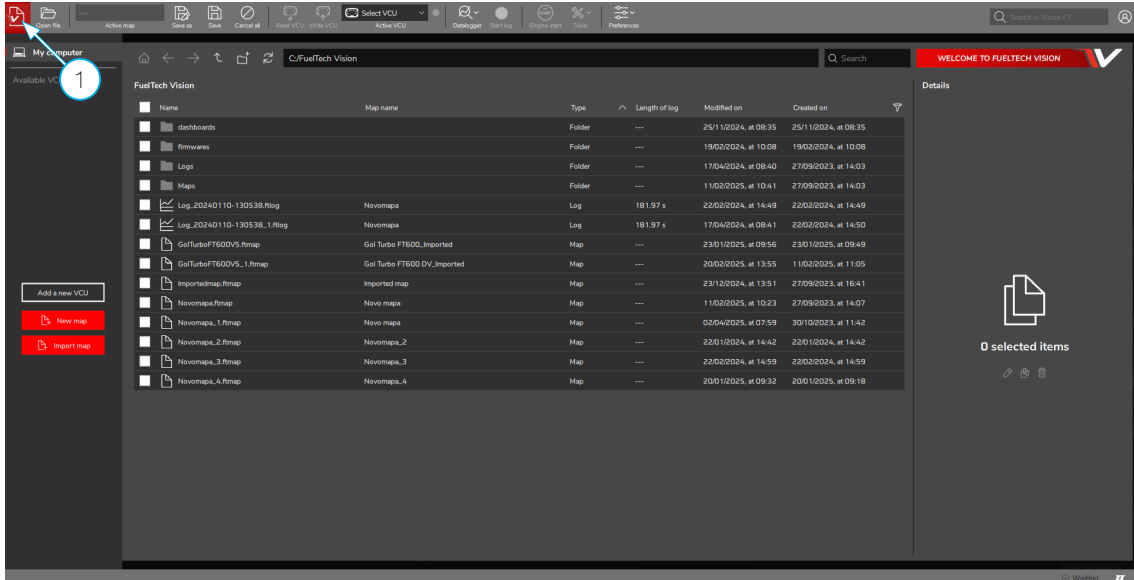



# **INTERFACE**

Settings



## 24. Interface settings

Here are the settings related to the interface like measure units, buzzer sound, LCD backlight, etc.

### 24.1 Day/night mode

There are 4 options to select.

**Day mode:** adjust brightness the display to value in LCD backlight settings menu.

**Night mode:** adjust brightness the display to value in LCD backlight settings menu.

**Dashboard:** Enable button on dash to control mode.

**External switch for dark mode:** this option is necessary configure a white input with vehicle light switch.

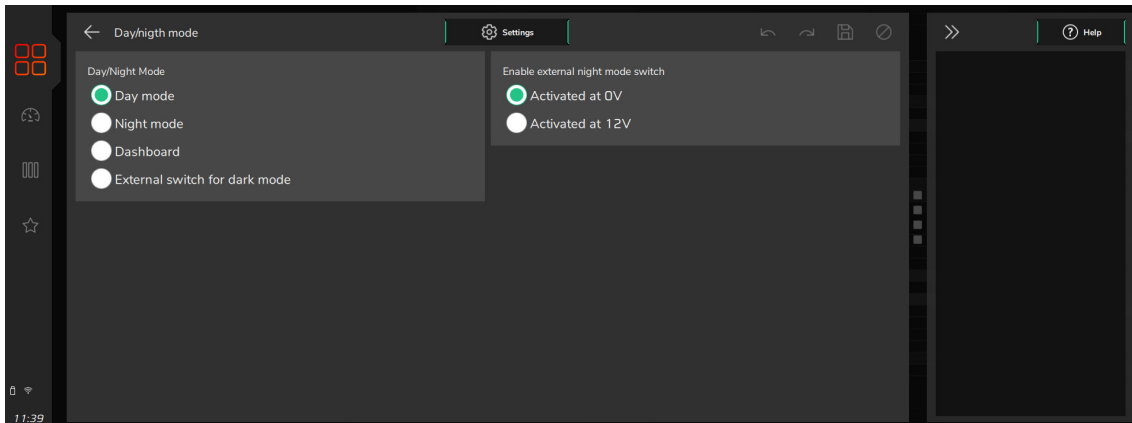

### 24.2 LCD settings

Adjust LCD brightness and select between night and day modes.

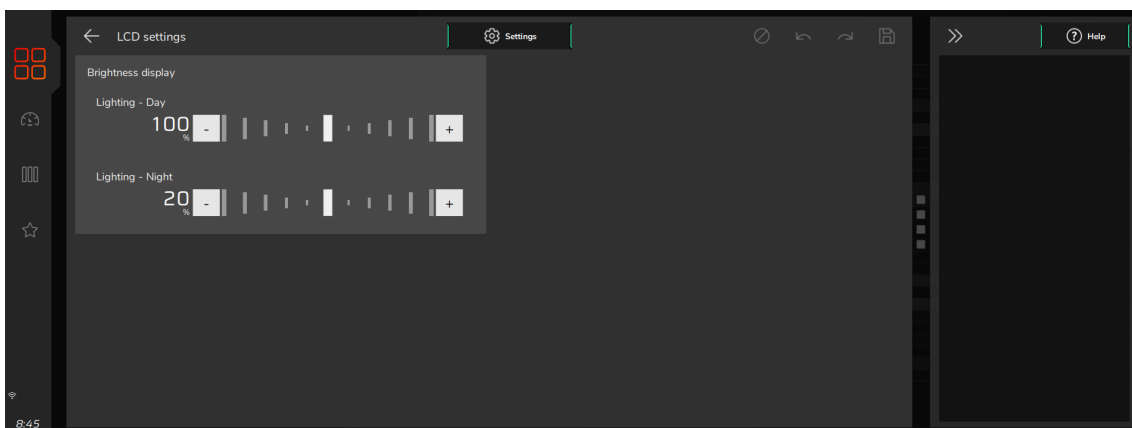

### 24.3 LED configuration

This function allows you to configure all optional LED's

#### Top LED

Select here the options on how the shift light LEDs will work. It is possible to set the LEDs to turn on in a fixed RPM, progressively or with different values by gear.

**Single value:** select the LED you want to edit, choose its color and the RPM value to activate it.

**Gear based:** select the LED to edit, choose its color, set the RPM you want it to turn on for each gear and which LEDs will be activated.

**Warning signal mode:** Configures how the LEDs will behave at the speed limit.

- **Always on:** the LEDs will remain on until the RPM drops below the configured value.
- **Blinking:** The LEDs will blink until the RPM drops below the configured value.

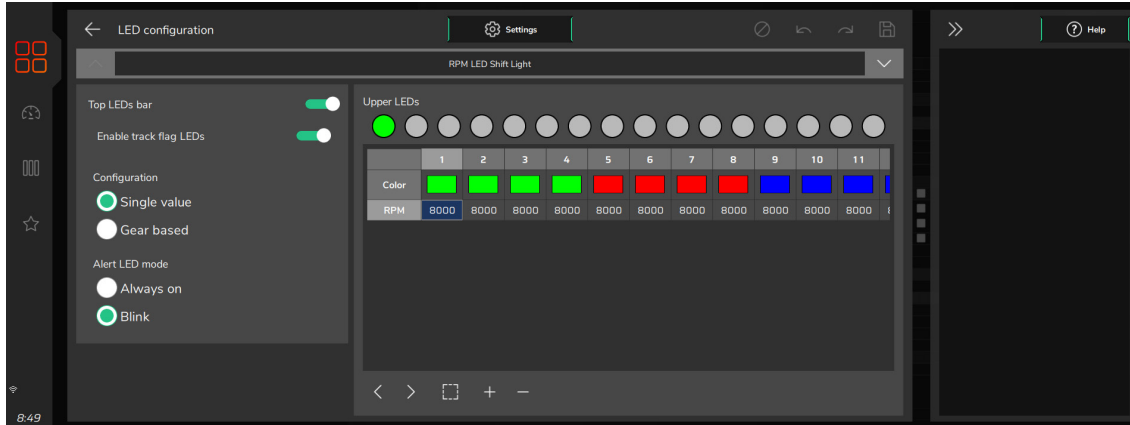

### Side LEDs

It is possible to set side LEDs choosing from up to 52 alerts options.

**Color:** Select the LED color.

**Warning mode:** This menu has two options; always enabled or blinking;

**Condition:** Select the function will be associated to this LED.

- **Activation mode:** set the maximum and minimum values to turn the LED on.
- **Operation 2 and 3:** This option provides more activation conditions to the same LED.

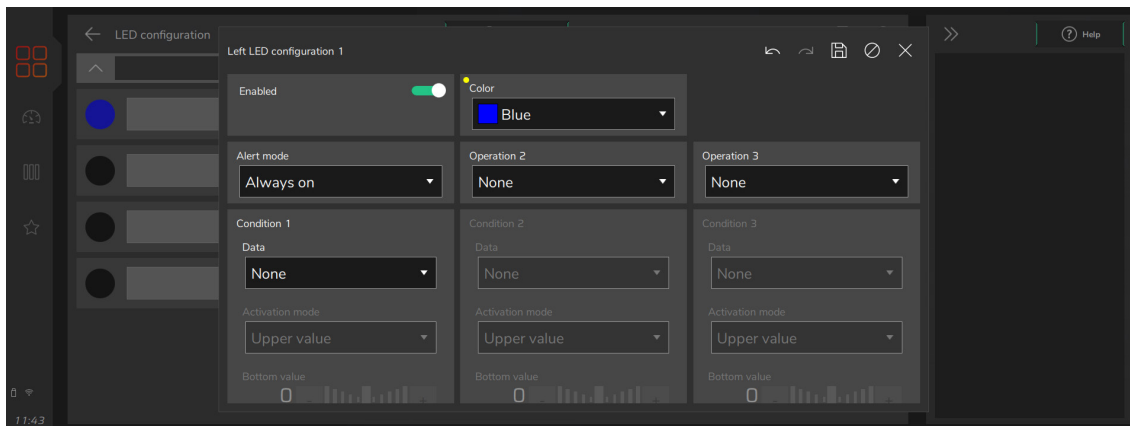

## 24.4 Sound settings

This parameter allows for setting the volume of sounds generated by touching the display. When the mute option is selected, the ECU is silent when the screen is touched.

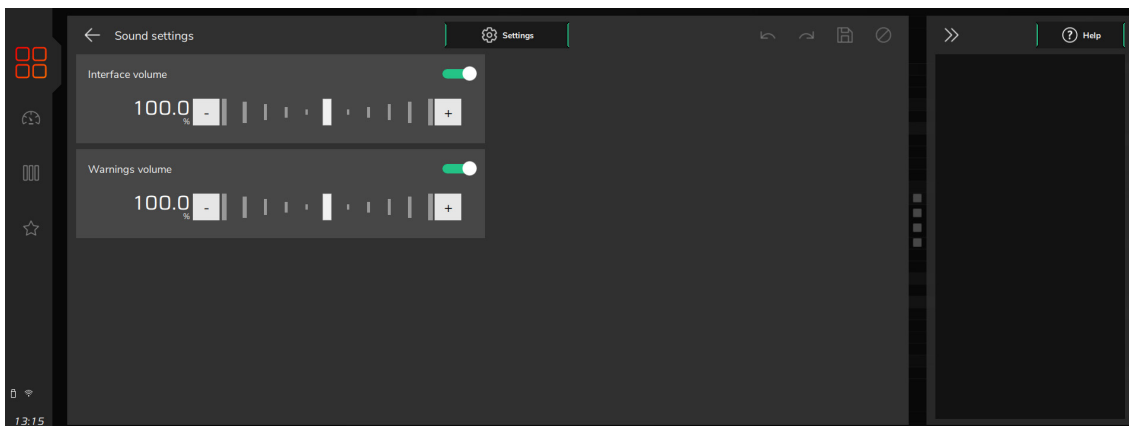

## 24.5 Dashboard setup

The Dashboard displays information in real time. The FT700's screen is fully configurable, it is possible to mix pointer instruments with digital ones, with numbers and bars, squares with round ones, all with an interface designed to be easy and editable.

**Dashboards quantity:** You can configure up to 4 dashboard screens

**Dashboard type:** There are two options “Custom” and “Fixed”

**Custom:** Allows you to create your own dashboard

**Fixed:** In this option there are several dashboards ready for use, including some cars from Anderson Dick!!!

**Dash settings:** when selecting the customized option, it is necessary to click on the configure button to access the dashboard editing area.

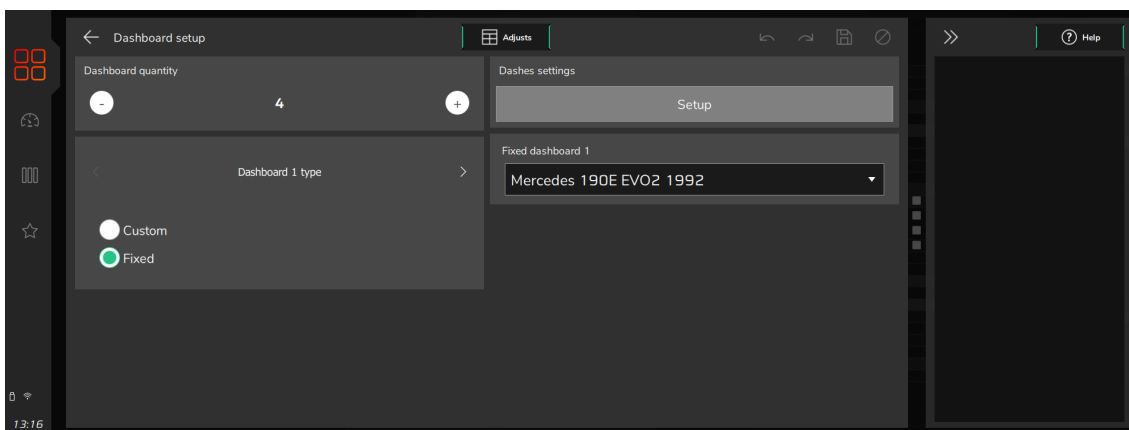

## Dash configuration

Editing the dashboard is performed through the menu (1). This menu is divided into three parts:

**Top bar:** Buttons for adding and removing components

**Information / Model / Style:** It's possible to edit the component already included in the dash and change the model and style information of each one.

**Bottom Bar:** It's for positioning the component on the screen as well as changing its size and display limits.

- 1 - Edit menu
- 2 - Component inclusion
- 3 - Component removal
- 4 - Grid

- 5 - Back
- 6 - Save
- 7 - Position: fine-tune the positioning of the component
- 8 - Size adjustment: increases or decreases the component size
- 9 - Component configuration: This button configures the minimum and maximum values as well as the number of decimal places and divisions and also the behavior of the component in alert/safety mode.

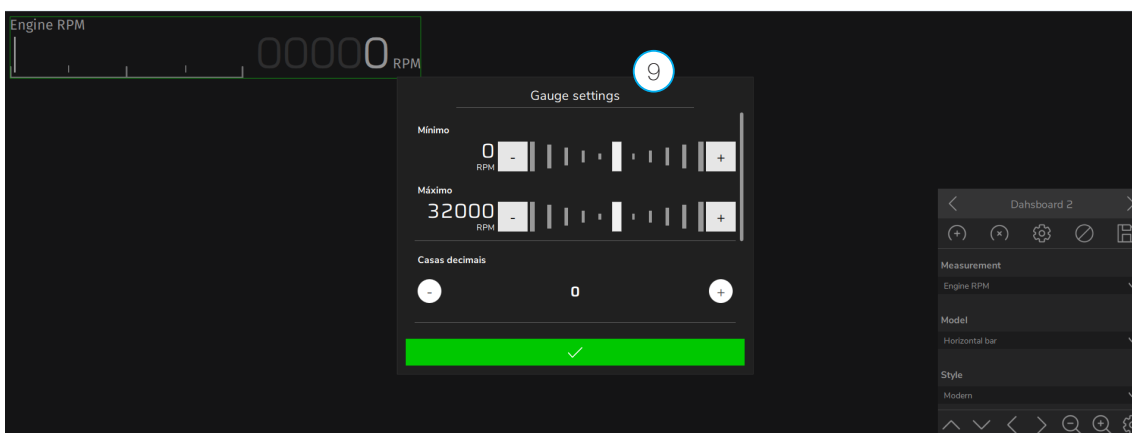
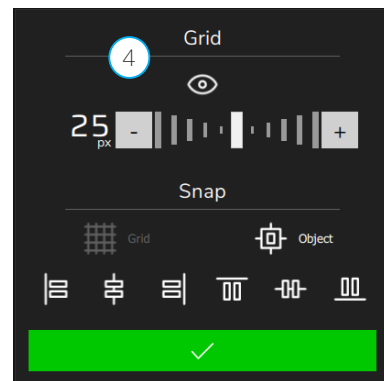
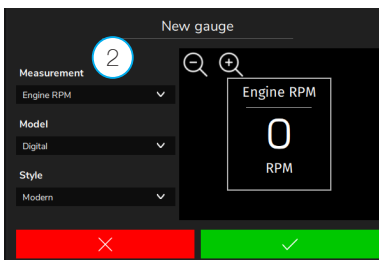

## Dash configuration using VisionFT

By using the FuelTech Vision software it's possible to configure dashes for all platforms in one place. The editing mode follows the same pattern described on the previous page.

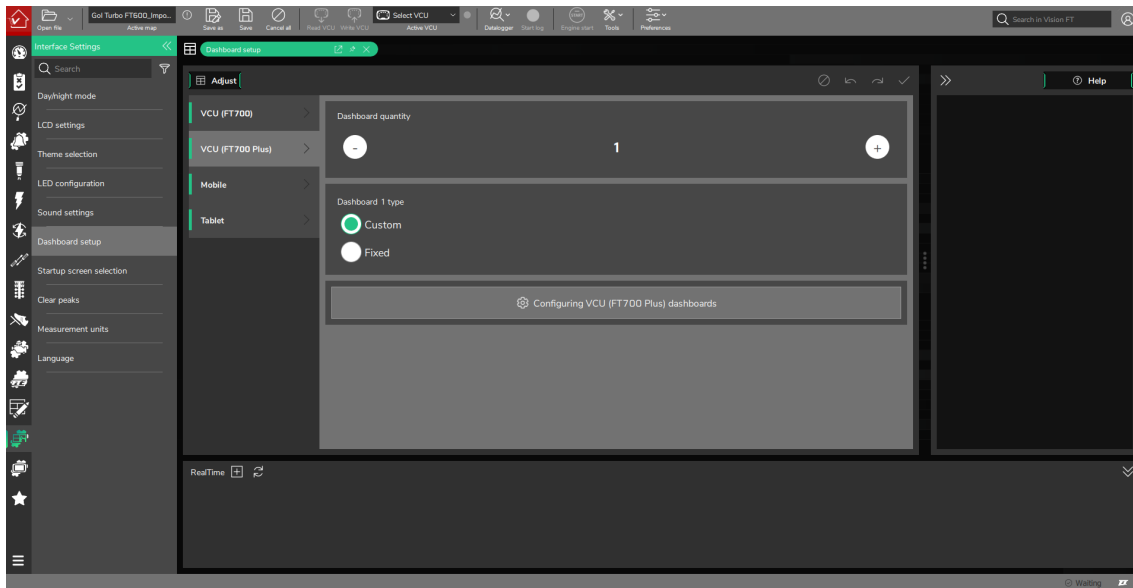

For the mobile (smartphone) and tablet version, it is necessary to adjust the orientation (vertical or horizontal) and define the width and height of the screen so that the information is correctly configured on the screen.

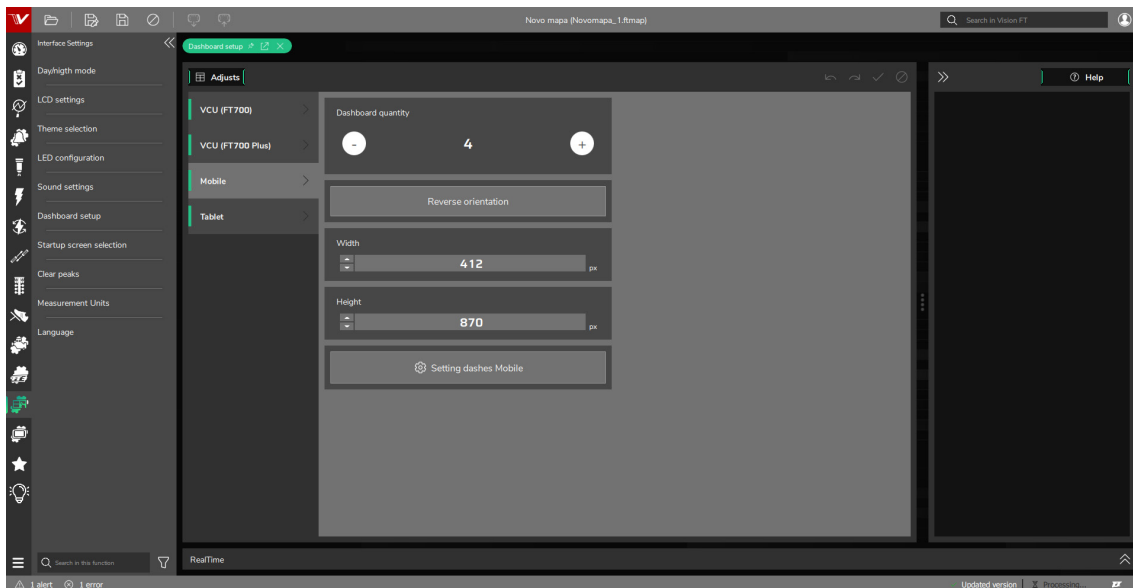

## 24.6 Startup screen selection

Select the screen shown right after the ECU is turned on. In case the option “Open the main menu after startup” is selected and the ECU is set up with a user password, the ECU will ask for the user password.

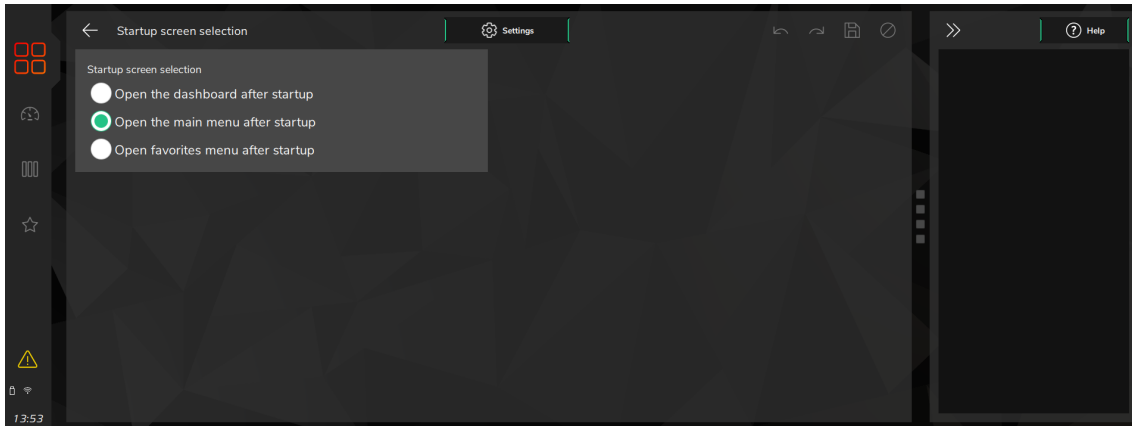

## 24.7 Measurement units

In this menu it is possible to change the measurement unit for some parameters as pressure, temperature, speed and O2 readings.

**Pressure Units:** bar, PSI

**Temperature units:** °C or °F

**O2 sensor units:** Lambda, AFR Gasoline

**Speed units:** km/h or mph

**Flow unit:** l/min, l/h, cc/min

**Volume:** L or Cl

**Shock travel:** mm or in

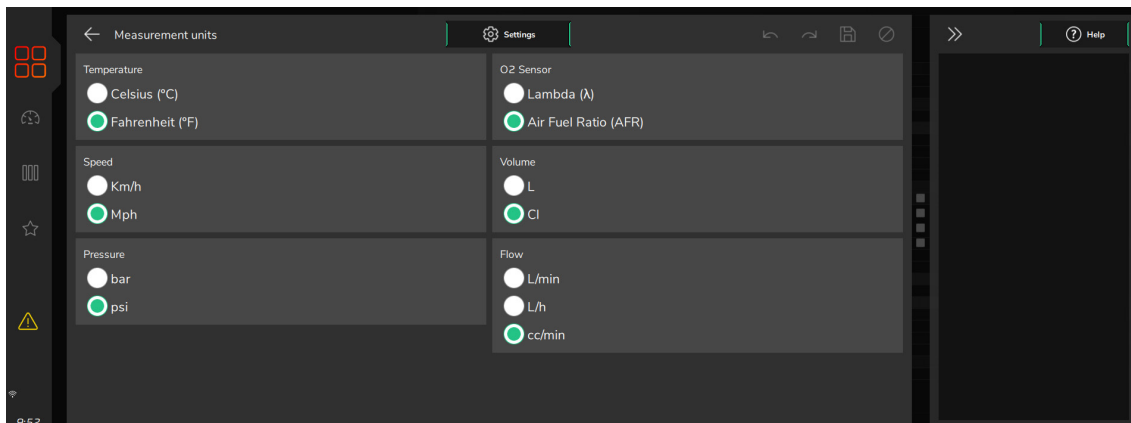

## 24.8 Language

FT700 it's possible to change the interface language. There are many languages available, Portuguese, English, Spanish, Deutsch, French and Italian. Just select the option and all the software will be adjusted to the new language, including the measurements will also be changed to the default for each language.

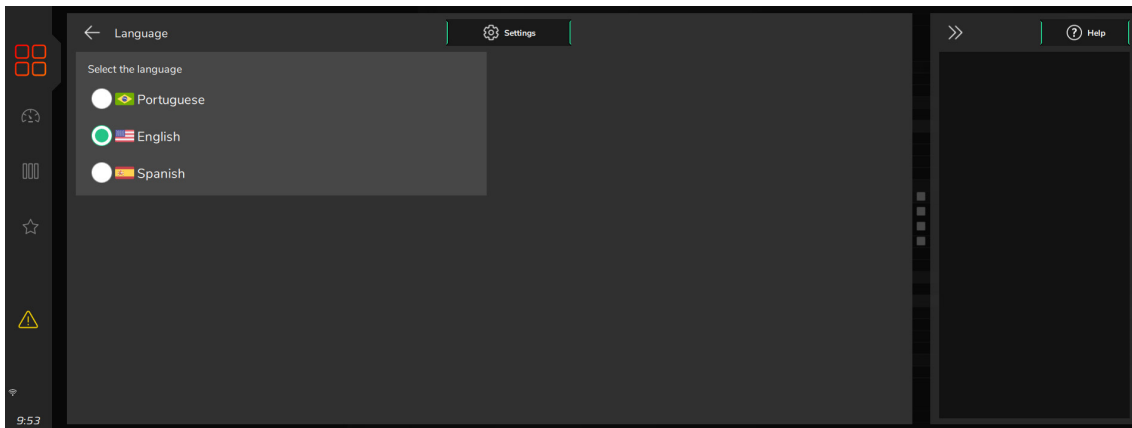

## 24.9 Theme selection (VisionFT software)

For the FuelTech Vision software, you can change the screen colors as you wish.

**Theme selection:** there are four options to choose from;

- **Dark (default);**
- **Light 1;**
- **Light 2;**
- **Custom:** when selecting this mode, a screen will open on the right with the standard colors and their respective codes. Double-click on the color you want to change to open the color palette. Create your favorite combination!!!!

**Menu color:** sets the menu color to fixed or if it will follow the customized theme.

**Restore defaults:** button that returns to the standard color configuration (Dark theme).

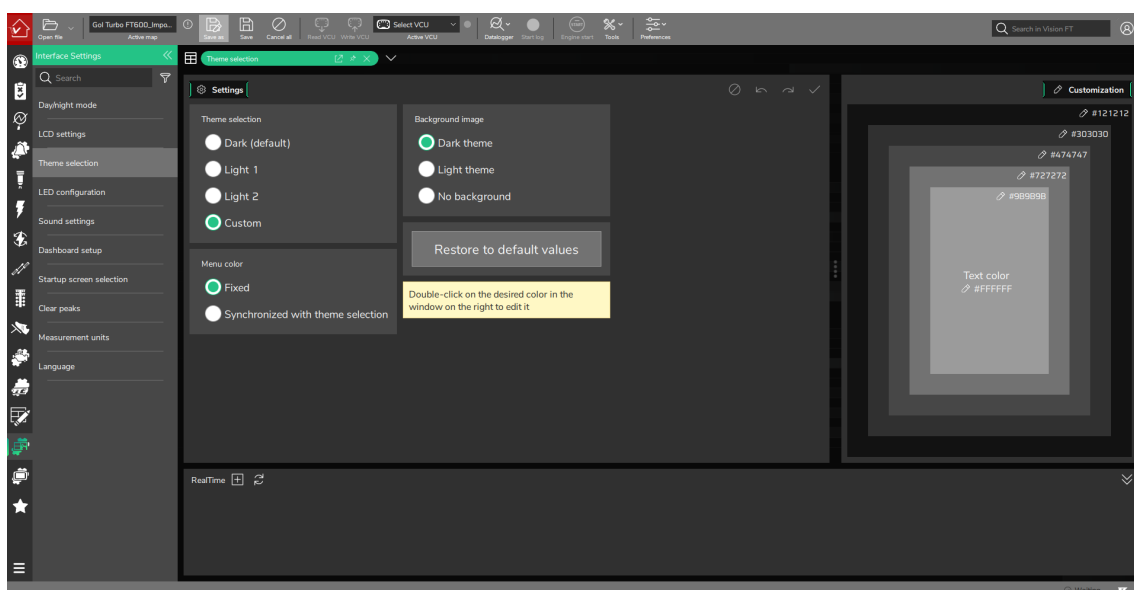

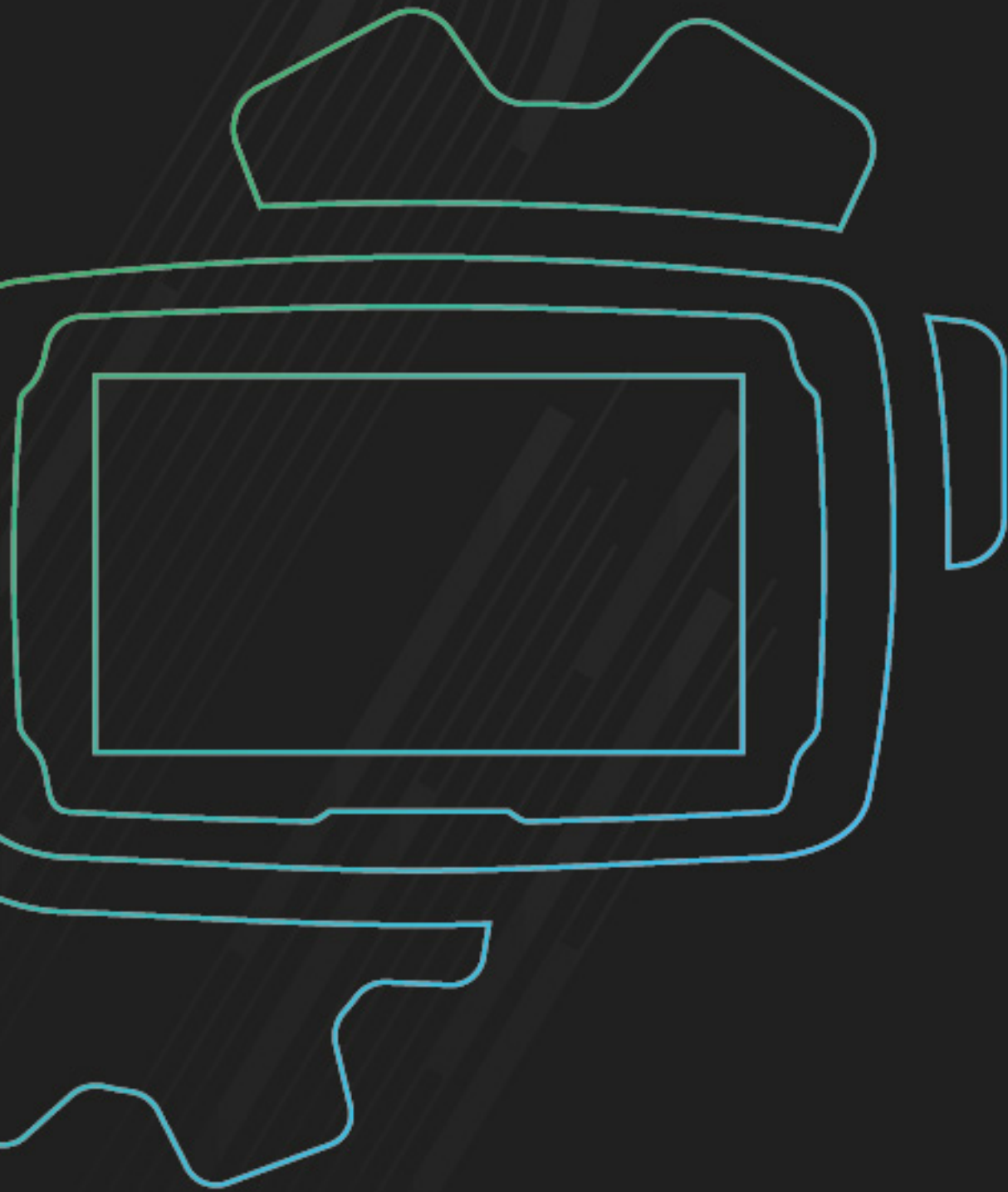

***VCU***  
Settings



## 25. VCU Settings

This menu contains all the connectivity, security, registration and important numbers for version control functions of the VCU.

### 25.1 Inputs

This is all the information that the VCU receives through sensors spread throughout the vehicle. For example, pressures, temperature, positions, frequencies, speeds, buttons, etc.

These settings are available for each sensor to be configured. To do this, access the sensor, click on the “input sensor” button and then click the input configuration screen.

#### Input configuration

**Channel name:** Select the type of reading for the selected input. If the desired reading/sensor is not in the list, select the “Custom” option. When selecting “Custom”, it is necessary to enter the name of the reading created and the name to be displayed on the panel, with the respective reading unit (bar, °C, rpm, etc.).

**Offset:** adds an offset to the selected reading to compensate reading differences

**Offset type:** offset value can be added after the conversion (in °F, psi, etc.) or before the conversion (in Volts). Select the option that suits better in your case.

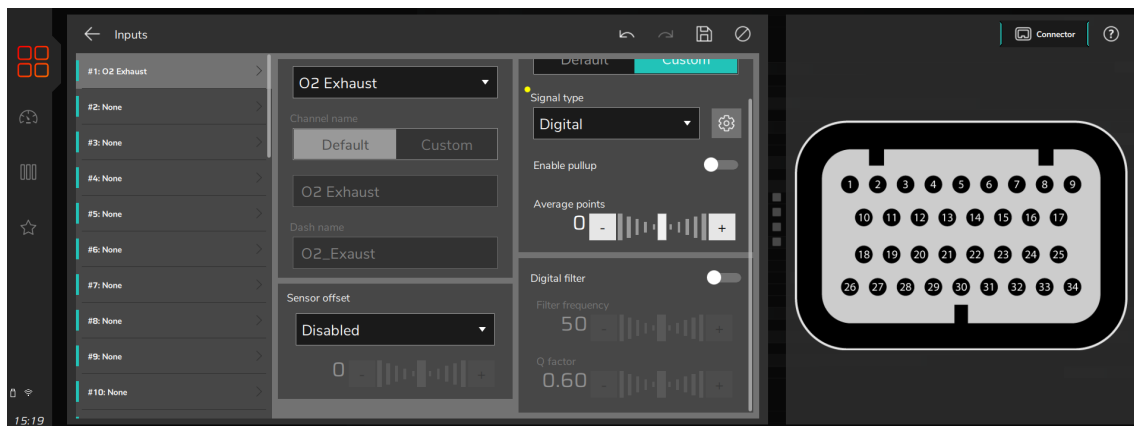

*Digital filter:* Enables a filter on the input reading.

*Filter frequency:* select the frequency of the digital filter. Standard value is 50.

*Q Factor:* filter quality factor. Standard value is 0,60.

#### Input sensor

**Default:** Select this option when reading standard FuelTech sensors (PS-10B, PS10-A, PS-20B, etc.). If you want to read a different type of measurement, which is not registered in "Channel name", but using a predefined sensor, set the channel name to "Custom" and enter the reading name and unit, then select the compatible sensor.

**Custom:** Select the “Custom” option for cases where the sensor used is not in the predefined list.

Signal type: There are six options in this menu.

Analog (0-5V sensors)

Digital (logic 0 and 1 sensors – buttons, RPM and speed)

Frequency

Speed

Duty cycle

Position relative according trigger wheel

Enable pull-up: Pull-up is a type of connection that keeps the input signal at 5V when it is not activated. For example, the two-step button is activated by the negative signal, when it is deactivated the signal remains at 5V.

It is recommended to only deactivate pull-up in cases where the FuelTech module is sharing the sensor reading with the car's original ECU, as it already has an active pull-up. Example: When sharing the TPS signal from the electronic throttle, the car's original temperature sensor, etc.

Average points: Corresponds to the number of points read in a given time interval. The higher the value set, the more "smoothed" the signal will be in the log. Values around 60 are recommended for sensors with little variation in a short time interval. Example: air temperature sensor.

For readings that vary more quickly in short time intervals, values around 7 can be used. Example: Lambda probe signal and pressures.

Options for digital sensor: This menu is only available when using a digital sensor. This configuration is recommended in cases where you want to connect a button or capture the rotation/speed signal.

## Digital configuration

**Higher level:** When the input voltage exceeds the value set in the "Hi level (V)" menu, the input is considered activated.

**Level with hysteresis:** In this option, the "hi level" and "lo level" menus are available, and the input is considered activated when it is above the value configured in the "hi level" and remains so until the voltage is lower than the value configured in the "lo level".

**Automatic level:** In automatic mode, the 0V signal will be considered activated and the signal other than zero will be considered deactivated. Example: Two-step, where it is activated by the negative signal.

**Invert output signal:** only available on Level with hysteresis and Automatic level modes, this option makes the output be "active" when voltage is 5V and "deactivated" when voltage is 0V.

Interpolation table: this table is available when using a customized analog sensor. Insert here values of voltage X output signal.

**Fill values:** when using a linear analog sensor, insert the first and last values of the voltage X output signal on the table and click this button.

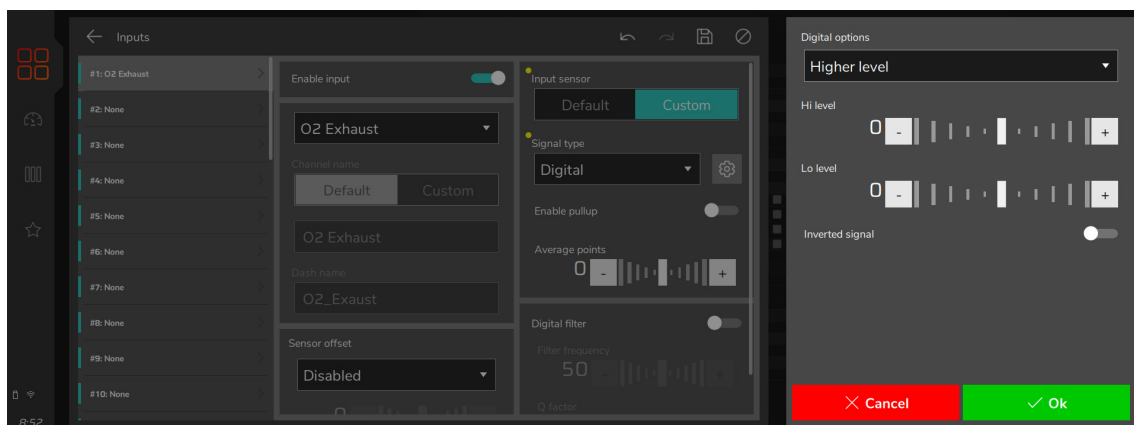

## 25.2 Outputs

Outputs are the actuators configured in the VCU such as injectors, coils, valves, LEDs, etc. Since the VCU outputs can be configured in several ways and perform different functions, they have different capabilities depending on the application.

**Blue outputs:** by default, they are automatically configured as injection outputs. During the configuration of the engine settings, the injection outputs will be automatically filled from blue 1 to blue 16. When more than 16 injector outputs are needed, the ECU will use Gray outputs or Yellow output. In this case, the use of a Peak and Hold driver is mandatory on Gray and Yellow outputs (for saturated and low impedance injectors).

Blue outputs not used to control fuel injectors may be used as auxiliary outputs (controlling fuel pump, cooling fan, etc.). In this case, the use of a relay is mandatory.

**Gray outputs:** by default, they are automatically configured as ignition outputs. They can be configured as injection or auxiliary outputs, as needed. During the configuration of the engine settings, the Ignition outputs will be automatically filled from gray 1 to gray 12 and for engines with more than 12 cylinders, yellow outputs can be used for ignition. The gray outputs that will not be used for ignition can be used to activate injectors (the use of Peak and Hold is mandatory for high or low impedance injectors) or as auxiliary outputs (the use of a relay is mandatory).

**Yellow outputs:** by default, they are used as electronic throttle control (yellow 1 and 2) or stepper motor control (yellow 3 to 4). The yellow outputs that will not be used for electronic throttle control can be used as auxiliary outputs or for injectors. When using injectors for the integrated BoostController, the output can be connected directly to the injector, but when using injectors for fuel, the use of a Peak and Hold driver is mandatory for both high and low impedance injectors

Next to each output there is a TEST output button, this button activates the output with a 3ms pulse. This function allows you to test the outputs to identify whether the pulses are leaving the ECU correctly and reaching the actuator. This option also helps to identify the specific injection and ignition outputs for each cylinder.

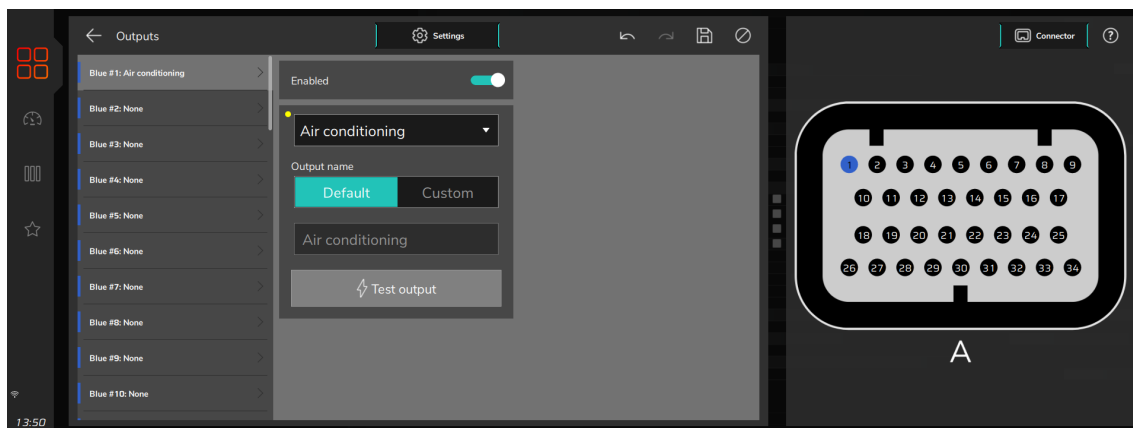

### 25.3 Wi-fi

For this connection it is necessary to first place the VCU on the same network as the desktop.

a - On the VCU menu screen, access the “VCU Settings” function (1).

b - Click on the “Wi-fi” function (2) to open the settings.

c - Within the Wi-fi function settings there are two “Wi-fi operation modes”:

- **Device mode:** lists all available Wi-fi networks in the location. When choosing this option, all devices must be on the same network to work.

- **Access Point mode:** in this mode an exclusive network is created for connection between the VCU and the connecting devices, in this case it is necessary to configure the network name and password.

d - After connecting to the chosen Wi-fi network, you need to connect to the device. To do this, open the side menu on the VCU by clicking on the icons (3) and after clicking and holding the Wi-fi button (4), a screen will open with the password for pairing the two devices. Enter this password on the device you want to connect to the VCU and the connection will be executed automatically every time as soon as the software is opened.

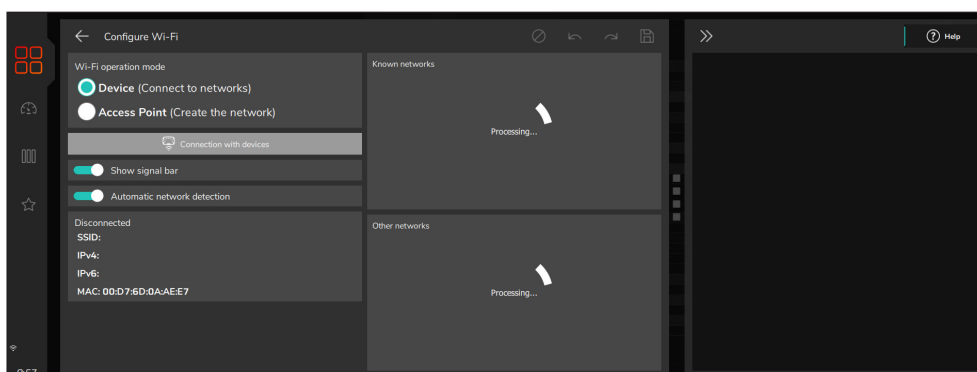
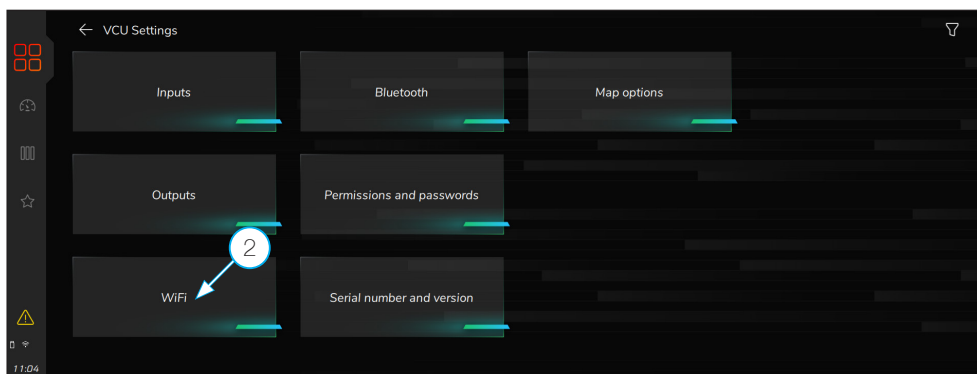

## 25.4 Connection with USB network adapter

This function allows to setup a USB network adapter. It's necessary to include some parameters.

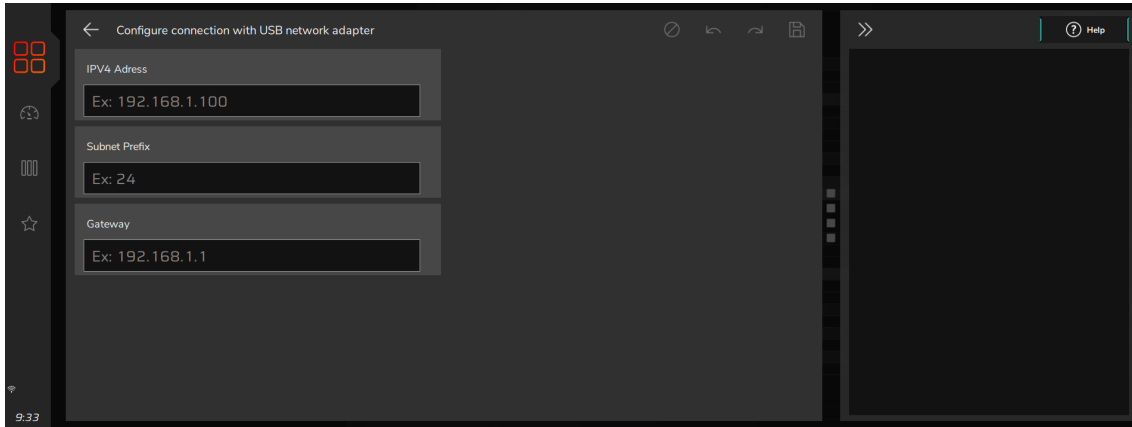

## 25.5 USB

There are two options for connecting the rear USB port.

**Host:** This is the VCU that controls communication and manages peripherals connected via USB. Typically, a host provides power and initiates communication with the connected device.

**Device:** This is the peripheral equipment connected to the host. It receives power and responds to commands from the host.

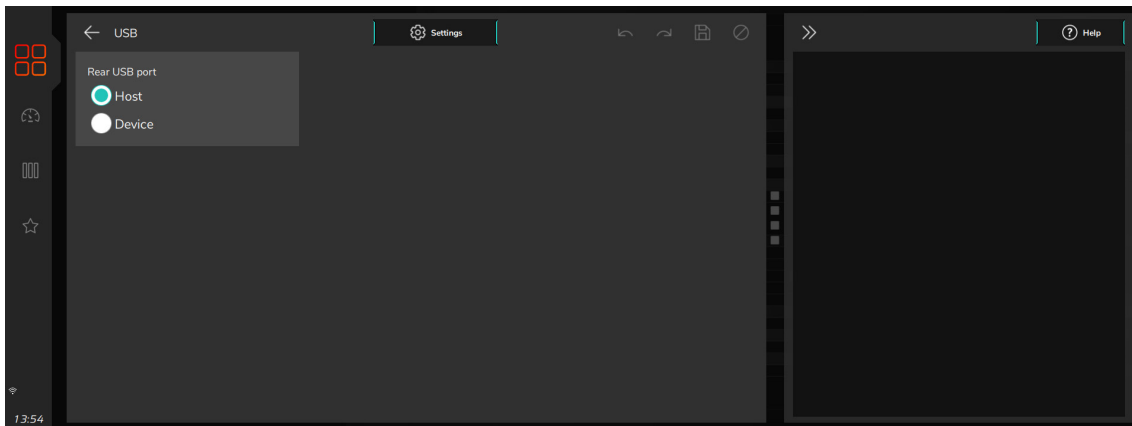

## 25.6 Passwords and permissions

This function allows you to set a password for the map used.

**Map password:** This password blocks all the map menus of the fuel and ignition table adjustments, engine settings, aux function and file manager. Alert settings, shift alert, display and initial screen are left unprotected. When this password is enabled, it's not possible to change any ignition or fuel maps. The FTManager software access is also blocked by the

**Map protect map by serial number:** creates a password linked to the VCU serial number.

**Access permissions menu:** lists all active VCU functions and allows blocking of the entire group or only specific functions.

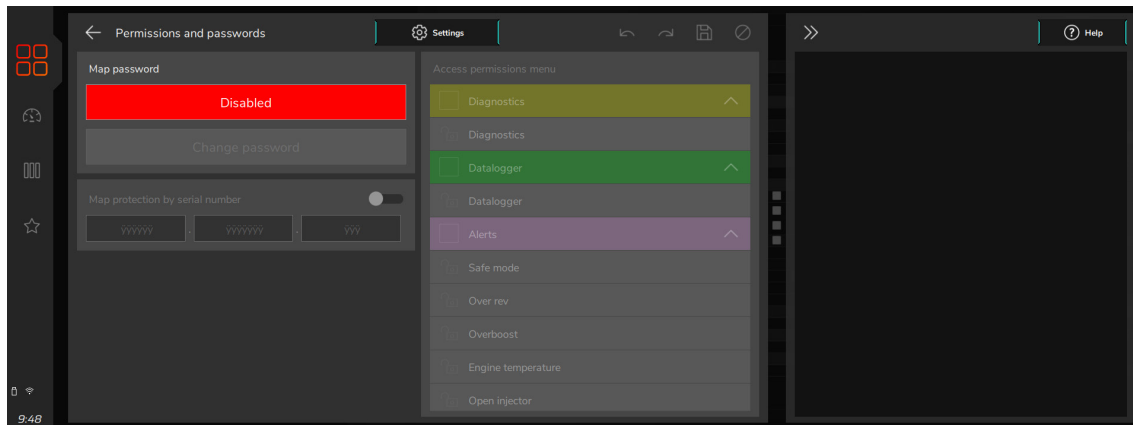

## 25.7 Single identifiers

This feature creates single identifiers to more quickly access a VCU

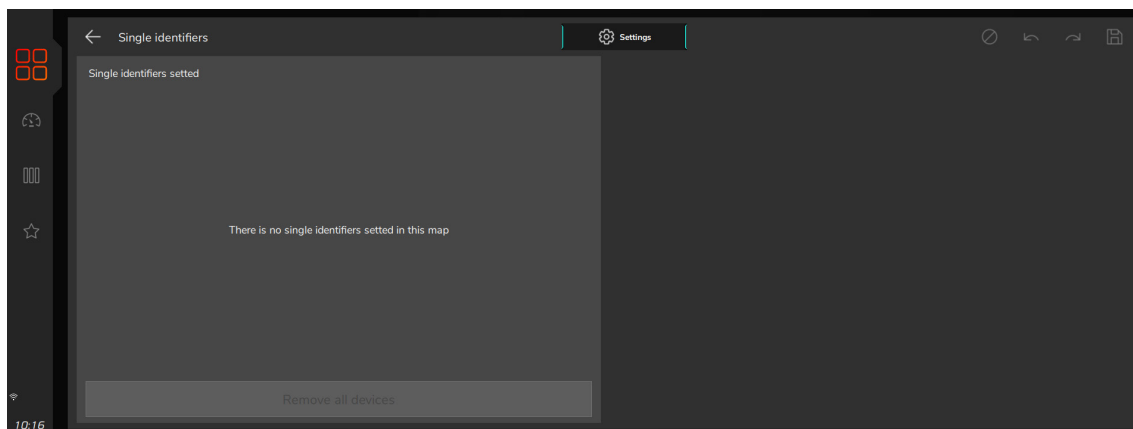

## 25.8 Identification information

It allows you to create an identity for VCU as well as a test driver in the car.

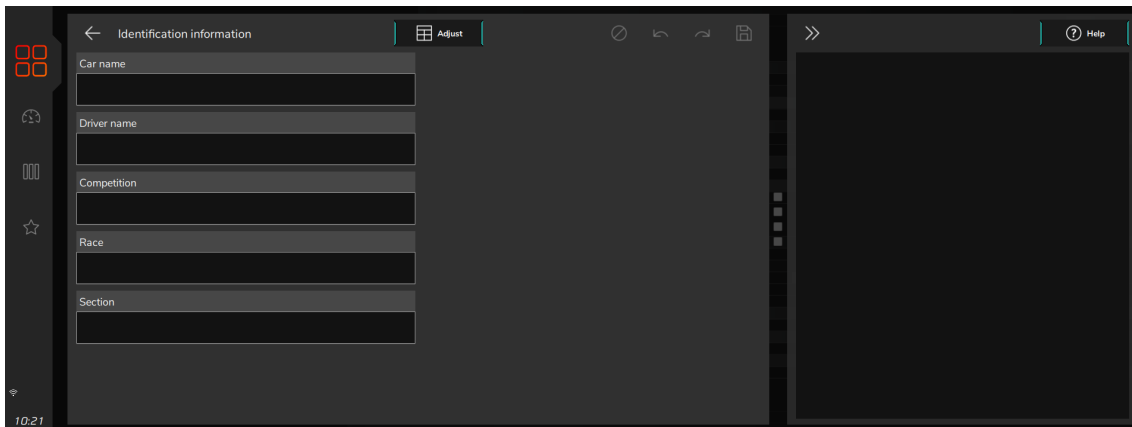

## 25.9 Serial Number and Version

Displays the serial number and version of the VCU



## 25.10 Map options

This option shows all the functions that are available in the VCU, both active and inactive. You can activate/deactivate the function by clicking on the button (1) and also place the function in the favorites menu using the button (2).

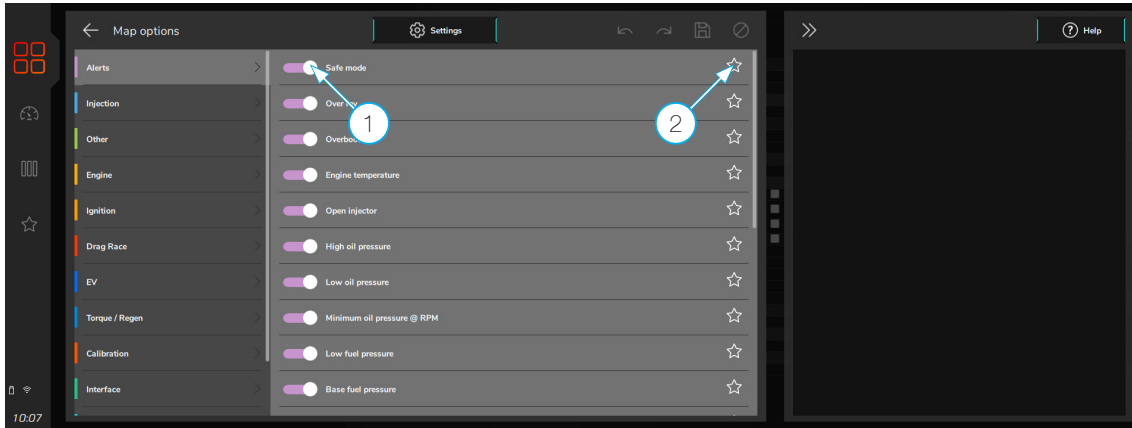

There are other options to activate functions directly without having to enter the map options.

- Access the functions menu
- Leave the filter (3) disabled to show all functions
- Click on the function you want to activate and hold it until the menu (4) appears, then activate/deactivate the function and also favorite it if necessary.

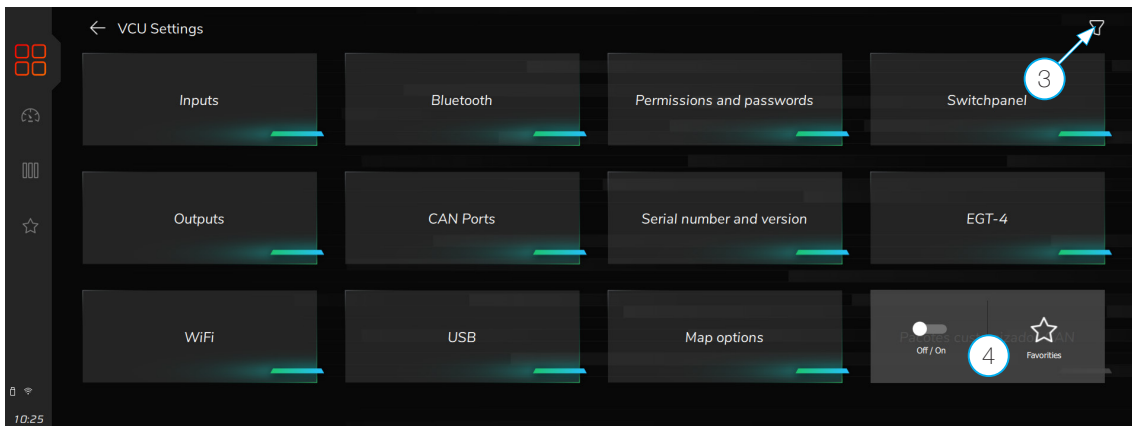

## 25.11 CAN Ports

This function allows you to configure completely independent CAN networks. There are four CAN networks in total, and they all have the same settings.

**Operating mode:** allows you to choose between two modes, Standard and FTCAN 2.0

- **Standard:** used for customized packages
- **FTCAN 2.0:** uses the same CAN protocol as the Power FT line.

**Baudrate:** adjusts the data transmission speed on the CAN network

**FD mode:** enables the FD CAN network data packet

**EV mode:** enables the EV CAN network data packet for use in electric vehicles

**FTCAN 2.0:** activates real-time or simplified data packet

**Product identifiers:** allows you to use the product identifier for the Power FT line

**Unique identifier:** this value is used to uniquely identify the products on the CAN network. For example: If there are two FT700 VCUs on the same CAN network, this value must be adjusted so that both can be recognized on the network.

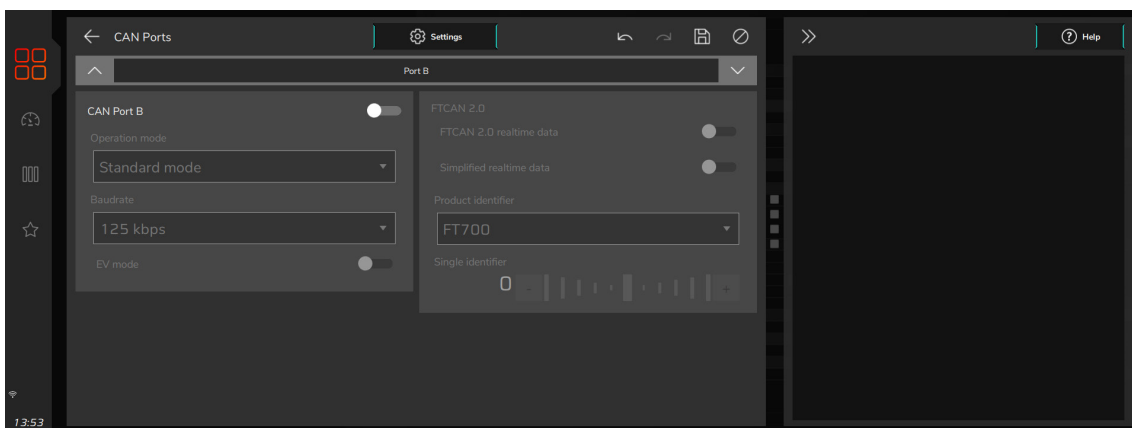
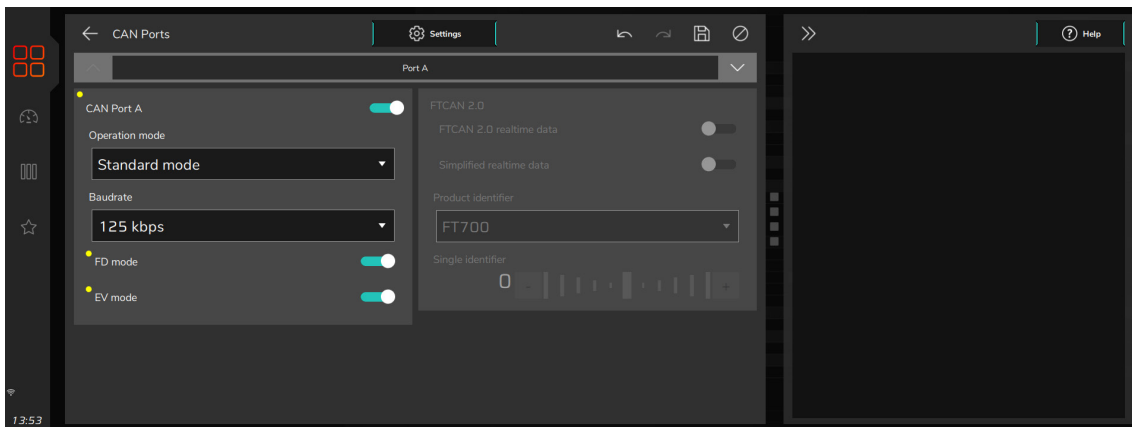

## 25.12 Customizable CAN

This function allows you to create message packages that will be used on the CAN network. There are 16 message configuration boxes, allowing a large number of possible information to be configured.

**Name:** defines a name for a message group.

**ID:** assigns a hexadecimal code to the message group.

**Bytes:** adjusts the message size, up to 8 bytes can be configured.

**Period:** is the frequency with which the group will be sent on the CAN.

**Direction:** defines whether the group will be sent and received by devices connected to the CAN.

**Port:** adjusts which port is used on the CAN

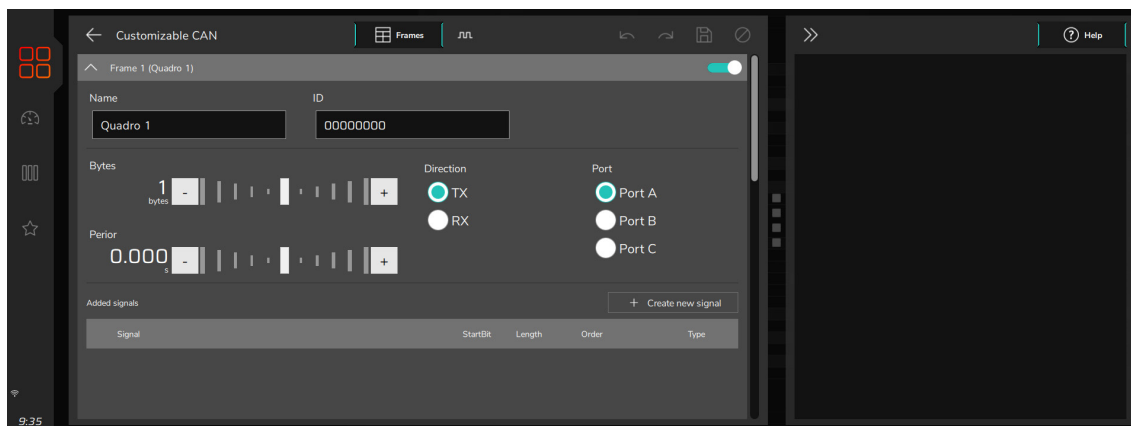

## Signals

Configures the messages that will be sent on the CAN network

**Name:** Defines a name for each signal.

**ECU Channel:** Selects which information will be transmitted.

**StartBit:** Initial position of the signal in the message.

**Length:** Defines the number of bits of the signal in the message.

**Scale:** Adjusts the scale of the signal.

**Offset:** Adjusts an offset value if any.

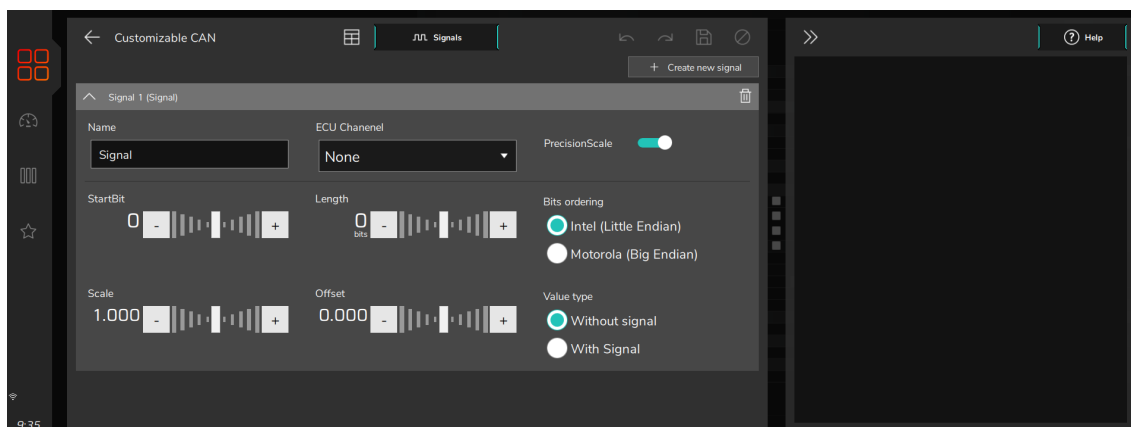

### 25.13 CAN Custom Packages

This function allows you to configure specific packages for different products. Please contact technical support for more information.

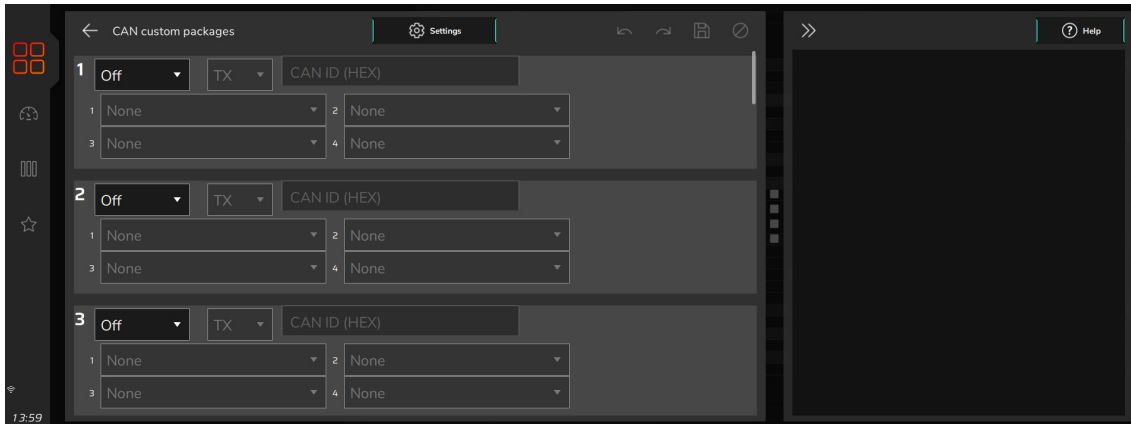

### 25.14 SwitchPanel

Allows you to configure the SwitchPanel buttons. You must first activate which panel will be used, as well as which CAN network it is connected to.

On the next screen, you must configure the functions for each button on the panel.

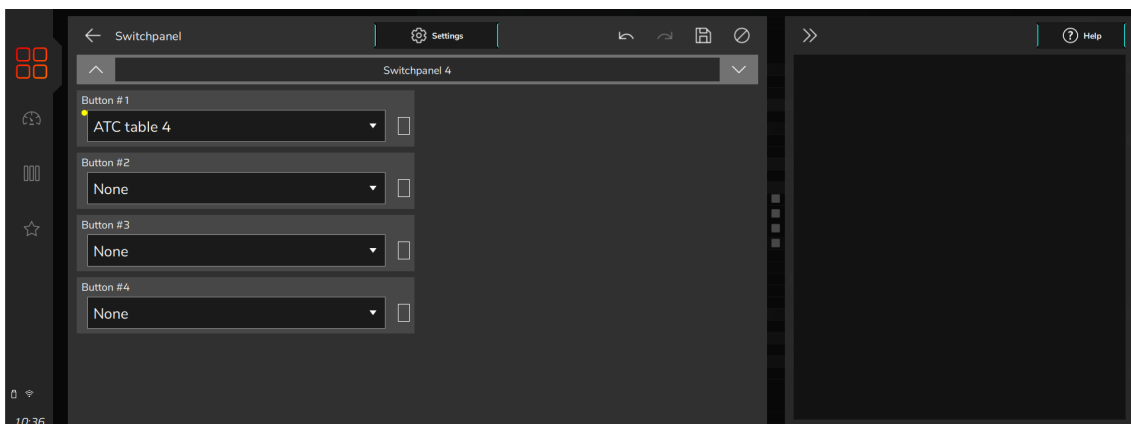
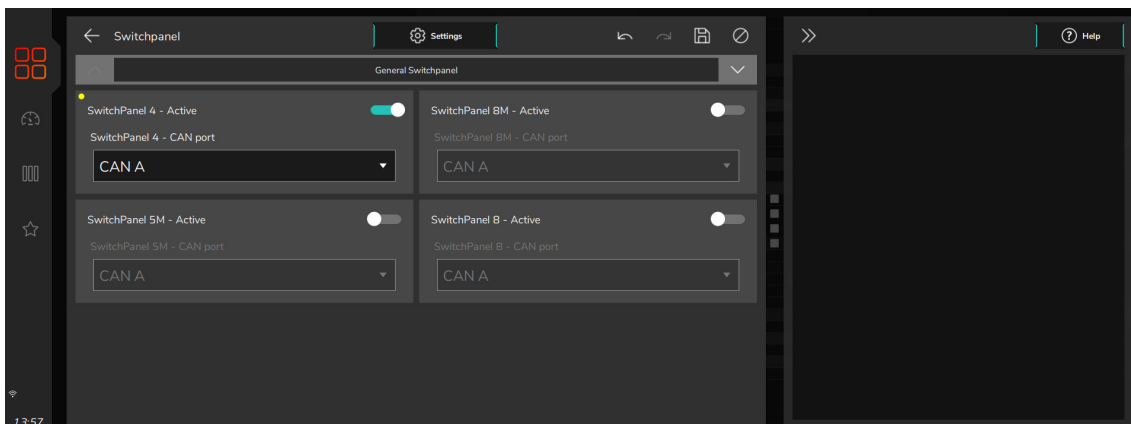

## 25.15 EGT-4

Allows you to configure EGTs. You must first activate which panel will be used, as well as which CAN network it is connected to.

On the next screen, you must configure the functions for each EGT output.

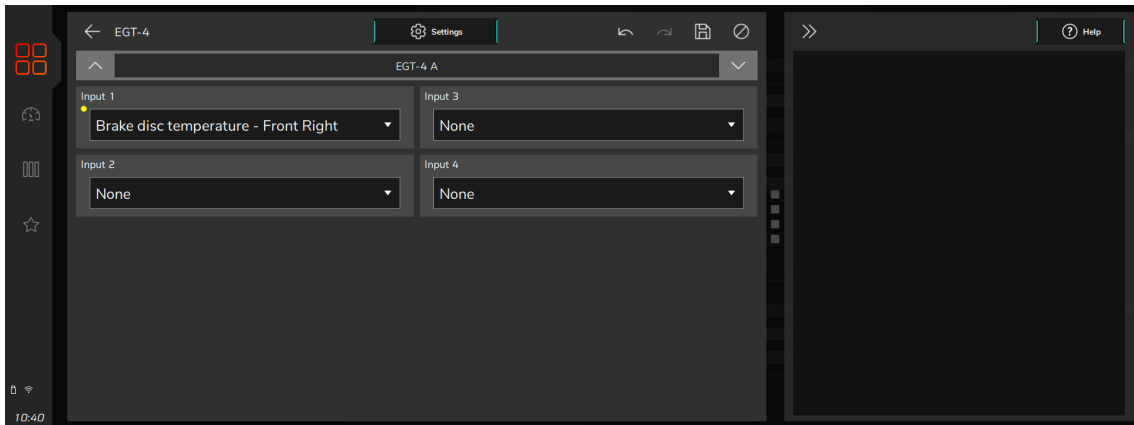
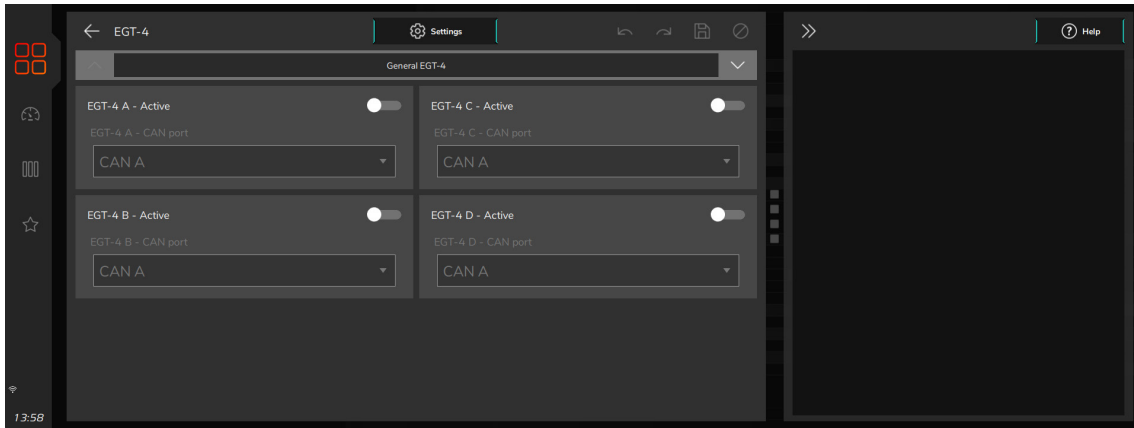

## 25.16 Racelink

Adjust the FT CAN data packages for the Motec or Racelink operating mode

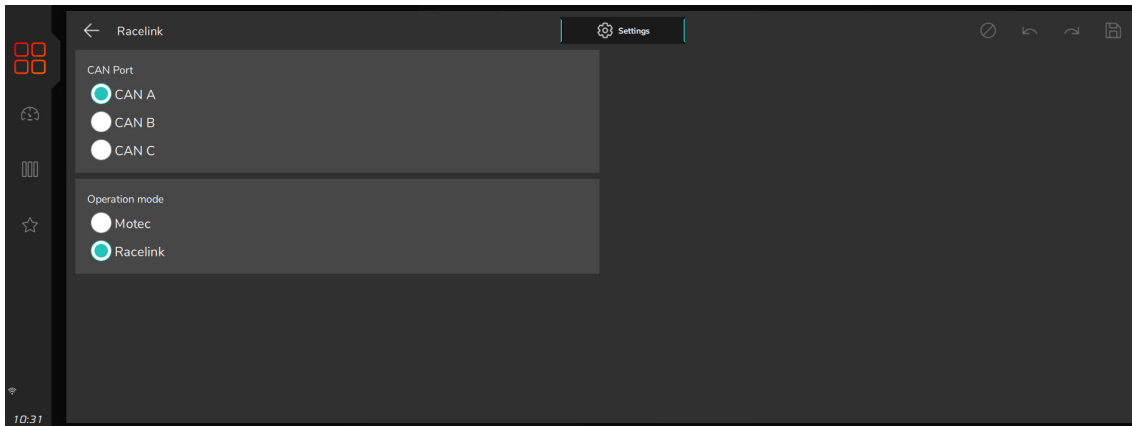

## 25.17 Steering wheel

Configure which VCU CAN network will be responsible for sending information to the steering wheel

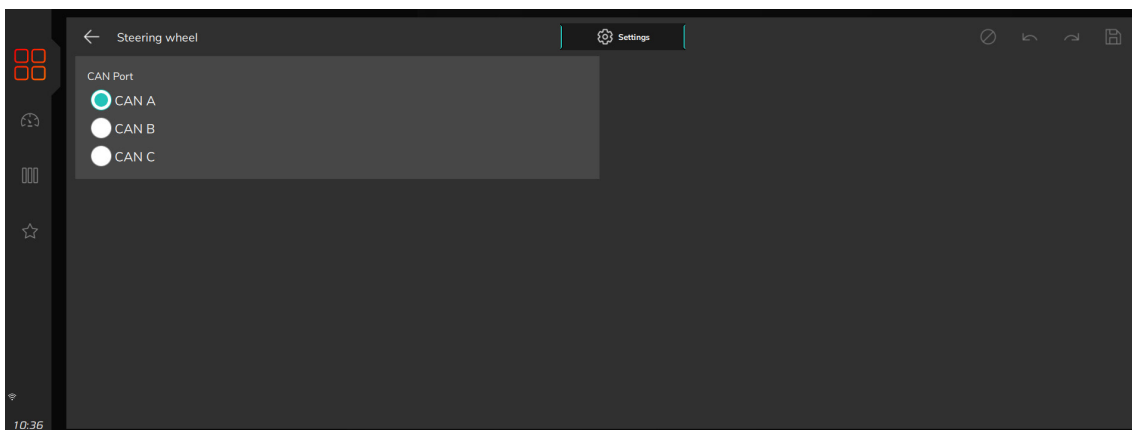

## 25.18 IP cameras

This function makes it possible to configure two cameras with IP communication, without needing a specific pin for connection to the FT700.

**Camera - Name:** defines the name of the camera on the network.

**Camera - URL:** configure or address IP for access.

**Activation mode:** there are two options, always active or active with reverse gear.

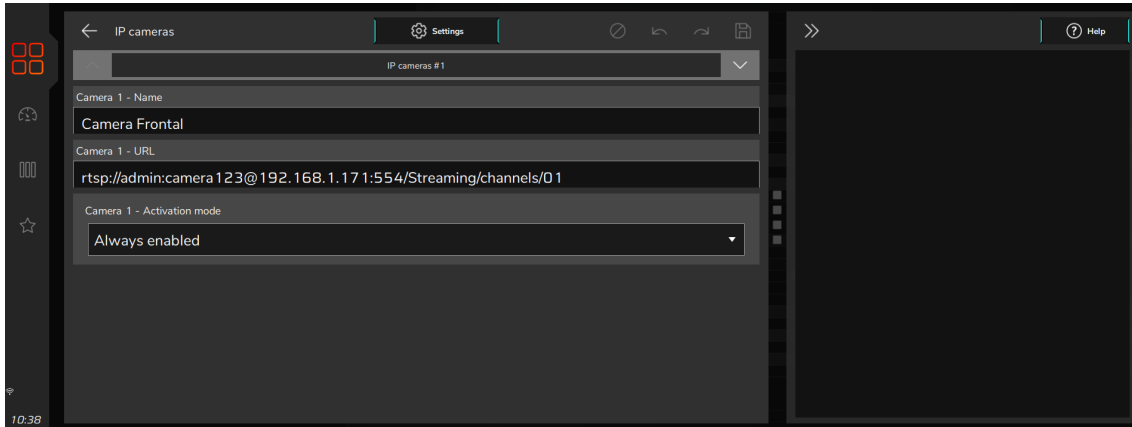

## 25.19 Analog camera

This function configures an analog camera. This camera must be connected to the FT700 M connector devices.

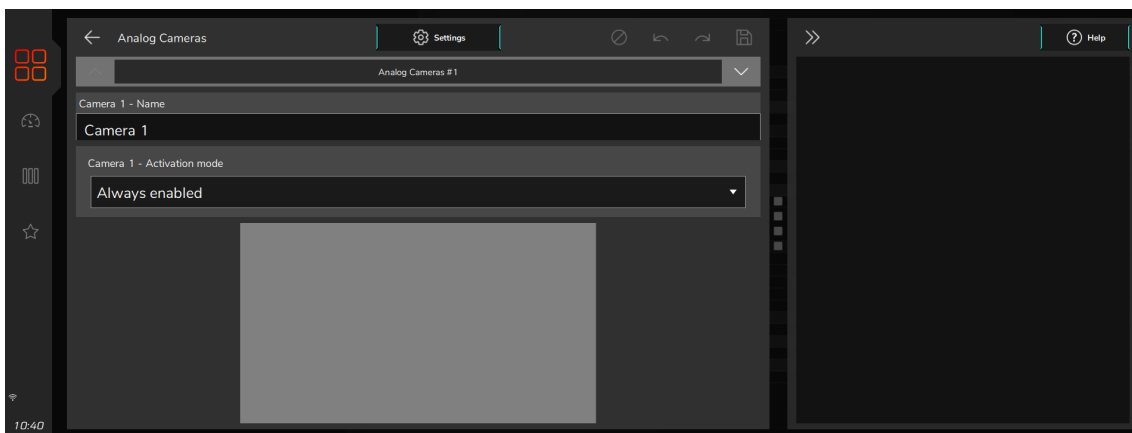

## 25.20 Advanced map settings

This function allows you to change the configuration mode of some functions. There are cases where the default values need to be adjusted, in which case it is necessary to change the settings to advanced mode.

Use this function only with the assistance of technical support.

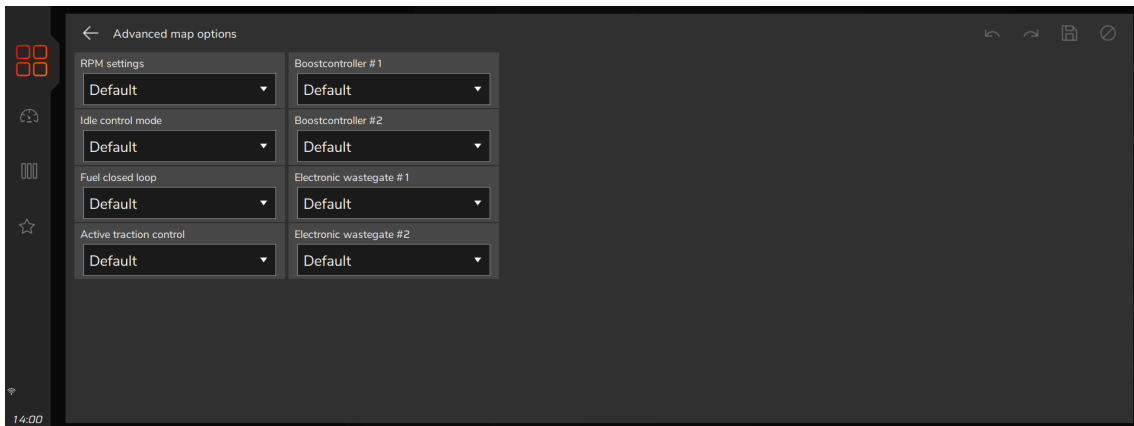

## 25.21 Yellow outputs

Configures the operating mode of the yellow outputs allowing flexibility in their operation.

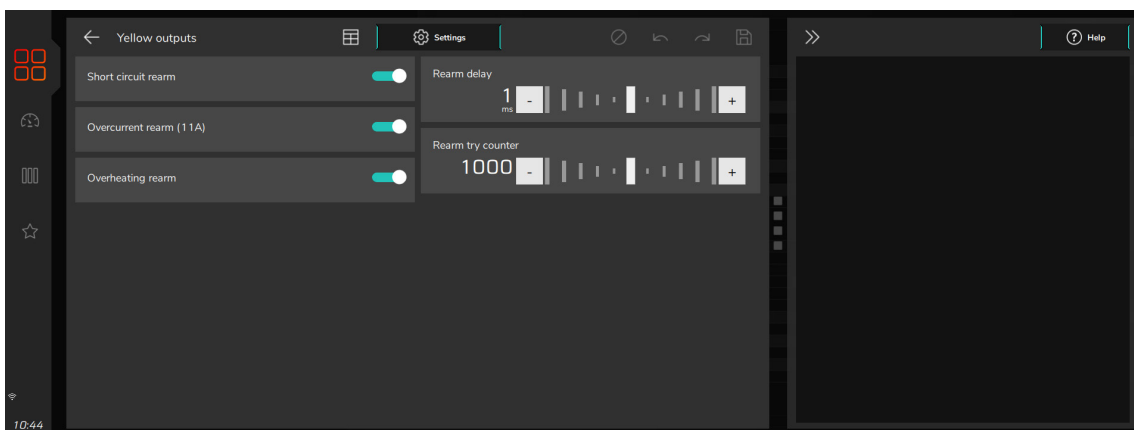
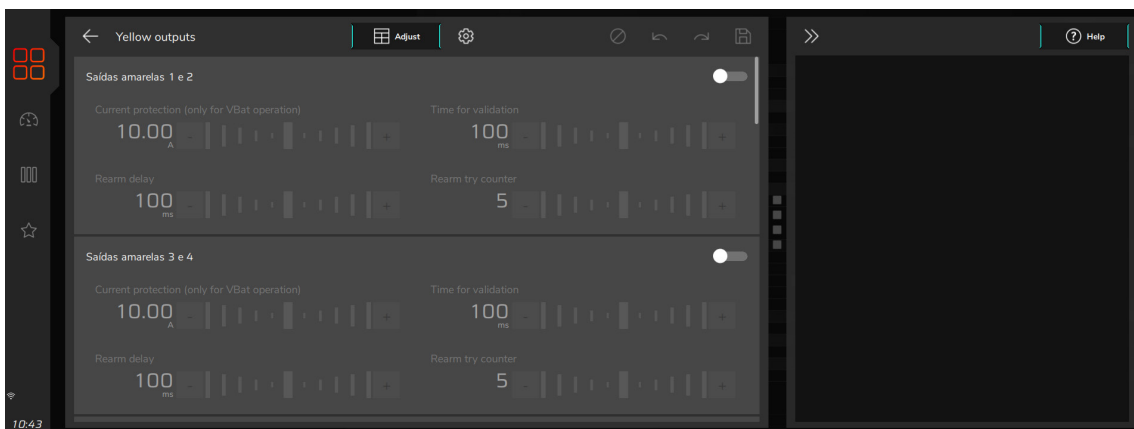

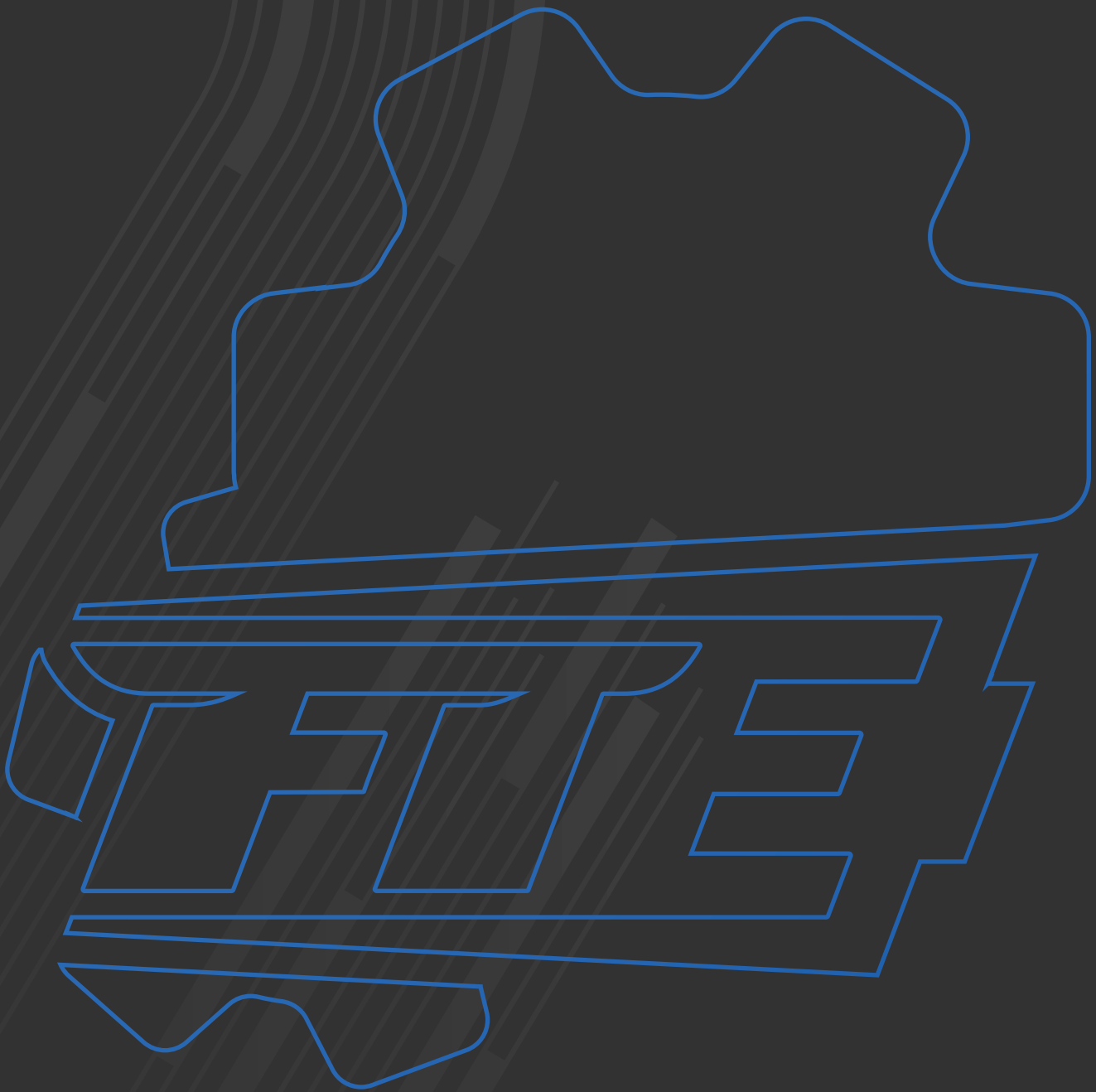

**EV**

Settings



## 26. EV Settings

This section is dedicated to controlling electric and hybrid vehicles.

The control and monitoring functions of the system for electrified vehicles will be explained.

### Important notes

- FuelTech VCU will always send a torque request to the electrification system regardless of which Power Train is installed on the vehicle.
- The 12V battery is required to power the vehicle's original systems.
- The VCU post-switch will be done by a white input, that is, the VCU will always be "on" in standby mode and monitoring the 12V battery charge level and the Battery Pack charging.
- In standby condition, the VCU screen can be turned off to save the 12V battery. FuelTech VCU will draw 0.06A per hour in this standby mode.
- All communication between the VCU and the control modules of the electrification system is done through the CAN protocol. For more information, contact our technical support.

### 26.1 Glossary

**BMS - Battery Management System:** responsible for monitoring the battery pack cells. Informs the VCU in real time various information such as: cell voltage, current, temperatures, status and faults, etc.

This equipment is only used when the battery pack is Li-Ion. For lead batteries the BMS is not required.

**OBC - On-Board Charge:** Battery pack charger. Connected together with the BMS to charge the battery pack when the vehicle is connected to a charging station.

**DC/DC Converter:** Responsible for charging the vehicle's 12V battery (the electric vehicle's alternator). This equipment keeps the 12V battery charged using the charge from the battery pack.

**PDU - Power Distribution Unit:** Power control unit for the battery pack. The system operates when the starter key is off or in an emergency, cutting the positive and negative of the battery pack.

**Frequency Inverter:** Responsible for effectively controlling the electric motor through torque and regeneration commands received from the VCU.

**SOC - State of Charge:** Informs the percentage of discharge and charge level of the battery pack.

**Creeping:** Function that works in conjunction with the brake pedal. When releasing the brake pedal, the vehicle will start to move without the need to press the accelerator.

**Power Train:** Pack of inverter and electric motor.

**DCL - Discharge current limit:** The discharge current limit of the battery pack.

**CCL - Charge current limit:** The battery pack charge current limit.

### 26.2 Powertrain

This function configures the type of Inverter/Motor and also the control mode including which outputs will be controlled for each system.

#### Inverter model

There are 5 configurable models available (WEG CVW300 and CVW500, Gtake KTZ34, Kelly KAC8080 and SME A-X144) when selecting a model, different configuration options are enabled.

**WEG CVW500 inverter:** For this model, it is necessary to define the power reduction strategy; the speed to activate the regeneration mode, the minimum pedal position, the maximum and nominal current and the clockwise and counter-clockwise torque.

**WEG CVW300 Inverter:** For this model, configure the minimum percentage of the pedal to allow torque, the maximum and nominal current of the motor and also the clockwise and counterclockwise torque.

**Gtake KTZ34 / Kelly KAC8080 / SME A-X144 Inverter:** For this model, configure the minimum percentage of the pedal to allow torque, the maximum and nominal current of the motor and also the clockwise and counterclockwise torque.

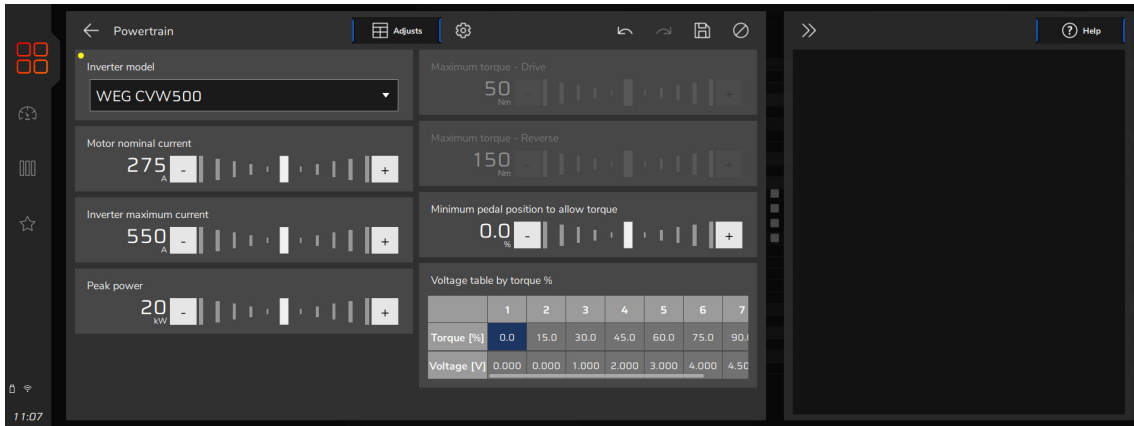

**PWM digital output by % Torque:** Some inverters have an analogue or PWM control input, it is possible to configure a PWM table by % of torque. In this case, it is necessary to define how the EV % of torque output is activated (0V inverted or 12V Normal), and adjust the frequency of this PWM.

**Power relay control:** Relay control activated by the VCU.

- **EV positive power relay output:** Output to the vehicle's positive power relay.
- **EV Negative Power Relay output:** Output for the vehicle's negative power relay.

### Powertrain Control

**Brake output:** Output responsible for activating the regeneration function. It is necessary to configure the “Brake Light” function in the “Other Functions/Signaling” section, so that the regeneration control is activated.

**Forward output:** Output responsible for activating the relay connected to the inverter input that allows the vehicle to move forward.

**Reverse output:** Output responsible for activating the relay connected to the inverter input that allows the vehicle to move backwards.

**Parking brake output:** Output responsible for activating the relay connected to the vehicle’s parking brake.

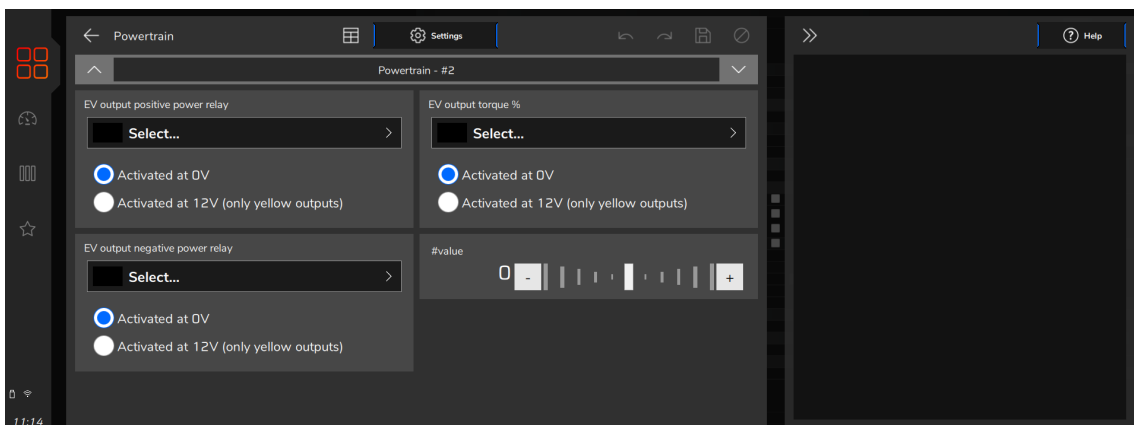
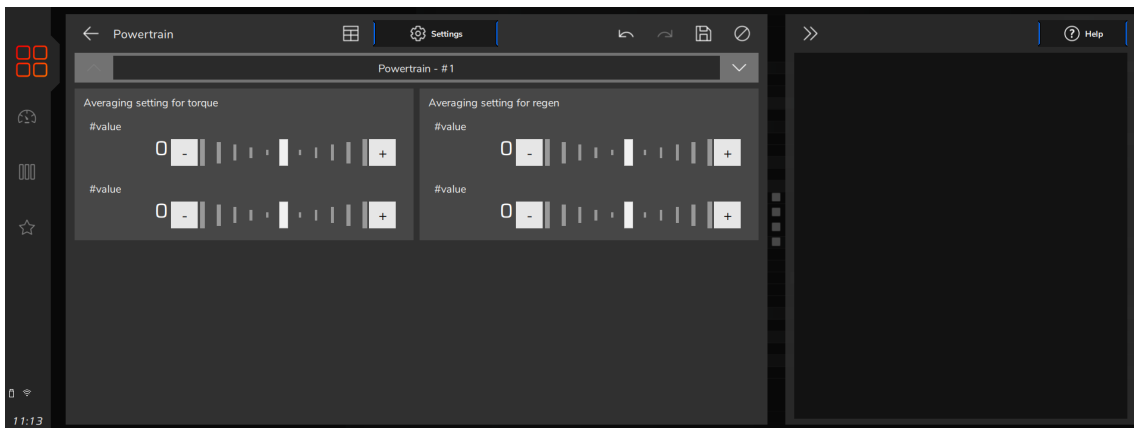

### 26.3 EV output configuration

This function is responsible for the operation mode of the car's EV system. The following outputs can be enabled, and whether they will be activated at 0V or 12V.

**EV Inverter ON/OFF output signal:** Output for initializing the vehicle's inverter.

**EV Enable all output signal:** Output for enabling the vehicle's inverter. Mainly used after pre-charging inverters.

**EV charge enable output signal:** Output for enabling the load that the inverter will release on the vehicle.

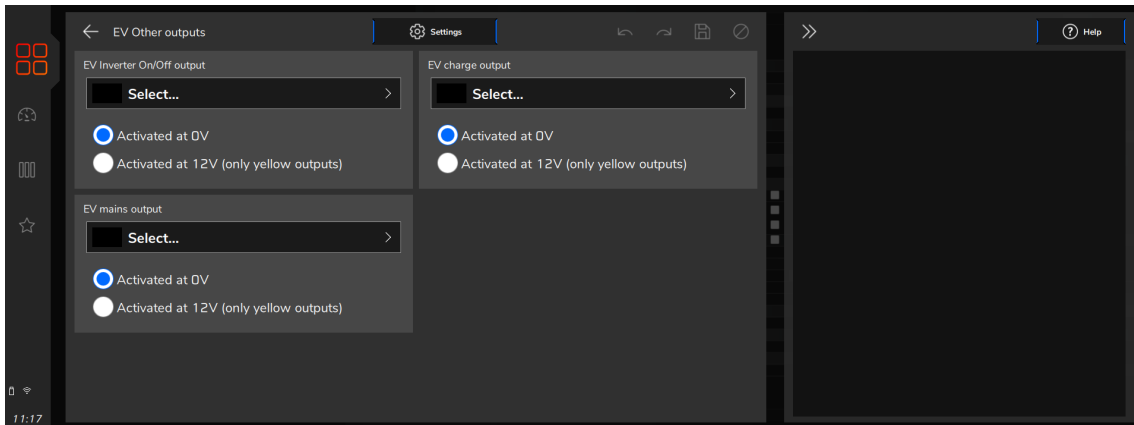

### 26.4 Battery

This function manages the charge of the battery pack. The parameters configured here will serve as the basis for controlling the battery pack charge. There are four BMS (charge controllers) options to choose from:

**Without BMS:** used when the battery pack is built with conventional lead cell batteries. It is necessary to adjust the DCL and CCL parameters. It is recommended to use a current sensor in the battery pack and connect it to a white “HV Battery Current” input on the VCU.

**ORION / LITHIUM and WEG:** for these BMSs it is necessary to configure the minimum and maximum SOC to allow torque and regeneration, in addition to configuring the detraction limit and speed to turn off these controls.

**Inverter pre-charge time:** this is the time the inverter takes to perform the pre-charge, during this configured time the VCU will not send torque requests to the inverter.

**Battery energy:** in this field it is necessary to inform the energy in kWh of the battery pack. This value will be used to calculate the efficiency metrics.

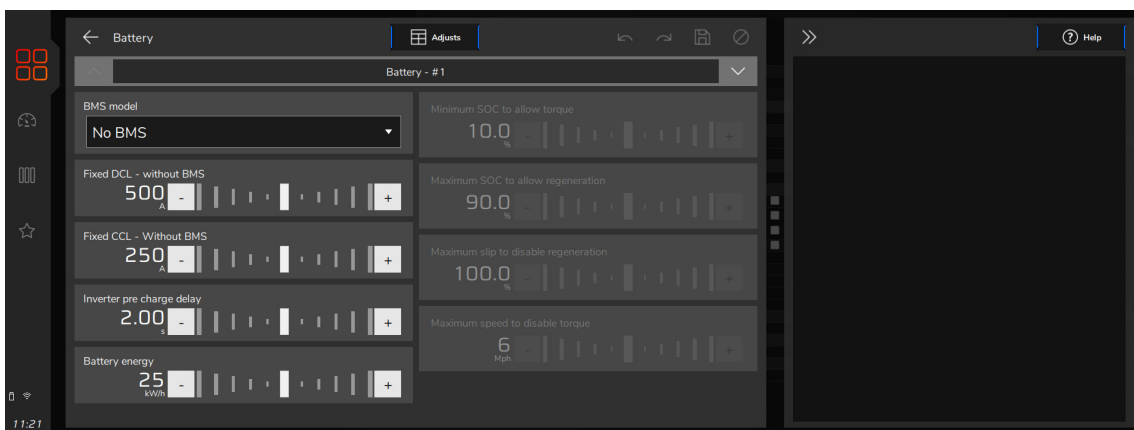

## Efficiency metrics

It is possible to activate information about autonomy and battery consumption as the vehicle travels. These values are updated every 100 meters driven by the vehicle.

**Last trip:** Calculation of how much power was used (W), and how much distance was traveled (km). This distance is counted after every 100 meters traveled until the moment it is turned off.

**Last charge:** Calculation of how much power was used (W), and how much distance was traveled (km). This distance is counted since the last time the vehicle was recharged.

**Total:** Metric accounting for the power used (W), and how much distance traveled (km). This distance is total until the metric is reset to zero.

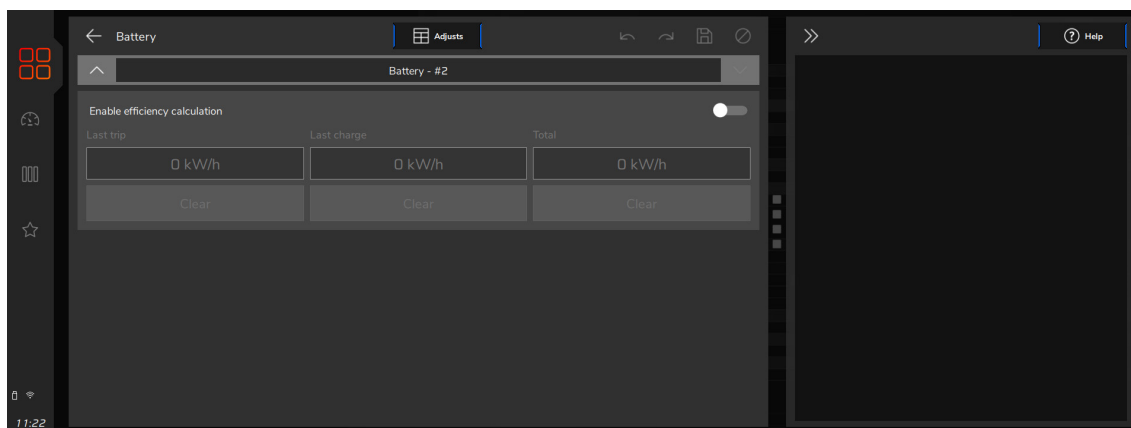

## 26.5 DCDC Converter

This function is responsible for communicating with the vehicle's DC/DC charger, and informs the essential parameters for operation

**Allow DC/DC with SOC above:** In this setting, create a charge limit so that the battery pack can start charging the vehicle's 12V battery.

**Use when charging & Use when vehicle started:** Allows you to release the 12V battery charge while the vehicle is running or plugged into the charging socket.

**Charge battery below and above:** Create limits in Volts for 12V battery charge.

**EV Output Signal Enabled DC/DC:** configures the output signal for activating the relay for DC/DC operation.

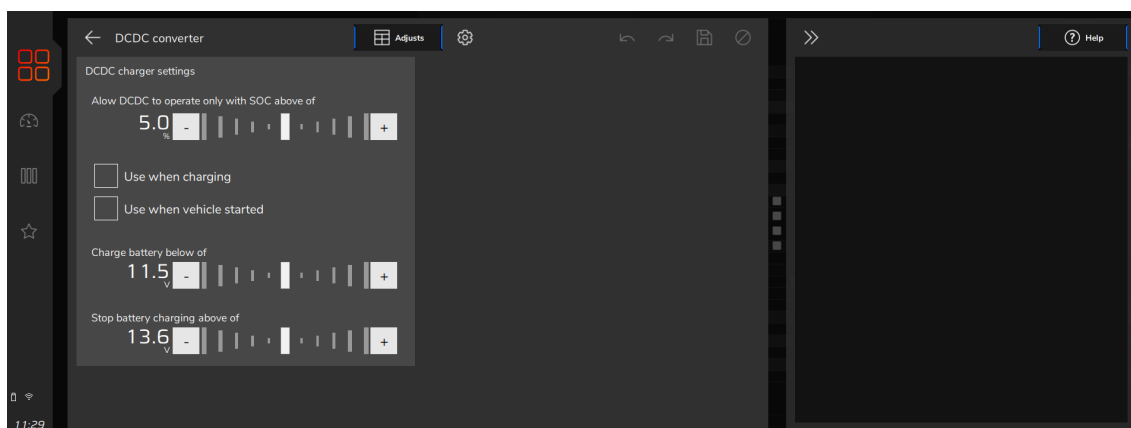

## 26.6 Driving assistances

This function contains general vehicle driving settings such as: Creeping, reverse gear limiter, vehicle direction control and GearController.

### Creeping

When activating this function, the vehicle will start to move as soon as the pressure on the brake pedal is being reduced by the driver. This function is very similar to a vehicle with an automatic transmission when the brake pedal is released.

Adjust the parameters so that the creeping function works as best serves the driver.

**Creeping target by:** defines whether the target will be based on vehicle speed or electric motor RPM.

**Maximum torque at which the control will saturate:** The percentage of torque at which the creeping function will deactivate.

**Initial ramp of creeping torque:** Creates a ramp from 0% to the value configured in “Maximum torque at which the control will saturate”.

There are two ways to control time and pressure:

- **By time:** When the brake is detected as inactive, the function will wait the configured time to reach the maximum torque value.
- **By brake pressure:** When releasing pressure on the brake pedal, an interpolation will be made between the brake detection points and the maximum torque target. “Brake Servo” must be configured in the “Other functions” menu.

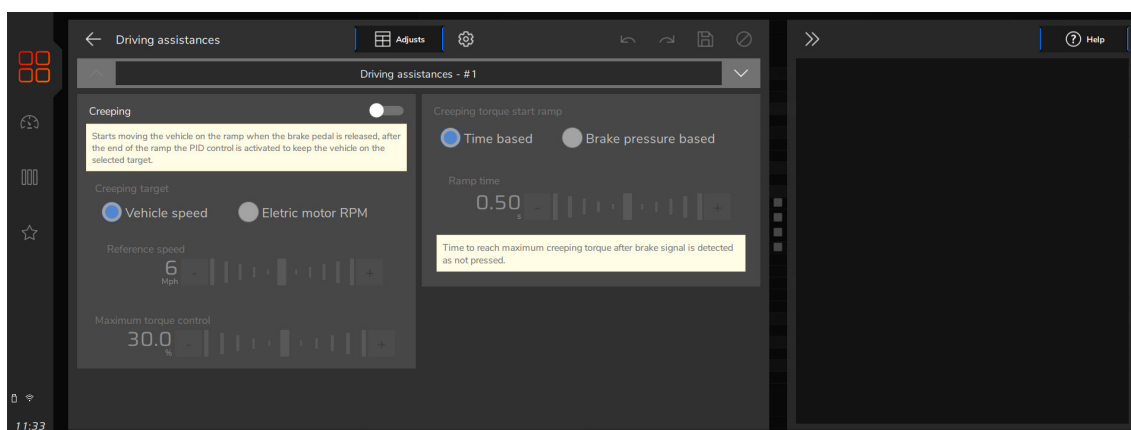

**Reverse Limiter:** Activates the reverse speed limit control. This control is very important as electric cars can reach the same speed in forward and reverse, it is mandatory to adjust these limits.

There are the same configurable parameters as the creeping function, minus the ramp.

**Forward / reverse mode:** For electric vehicles, direction reversal is performed using a button not only through the gearbox (when equipped), it is necessary to define the maximum speed at which the change of direction will be performed. It is possible to press the direction change button at any time, but it will only act when the speed is below the maximum configured speed.

**GearController EV:** Torque control for each gear change controlled by a button, when pressed, cuts engine torque electrically, in order to change gears without using the clutch. (Only for vehicles equipped with a gearbox).

**Advanced settings:** These settings act directly on the function's PID, in 99% of cases it is not necessary to adjust these parameters. If you are going to change any of these values, contact our technical support to seek guidance on how to proceed.

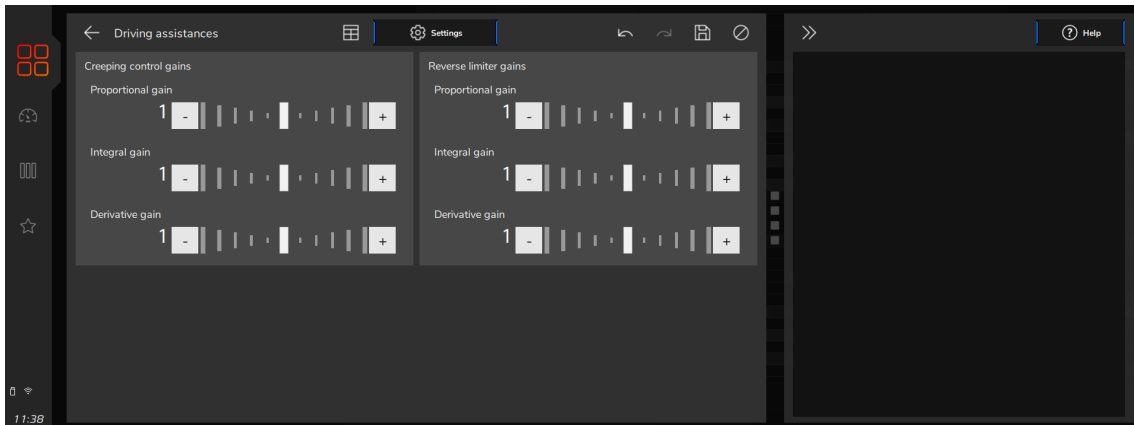
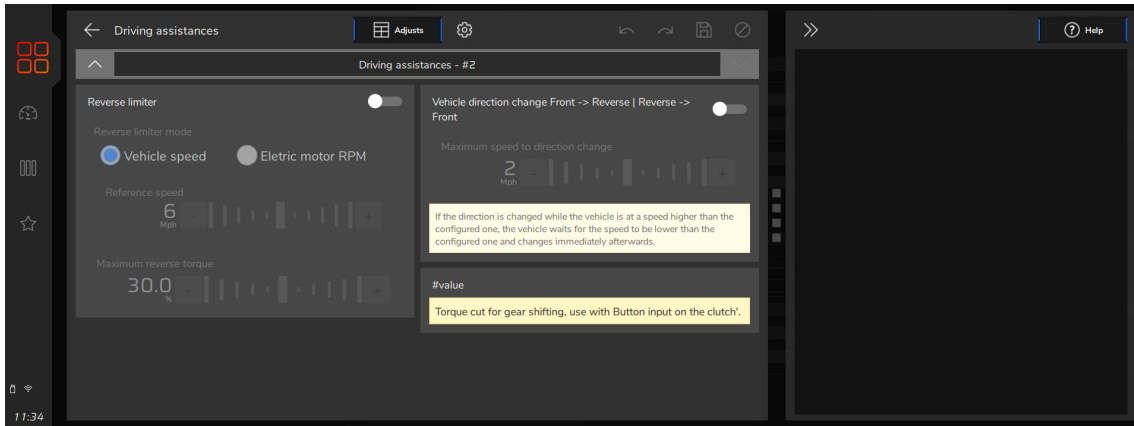

## 26.7 Charging Control

This function allows you to configure which On Board Charger will be used in the vehicle. Select the OBC Model and the VCU will be set with the parameters necessary for correct functioning of the charger.

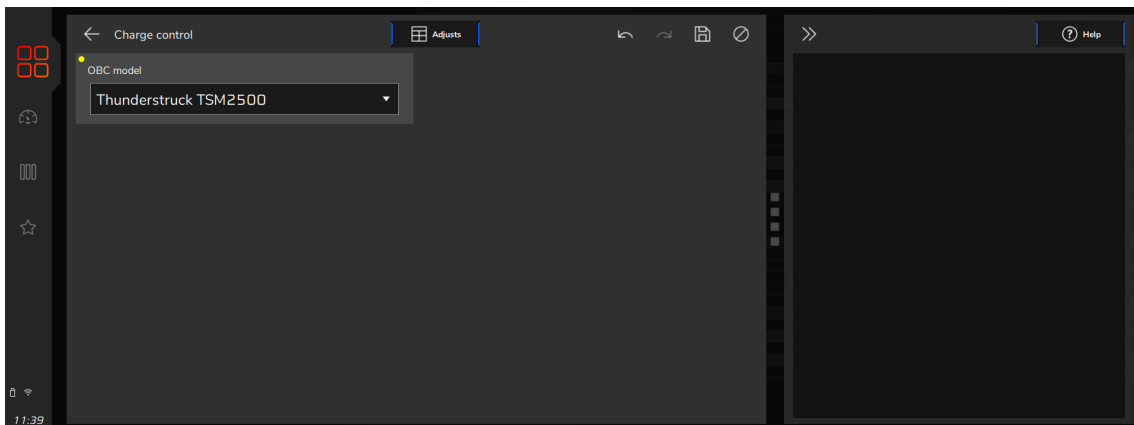

## 26.8 Torque and Regen

In this function it is possible to configure the torque and regeneration tables for different vehicle conditions. The percentages within each table will be multiplied between all tables to build the required values of torque and/or regeneration.

**Tables available for torque % by:** Pedal Position, RPM, Speed, Battery Voltage, Cell Voltage, Battery SOC, Inverter Temperature, Motor Temperature, Battery Temperature.

**Tables available for regeneration % by:** Brake Pressure, Pedal Position, Battery Voltage, Cell Voltage, Speed, Battery Temperature, Battery SOC, RPM, Motor Temperature, Inverter Temperature.

For example: In the pedal position table, the user informs the VCU that with 10% of TPS the torque request is 100% while in the torque by speed table it is informed that at 1km/h, the motor operates with a torque of 20%. When the user is pressing 100% of the acceleration pedal, but the vehicle is at 1km/h or less, only 20% of torque will be released to the engine, due to the multiplication of the tables. The same works for regeneration tables, if they are configured accordingly

**Moving average setting for torque and regen control Number of samples:** The number of samples to calculate the average torque and regen value. **Torque moving average period:** Adjusts the time between each sample capture for the average calculation. The recommended value is 20ms.

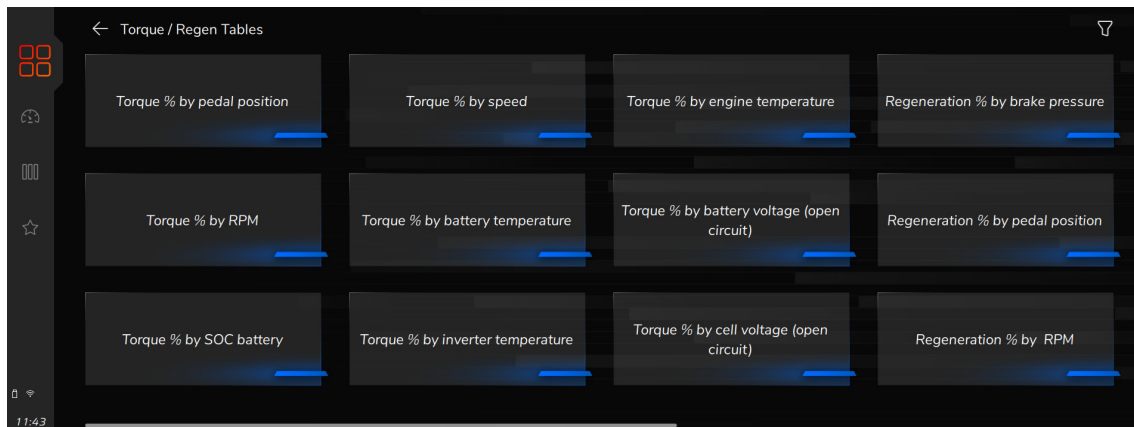

## 27. Custom function

This section allows you to create customized functions according to the project's needs. This function is only available in the VisionFT software for configuration.

This function is divided into three parts for configuration. To customizing the function, you must right-click to open the menu with all the configuration possibilities.

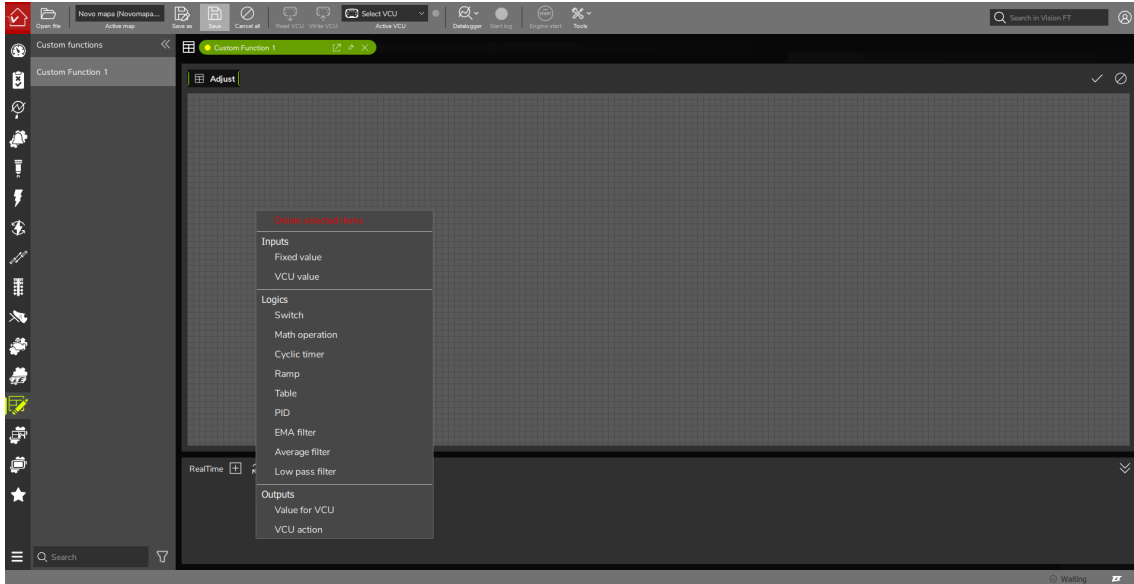

### Inputs

The first configuration refers to data input for customization.

- **Fixed Value:** defines a value for the function to be triggered.
- **VCU Value:** defines the value based on a sensor or parameter configured in the VCU

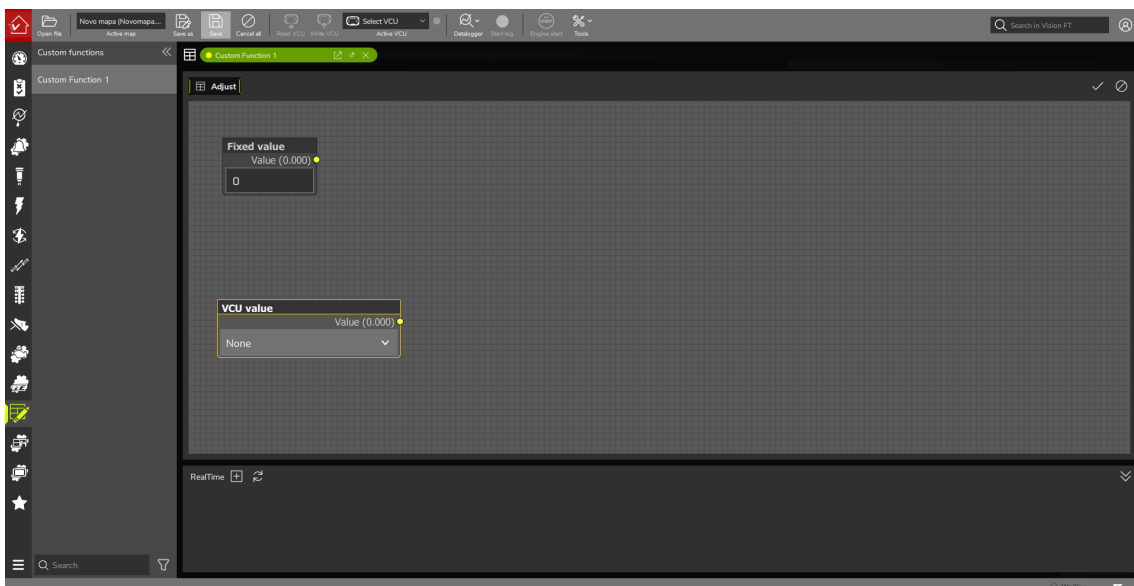

## Logics

Allows you to create a multitude of operations based on several parameters such as:

- **Switch:** creates an on/off logic for different modes (above, below, within or outside the range).
- **Math operation:** uses the input data to perform addition, subtraction, multiplication, division, minimum and maximum operations.
- **Cyclic timer:** sets a start and end time for the function.
- **Ramp:** creates a time ramp for the start or end of the function.
- **Table:** sets a table for the function.
- **PID:** creates a PID table.
- **Filters (EMA / averages / low pass):** allows you to create filters for each function.

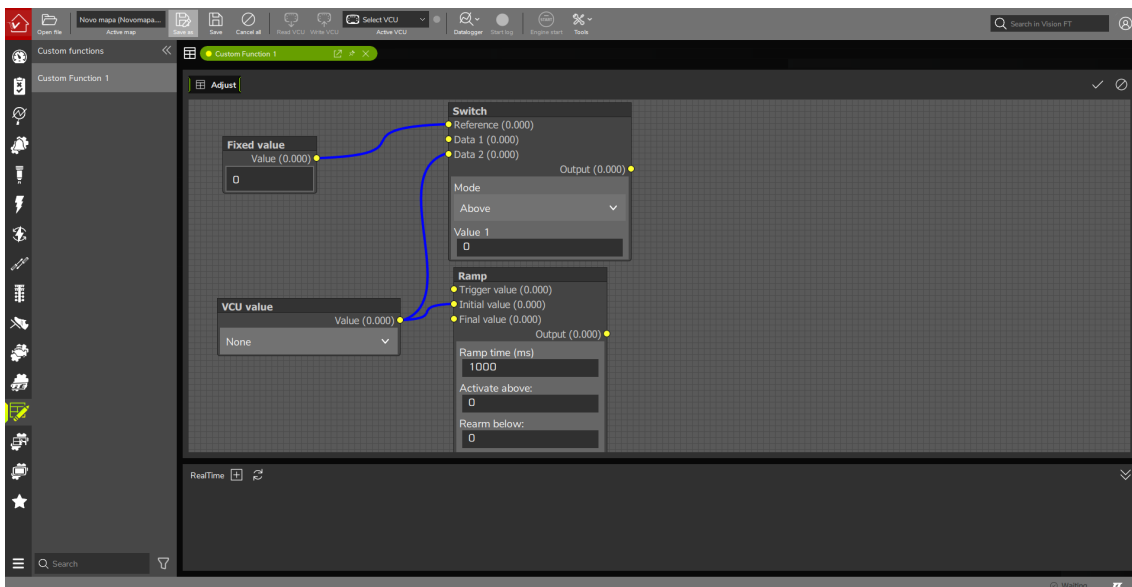

## Outputs

In this step, you configure the actions that will be executed by the VCU.

- **Value for VCU:** allows the VCU to act on the map according to the instructions programmed in the function.
- **VCU action:** uses the result of the function on the map automatically.

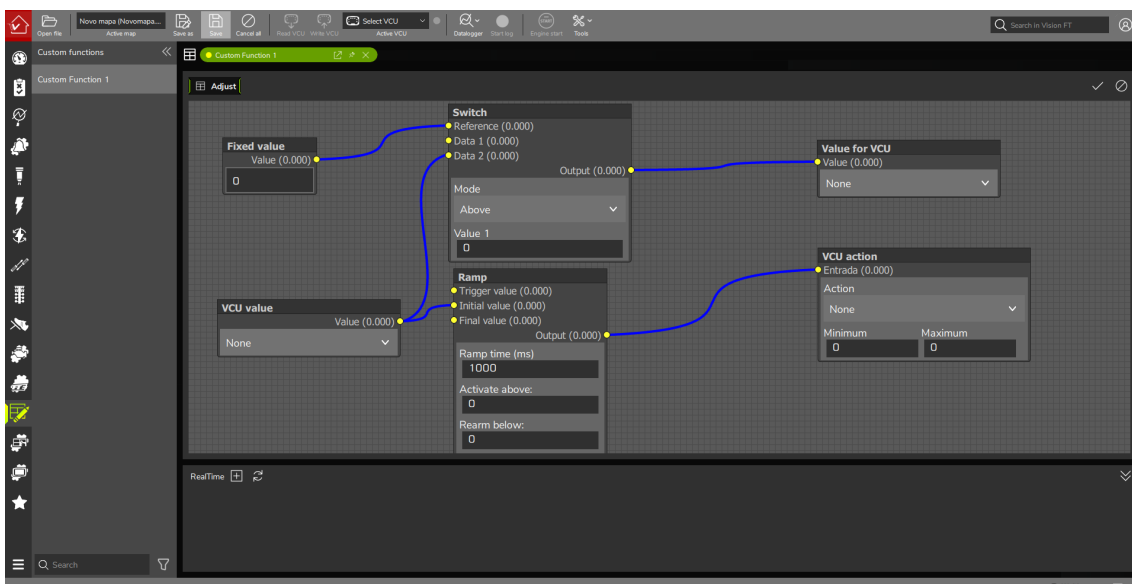

To remove a component, simply right-click on the block and select the first option "Remove selected items". Use the yellow dots to make the connection between the control blocks. Click on each point that you want to connect. It is possible to create more than one connection between the same data.

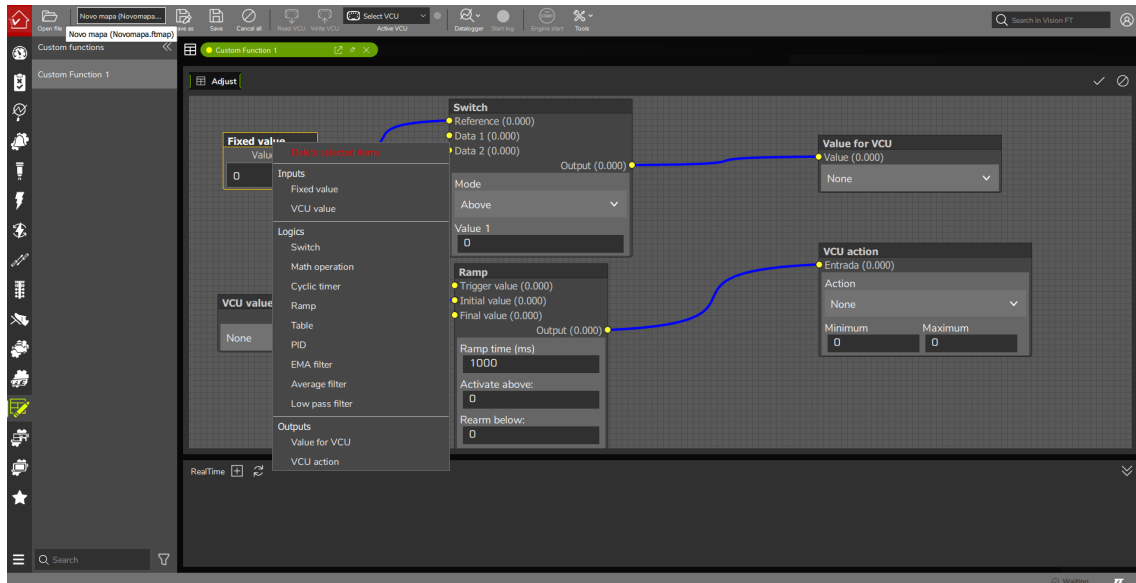



## USA

FuelTech USA,  
455 Wilbanks Dr.  
Ball Ground, GA, 30107, USA  
Phone: +1 678-493-3835  
[info@FuelTech.net](mailto:info@FuelTech.net)  
[www.FuelTech.net](http://www.FuelTech.net)

## BRASIL

FuelTech Ltda.  
Av. das Indústrias, 864, Bairro Anchieta  
CEP 90200-290, Porto Alegre, RS, Brasil  
CNPJ 05.704.744/0001-00  
Fone: +55 (51) 3019-0500  
[info@fueltech.com.br](mailto:info@fueltech.com.br)  
[www.FuelTech.com.br](http://www.FuelTech.com.br)

FOLLOW US



capa

## 28 - Overall Dimensions

FT700

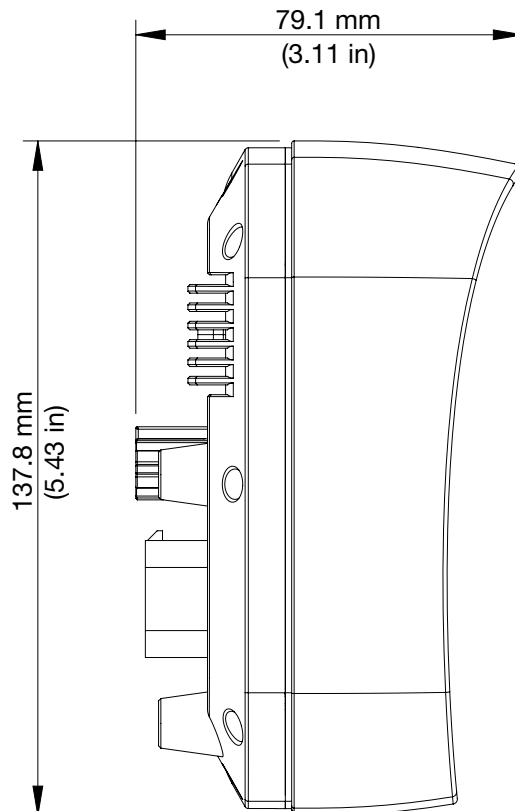
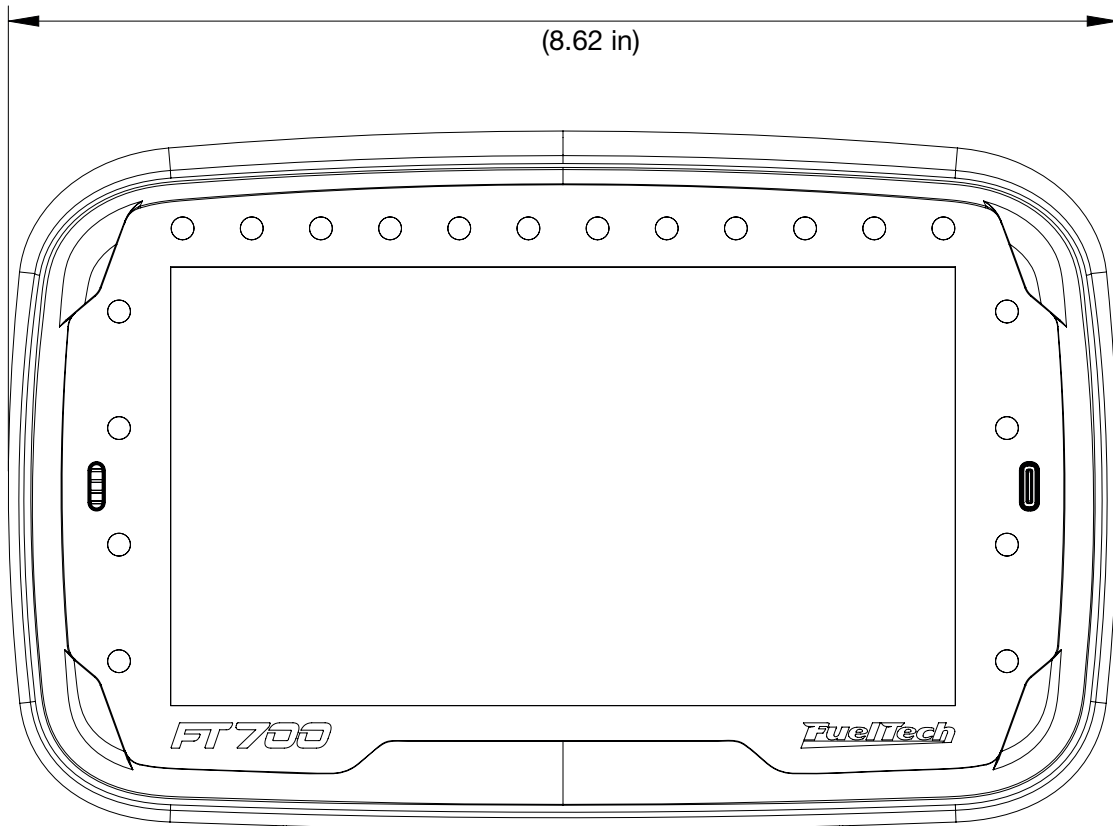

FT700 Plus

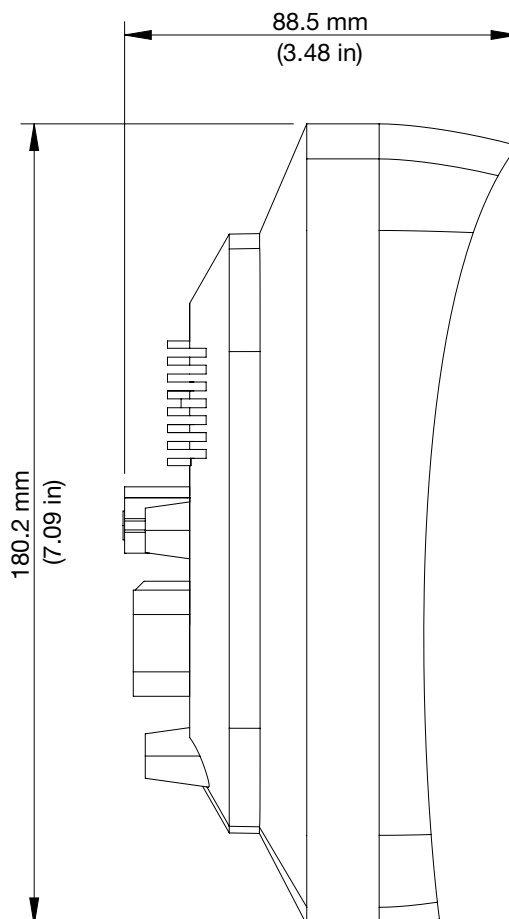
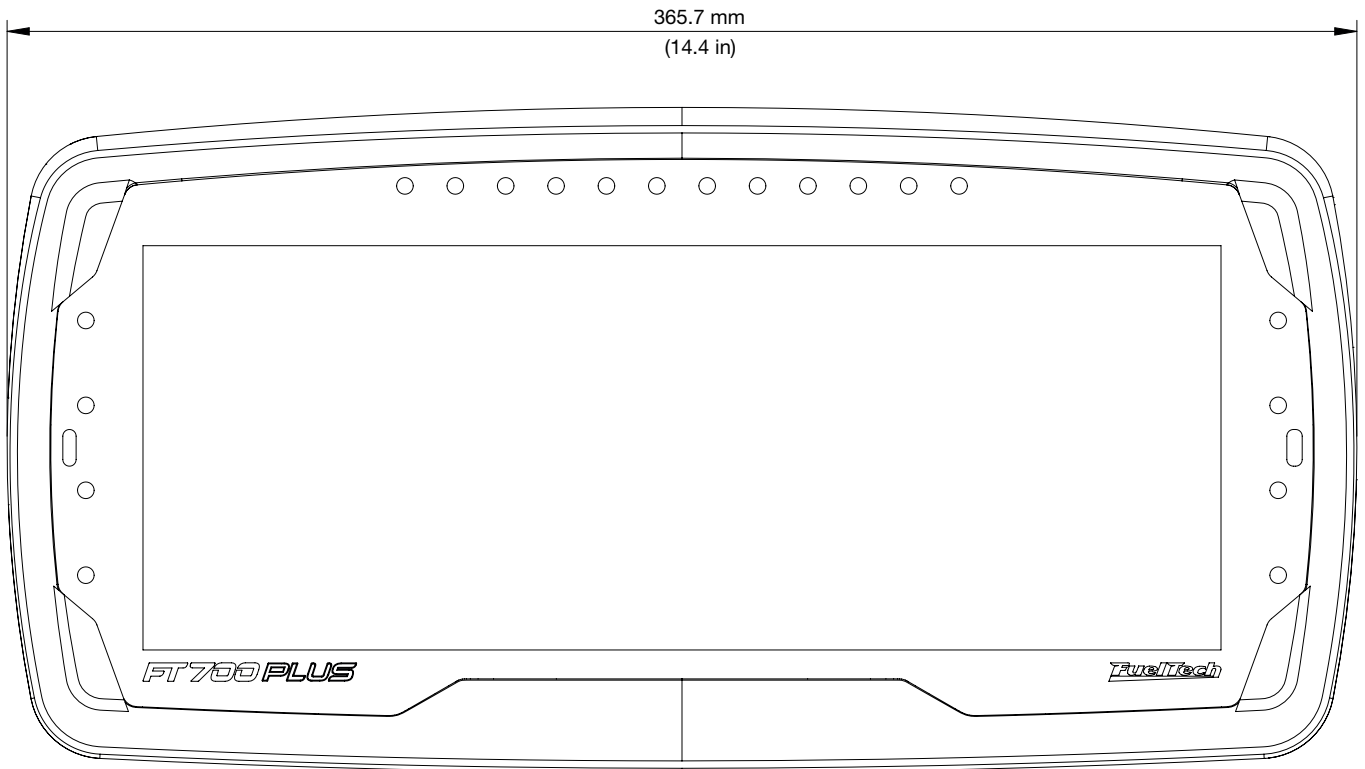

## 29 - Mounting Template

The mounting template for the FT700 and FT700 Plus is shown below. The template must be printed at 1:1 scale to ensure the correct installation dimensions.

